

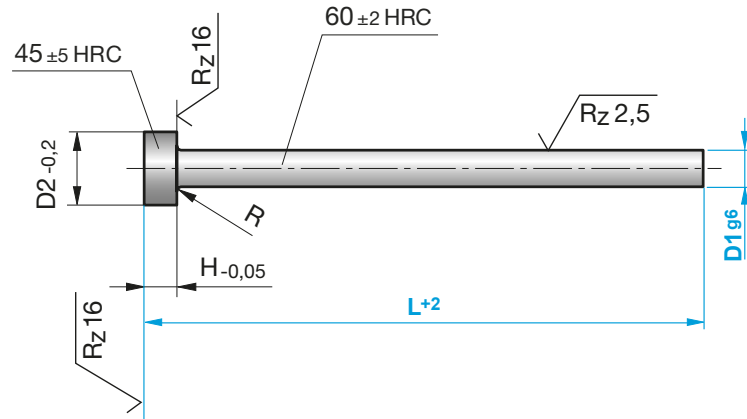

Z98
Ejector pin



Mat.:
~1.2516
Norm:
DIN ISO 6751
60+2 HRC

D1	L	D2	H	R	Order No.
0.8	40	3	1.5	0.2	Z98-0.8-40
0.8	63	3	1.5	0.2	Z98-0.8-63
0.8	80	3	1.5	0.2	Z98-0.8-80
0.8	100	3	1.5	0.2	Z98-0.8-100
0.8	125	3	1.5	0.2	Z98-0.8-125
0.8	160	3	1.5	0.2	Z98-0.8-160
0.9	40	3	1.5	0.2	Z98-0.9-40
0.9	63	3	1.5	0.2	Z98-0.9-63
0.9	80	3	1.5	0.2	Z98-0.9-80
0.9	100	3	1.5	0.2	Z98-0.9-100
0.9	125	3	1.5	0.2	Z98-0.9-125
1	40	3	1.5	0.2	Z98-1-40
1	63	3	1.5	0.2	Z98-1-63
1	80	3	1.5	0.2	Z98-1-80
1	100	3	1.5	0.2	Z98-1-100
1	125	3	1.5	0.2	Z98-1-125
1	160	3	1.5	0.2	Z98-1-160
1	200	3	1.5	0.2	Z98-1-200
1	250	3	1.5	0.2	Z98-1-250
1.1	40	3	1.5	0.2	Z98-1.1-40
1.1	63	3	1.5	0.2	Z98-1.1-63
1.1	80	3	1.5	0.2	Z98-1.1-80
1.1	100	3	1.5	0.2	Z98-1.1-100
1.1	125	3	1.5	0.2	Z98-1.1-125
1.1	160	3	1.5	0.2	Z98-1.1-160
1.1	200	3	1.5	0.2	Z98-1.1-200
1.1	250	3	1.5	0.2	Z98-1.1-250
1.2	40	3	1.5	0.2	Z98-1.2-40
1.2	63	3	1.5	0.2	Z98-1.2-63
1.2	80	3	1.5	0.2	Z98-1.2-80
1.2	100	3	1.5	0.2	Z98-1.2-100
1.2	125	3	1.5	0.2	Z98-1.2-125
1.2	160	3	1.5	0.2	Z98-1.2-160
1.2	200	3	1.5	0.2	Z98-1.2-200
1.2	250	3	1.5	0.2	Z98-1.2-250
1.2	315	3	1.5	0.2	Z98-1.2-315

D1	L	D2	H	R	Order No.
1.3	40	3	1.5	0.2	Z98-1.3-40
1.3	63	3	1.5	0.2	Z98-1.3-63
1.3	80	3	1.5	0.2	Z98-1.3-80
1.3	100	3	1.5	0.2	Z98-1.3-100
1.3	125	3	1.5	0.2	Z98-1.3-125
1.3	160	3	1.5	0.2	Z98-1.3-160
1.3	200	3	1.5	0.2	Z98-1.3-200
1.3	250	3	1.5	0.2	Z98-1.3-250
1.4	40	3	1.5	0.2	Z98-1.4-40
1.4	63	3	1.5	0.2	Z98-1.4-63
1.4	80	3	1.5	0.2	Z98-1.4-80
1.4	100	3	1.5	0.2	Z98-1.4-100
1.4	125	3	1.5	0.2	Z98-1.4-125
1.4	160	3	1.5	0.2	Z98-1.4-160
1.4	200	3	1.5	0.2	Z98-1.4-200
1.4	250	3	1.5	0.2	Z98-1.4-250
1.5	40	3	1.5	0.2	Z98-1.5-40
1.5	63	3	1.5	0.2	Z98-1.5-63
1.5	80	3	1.5	0.2	Z98-1.5-80
1.5	100	3	1.5	0.2	Z98-1.5-100
1.5	125	3	1.5	0.2	Z98-1.5-125
1.5	160	3	1.5	0.2	Z98-1.5-160
1.5	200	3	1.5	0.2	Z98-1.5-200
1.5	250	3	1.5	0.2	Z98-1.5-250
1.5	315	3	1.5	0.2	Z98-1.5-315
1.5	400	3	1.5	0.2	Z98-1.5-400
1.6	40	3	1.5	0.2	Z98-1.6-40
1.6	63	3	1.5	0.2	Z98-1.6-63
1.6	80	3	1.5	0.2	Z98-1.6-80
1.6	100	3	1.5	0.2	Z98-1.6-100
1.6	125	3	1.5	0.2	Z98-1.6-125
1.6	160	3	1.5	0.2	Z98-1.6-160
1.6	200	3	1.5	0.2	Z98-1.6-200
1.6	250	3	1.5	0.2	Z98-1.6-250
1.6	400	3	1.5	0.2	Z98-1.6-400
1.7	40	3	1.5	0.2	Z98-1.7-40



Z98

Ejector pin



D1	L	D2	H	R	Order No.	D1	L	D2	H	R	Order No.
1.7	63	3	1.5	0.2	Z98-1.7-63	2.3	250	4	2.0	0.2	Z98-2.3-250
1.7	80	3	1.5	0.2	Z98-1.7-80	2.3	315	4	2.0	0.2	Z98-2.3-315
1.7	100	3	1.5	0.2	Z98-1.7-100	2.4	100	5	2.0	0.3	Z98-2.4-100
1.7	125	3	1.5	0.2	Z98-1.7-125	2.4	125	5	2.0	0.3	Z98-2.4-125
1.7	160	3	1.5	0.2	Z98-1.7-160	2.4	160	5	2.0	0.3	Z98-2.4-160
1.7	200	3	1.5	0.2	Z98-1.7-200	2.4	200	5	2.0	0.3	Z98-2.4-200
1.7	250	3	1.5	0.2	Z98-1.7-250	2.4	250	5	2.0	0.3	Z98-2.4-250
1.8	40	3	1.5	0.2	Z98-1.8-40	2.4	315	5	2.0	0.3	Z98-2.4-315
1.8	63	3	1.5	0.2	Z98-1.8-63	2.5	40	5	2.0	0.3	Z98-2.5-40
1.8	80	3	1.5	0.2	Z98-1.8-80	2.5	63	5	2.0	0.3	Z98-2.5-63
1.8	100	3	1.5	0.2	Z98-1.8-100	2.5	80	5	2.0	0.3	Z98-2.5-80
1.8	125	3	1.5	0.2	Z98-1.8-125	2.5	100	5	2.0	0.3	Z98-2.5-100
1.8	160	3	1.5	0.2	Z98-1.8-160	2.5	125	5	2.0	0.3	Z98-2.5-125
1.8	200	3	1.5	0.2	Z98-1.8-200	2.5	160	5	2.0	0.3	Z98-2.5-160
1.8	250	3	1.5	0.2	Z98-1.8-250	2.5	200	5	2.0	0.3	Z98-2.5-200
1.8	400	3	1.5	0.2	Z98-1.8-400	2.5	250	5	2.0	0.3	Z98-2.5-250
1.9	40	3	1.5	0.2	Z98-1.9-40	2.5	315	5	2.0	0.3	Z98-2.5-315
1.9	63	3	1.5	0.2	Z98-1.9-63	2.5	400	5	2.0	0.3	Z98-2.5-400
1.9	80	3	1.5	0.2	Z98-1.9-80	2.5	500	5	2.0	0.3	Z98-2.5-500
1.9	100	3	1.5	0.2	Z98-1.9-100	2.5	800	5	2.0	0.3	Z98-2.5-800
1.9	125	3	1.5	0.2	Z98-1.9-125	2.6	100	5	2.0	0.3	Z98-2.6-100
1.9	160	3	1.5	0.2	Z98-1.9-160	2.6	125	5	2.0	0.3	Z98-2.6-125
1.9	200	3	1.5	0.2	Z98-1.9-200	2.6	160	5	2.0	0.3	Z98-2.6-160
1.9	250	3	1.5	0.2	Z98-1.9-250	2.6	200	5	2.0	0.3	Z98-2.6-200
2	40	4	2.0	0.2	Z98-2-40	2.6	250	5	2.0	0.3	Z98-2.6-250
2	63	4	2.0	0.2	Z98-2-63	2.6	315	5	2.0	0.3	Z98-2.6-315
2	80	4	2.0	0.2	Z98-2-80	2.7	80	5	2.0	0.3	Z98-2.7-80
2	100	4	2.0	0.2	Z98-2-100	2.7	100	5	2.0	0.3	Z98-2.7-100
2	125	4	2.0	0.2	Z98-2-125	2.7	125	5	2.0	0.3	Z98-2.7-125
2	160	4	2.0	0.2	Z98-2-160	2.7	160	5	2.0	0.3	Z98-2.7-160
2	200	4	2.0	0.2	Z98-2-200	2.7	200	5	2.0	0.3	Z98-2.7-200
2	250	4	2.0	0.2	Z98-2-250	2.7	250	5	2.0	0.3	Z98-2.7-250
2	315	4	2.0	0.2	Z98-2-315	2.7	315	5	2.0	0.3	Z98-2.7-315
2	400	4	2.0	0.2	Z98-2-400	2.7	400	5	2.0	0.3	Z98-2.7-400
2	500	4	2.0	0.2	Z98-2-500	2.7	500	5	2.0	0.3	Z98-2.7-500
2.1	80	4	2.0	0.2	Z98-2.1-80	2.7	800	5	2.0	0.3	Z98-2.7-800
2.1	100	4	2.0	0.2	Z98-2.1-100	2.8	100	5	2.0	0.3	Z98-2.8-100
2.1	125	4	2.0	0.2	Z98-2.1-125	2.8	125	5	2.0	0.3	Z98-2.8-125
2.1	160	4	2.0	0.2	Z98-2.1-160	2.8	160	5	2.0	0.3	Z98-2.8-160
2.1	200	4	2.0	0.2	Z98-2.1-200	2.8	200	5	2.0	0.3	Z98-2.8-200
2.1	250	4	2.0	0.2	Z98-2.1-250	2.8	315	5	2.0	0.3	Z98-2.8-315
2.1	315	4	2.0	0.2	Z98-2.1-315	2.9	100	6	3.0	0.3	Z98-2.9-100
2.2	80	4	2.0	0.2	Z98-2.2-80	2.9	125	6	3.0	0.3	Z98-2.9-125
2.2	100	4	2.0	0.2	Z98-2.2-100	2.9	160	6	3.0	0.3	Z98-2.9-160
2.2	125	4	2.0	0.2	Z98-2.2-125	2.9	200	6	3.0	0.3	Z98-2.9-200
2.2	160	4	2.0	0.2	Z98-2.2-160	2.9	315	6	3.0	0.3	Z98-2.9-315
2.2	200	4	2.0	0.2	Z98-2.2-200	3	40	6	3.0	0.3	Z98-3-40
2.2	250	4	2.0	0.2	Z98-2.2-250	3	63	6	3.0	0.3	Z98-3-63
2.2	315	4	2.0	0.2	Z98-2.2-315	3	80	6	3.0	0.3	Z98-3-80
2.2	400	4	2.0	0.2	Z98-2.2-400	3	100	6	3.0	0.3	Z98-3-100
2.2	500	4	2.0	0.2	Z98-2.2-500	3	125	6	3.0	0.3	Z98-3-125
2.3	80	4	2.0	0.2	Z98-2.3-80	3	160	6	3.0	0.3	Z98-3-160
2.3	100	4	2.0	0.2	Z98-2.3-100	3	200	6	3.0	0.3	Z98-3-200
2.3	125	4	2.0	0.2	Z98-2.3-125	3	250	6	3.0	0.3	Z98-3-250
2.3	160	4	2.0	0.2	Z98-2.3-160	3	315	6	3.0	0.3	Z98-3-315
2.3	200	4	2.0	0.2	Z98-2.3-200	3	400	6	3.0	0.3	Z98-3-400

Z98
Ejector pin

6

D1	L	D2	H	R	Order No.	D1	L	D2	H	R	Order No.
3	500	6	3.0	0.3	Z98-3-500	3.8	125	7	3.0	0.3	Z98-3.8-125
3	630	6	3.0	0.3	Z98-3-630	3.8	160	7	3.0	0.3	Z98-3.8-160
3	800	6	3.0	0.3	Z98-3-800	3.8	200	7	3.0	0.3	Z98-3.8-200
3	1000	6	3.0	0.3	Z98-3-1000	3.8	315	7	3.0	0.3	Z98-3.8-315
3.1	100	6	3.0	0.3	Z98-3.1-100	3.9	100	7	3.0	0.3	Z98-3.9-100
3.1	125	6	3.0	0.3	Z98-3.1-125	3.9	125	7	3.0	0.3	Z98-3.9-125
3.1	160	6	3.0	0.3	Z98-3.1-160	3.9	160	7	3.0	0.3	Z98-3.9-160
3.1	200	6	3.0	0.3	Z98-3.1-200	3.9	200	7	3.0	0.3	Z98-3.9-200
3.1	250	6	3.0	0.3	Z98-3.1-250	3.9	250	7	3.0	0.3	Z98-3.9-250
3.1	315	6	3.0	0.3	Z98-3.1-315	3.9	400	7	3.0	0.3	Z98-3.9-400
3.1	400	6	3.0	0.3	Z98-3.1-400	4	40	8	3.0	0.3	Z98-4-40
3.2	80	6	3.0	0.3	Z98-3.2-80	4	63	8	3.0	0.3	Z98-4-63
3.2	100	6	3.0	0.3	Z98-3.2-100	4	80	8	3.0	0.3	Z98-4-80
3.2	125	6	3.0	0.3	Z98-3.2-125	4	100	8	3.0	0.3	Z98-4-100
3.2	160	6	3.0	0.3	Z98-3.2-160	4	125	8	3.0	0.3	Z98-4-125
3.2	200	6	3.0	0.3	Z98-3.2-200	4	160	8	3.0	0.3	Z98-4-160
3.2	250	6	3.0	0.3	Z98-3.2-250	4	200	8	3.0	0.3	Z98-4-200
3.2	315	6	3.0	0.3	Z98-3.2-315	4	250	8	3.0	0.3	Z98-4-250
3.2	400	6	3.0	0.3	Z98-3.2-400	4	315	8	3.0	0.3	Z98-4-315
3.2	500	6	3.0	0.3	Z98-3.2-500	4	400	8	3.0	0.3	Z98-4-400
3.2	800	6	3.0	0.3	Z98-3.2-800	4	630	8	3.0	0.3	Z98-4-630
3.3	100	6	3.0	0.3	Z98-3.3-100	4	800	8	3.0	0.3	Z98-4-800
3.3	125	6	3.0	0.3	Z98-3.3-125	4	1000	8	3.0	0.3	Z98-4-1000
3.3	160	6	3.0	0.3	Z98-3.3-160	4.1	125	8	3.0	0.3	Z98-4.1-125
3.3	200	6	3.0	0.3	Z98-3.3-200	4.1	160	8	3.0	0.3	Z98-4.1-160
3.3	400	6	3.0	0.3	Z98-3.3-400	4.1	200	8	3.0	0.3	Z98-4.1-200
3.4	100	6	3.0	0.3	Z98-3.4-100	4.1	250	8	3.0	0.3	Z98-4.1-250
3.4	125	6	3.0	0.3	Z98-3.4-125	4.1	315	8	3.0	0.3	Z98-4.1-315
3.4	160	6	3.0	0.3	Z98-3.4-160	4.1	400	8	3.0	0.3	Z98-4.1-400
3.4	200	6	3.0	0.3	Z98-3.4-200	4.1	500	8	3.0	0.3	Z98-4.1-500
3.4	315	6	3.0	0.3	Z98-3.4-315	4.2	80	8	3.0	0.3	Z98-4.2-80
3.4	400	6	3.0	0.3	Z98-3.4-400	4.2	100	8	3.0	0.3	Z98-4.2-100
3.5	80	7	3.0	0.3	Z98-3.5-80	4.2	125	8	3.0	0.3	Z98-4.2-125
3.5	100	7	3.0	0.3	Z98-3.5-100	4.2	160	8	3.0	0.3	Z98-4.2-160
3.5	125	7	3.0	0.3	Z98-3.5-125	4.2	200	8	3.0	0.3	Z98-4.2-200
3.5	160	7	3.0	0.3	Z98-3.5-160	4.2	250	8	3.0	0.3	Z98-4.2-250
3.5	200	7	3.0	0.3	Z98-3.5-200	4.2	315	8	3.0	0.3	Z98-4.2-315
3.5	250	7	3.0	0.3	Z98-3.5-250	4.2	400	8	3.0	0.3	Z98-4.2-400
3.5	315	7	3.0	0.3	Z98-3.5-315	4.2	500	8	3.0	0.3	Z98-4.2-500
3.5	400	7	3.0	0.3	Z98-3.5-400	4.2	800	8	3.0	0.3	Z98-4.2-800
3.5	500	7	3.0	0.3	Z98-3.5-500	4.2	1000	8	3.0	0.3	Z98-4.2-1000
3.5	630	7	3.0	0.3	Z98-3.5-630	4.2	1250	8	3.0	0.3	Z98-4.2-1250
3.6	100	7	3.0	0.3	Z98-3.6-100	4.3	100	8	3.0	0.3	Z98-4.3-100
3.6	125	7	3.0	0.3	Z98-3.6-125	4.3	125	8	3.0	0.3	Z98-4.3-125
3.6	160	7	3.0	0.3	Z98-3.6-160	4.3	160	8	3.0	0.3	Z98-4.3-160
3.6	200	7	3.0	0.3	Z98-3.6-200	4.3	200	8	3.0	0.3	Z98-4.3-200
3.6	250	7	3.0	0.3	Z98-3.6-250	4.3	400	8	3.0	0.3	Z98-4.3-400
3.6	400	7	3.0	0.3	Z98-3.6-400	4.4	100	8	3.0	0.3	Z98-4.4-100
3.7	100	7	3.0	0.3	Z98-3.7-100	4.4	125	8	3.0	0.3	Z98-4.4-125
3.7	125	7	3.0	0.3	Z98-3.7-125	4.4	160	8	3.0	0.3	Z98-4.4-160
3.7	160	7	3.0	0.3	Z98-3.7-160	4.4	200	8	3.0	0.3	Z98-4.4-200
3.7	200	7	3.0	0.3	Z98-3.7-200	4.4	400	8	3.0	0.3	Z98-4.4-400
3.7	250	7	3.0	0.3	Z98-3.7-250	4.5	80	8	3.0	0.3	Z98-4.5-80
3.7	315	7	3.0	0.3	Z98-3.7-315	4.5	100	8	3.0	0.3	Z98-4.5-100
3.7	400	7	3.0	0.3	Z98-3.7-400	4.5	125	8	3.0	0.3	Z98-4.5-125
3.8	100	7	3.0	0.3	Z98-3.8-100	4.5	160	8	3.0	0.3	Z98-4.5-160



Z98

Ejector pin



D1	L	D2	H	R	Order No.	D1	L	D2	H	R	Order No.
4.5	200	8	3.0	0.3	Z98-4.5-200	5.2	200	10	3.0	0.3	Z98-5.2-200
4.5	250	8	3.0	0.3	Z98-4.5-250	5.2	250	10	3.0	0.3	Z98-5.2-250
4.5	315	8	3.0	0.3	Z98-4.5-315	5.2	315	10	3.0	0.3	Z98-5.2-315
4.5	400	8	3.0	0.3	Z98-4.5-400	5.2	400	10	3.0	0.3	Z98-5.2-400
4.5	500	8	3.0	0.3	Z98-4.5-500	5.2	500	10	3.0	0.3	Z98-5.2-500
4.5	630	8	3.0	0.3	Z98-4.5-630	5.2	630	10	3.0	0.3	Z98-5.2-630
4.5	800	8	3.0	0.3	Z98-4.5-800	5.2	800	10	3.0	0.3	Z98-5.2-800
4.5	1000	8	3.0	0.3	Z98-4.5-1000	5.2	1000	10	3.0	0.3	Z98-5.2-1000
4.5	1250	8	3.0	0.3	Z98-4.5-1250	5.2	1250	10	3.0	0.3	Z98-5.2-1250
4.6	100	8	3.0	0.3	Z98-4.6-100	5.3	125	10	3.0	0.3	Z98-5.3-125
4.6	125	8	3.0	0.3	Z98-4.6-125	5.3	160	10	3.0	0.3	Z98-5.3-160
4.6	160	8	3.0	0.3	Z98-4.6-160	5.3	200	10	3.0	0.3	Z98-5.3-200
4.6	200	8	3.0	0.3	Z98-4.6-200	5.3	250	10	3.0	0.3	Z98-5.3-250
4.6	250	8	3.0	0.3	Z98-4.6-250	5.3	400	10	3.0	0.3	Z98-5.3-400
4.6	400	8	3.0	0.3	Z98-4.6-400	5.4	125	10	3.0	0.3	Z98-5.4-125
4.7	100	8	3.0	0.3	Z98-4.7-100	5.4	160	10	3.0	0.3	Z98-5.4-160
4.7	125	8	3.0	0.3	Z98-4.7-125	5.4	200	10	3.0	0.3	Z98-5.4-200
4.7	160	8	3.0	0.3	Z98-4.7-160	5.4	250	10	3.0	0.3	Z98-5.4-250
4.7	200	8	3.0	0.3	Z98-4.7-200	5.4	400	10	3.0	0.3	Z98-5.4-400
4.7	250	8	3.0	0.3	Z98-4.7-250	5.5	100	10	3.0	0.3	Z98-5.5-100
4.7	315	8	3.0	0.3	Z98-4.7-315	5.5	125	10	3.0	0.3	Z98-5.5-125
4.7	400	8	3.0	0.3	Z98-4.7-400	5.5	160	10	3.0	0.3	Z98-5.5-160
4.8	100	8	3.0	0.3	Z98-4.8-100	5.5	200	10	3.0	0.3	Z98-5.5-200
4.8	125	8	3.0	0.3	Z98-4.8-125	5.5	250	10	3.0	0.3	Z98-5.5-250
4.8	160	8	3.0	0.3	Z98-4.8-160	5.5	315	10	3.0	0.3	Z98-5.5-315
4.8	200	8	3.0	0.3	Z98-4.8-200	5.5	400	10	3.0	0.3	Z98-5.5-400
4.8	400	8	3.0	0.3	Z98-4.8-400	5.5	500	10	3.0	0.3	Z98-5.5-500
4.9	100	8	3.0	0.3	Z98-4.9-100	5.5	630	10	3.0	0.3	Z98-5.5-630
4.9	125	8	3.0	0.3	Z98-4.9-125	5.5	800	10	3.0	0.3	Z98-5.5-800
4.9	160	8	3.0	0.3	Z98-4.9-160	5.6	125	10	3.0	0.3	Z98-5.6-125
4.9	200	8	3.0	0.3	Z98-4.9-200	5.6	160	10	3.0	0.3	Z98-5.6-160
4.9	400	8	3.0	0.3	Z98-4.9-400	5.6	200	10	3.0	0.3	Z98-5.6-200
5	40	10	3.0	0.3	Z98-5-40	5.6	250	10	3.0	0.3	Z98-5.6-250
5	63	10	3.0	0.3	Z98-5-63	5.6	400	10	3.0	0.3	Z98-5.6-400
5	80	10	3.0	0.3	Z98-5-80	5.7	125	10	3.0	0.3	Z98-5.7-125
5	100	10	3.0	0.3	Z98-5-100	5.7	160	10	3.0	0.3	Z98-5.7-160
5	125	10	3.0	0.3	Z98-5-125	5.7	200	10	3.0	0.3	Z98-5.7-200
5	160	10	3.0	0.3	Z98-5-160	5.7	250	10	3.0	0.3	Z98-5.7-250
5	200	10	3.0	0.3	Z98-5-200	5.7	400	10	3.0	0.3	Z98-5.7-400
5	250	10	3.0	0.3	Z98-5-250	5.8	125	10	3.0	0.3	Z98-5.8-125
5	315	10	3.0	0.3	Z98-5-315	5.8	160	10	3.0	0.3	Z98-5.8-160
5	400	10	3.0	0.3	Z98-5-400	5.8	200	10	3.0	0.3	Z98-5.8-200
5	500	10	3.0	0.3	Z98-5-500	5.8	250	10	3.0	0.3	Z98-5.8-250
5	630	10	3.0	0.3	Z98-5-630	5.8	400	10	3.0	0.3	Z98-5.8-400
5	800	10	3.0	0.3	Z98-5-800	5.9	160	10	3.0	0.3	Z98-5.9-160
5	1000	10	3.0	0.3	Z98-5-1000	5.9	200	10	3.0	0.3	Z98-5.9-200
5	1250	10	3.0	0.3	Z98-5-1250	5.9	250	10	3.0	0.3	Z98-5.9-250
5.1	100	10	3.0	0.3	Z98-5.1-100	5.9	400	10	3.0	0.3	Z98-5.9-400
5.1	125	10	3.0	0.3	Z98-5.1-125	6	40	12	5.0	0.5	Z98-6-40
5.1	160	10	3.0	0.3	Z98-5.1-160	6	63	12	5.0	0.5	Z98-6-63
5.1	200	10	3.0	0.3	Z98-5.1-200	6	80	12	5.0	0.5	Z98-6-80
5.1	250	10	3.0	0.3	Z98-5.1-250	6	100	12	5.0	0.5	Z98-6-100
5.1	400	10	3.0	0.3	Z98-5.1-400	6	125	12	5.0	0.5	Z98-6-125
5.2	100	10	3.0	0.3	Z98-5.2-100	6	160	12	5.0	0.5	Z98-6-160
5.2	125	10	3.0	0.3	Z98-5.2-125	6	200	12	5.0	0.5	Z98-6-200
5.2	160	10	3.0	0.3	Z98-5.2-160	6	250	12	5.0	0.5	Z98-6-250



Z98

Ejector pin



D1	L	D2	H	R	Order No.	D1	L	D2	H	R	Order No.
6	315	12	5.0	0.5	Z98-6-315	7	800	12	5.0	0.5	Z98-7-800
6	400	12	5.0	0.5	Z98-6-400	7.1	250	12	5.0	0.5	Z98-7.1-250
6	500	12	5.0	0.5	Z98-6-500	7.1	500	12	5.0	0.5	Z98-7.1-500
6	630	12	5.0	0.5	Z98-6-630	7.2	100	12	5.0	0.5	Z98-7.2-100
6	800	12	5.0	0.5	Z98-6-800	7.2	125	12	5.0	0.5	Z98-7.2-125
6	1000	12	5.0	0.5	Z98-6-1000	7.2	160	12	5.0	0.5	Z98-7.2-160
6.1	125	12	5.0	0.5	Z98-6.1-125	7.2	200	12	5.0	0.5	Z98-7.2-200
6.1	160	12	5.0	0.5	Z98-6.1-160	7.2	250	12	5.0	0.5	Z98-7.2-250
6.1	200	12	5.0	0.5	Z98-6.1-200	7.2	500	12	5.0	0.5	Z98-7.2-500
6.1	250	12	5.0	0.5	Z98-6.1-250	7.3	250	12	5.0	0.5	Z98-7.3-250
6.1	315	12	5.0	0.5	Z98-6.1-315	7.3	500	12	5.0	0.5	Z98-7.3-500
6.1	400	12	5.0	0.5	Z98-6.1-400	7.4	250	12	5.0	0.5	Z98-7.4-250
6.2	100	12	5.0	0.5	Z98-6.2-100	7.5	100	12	5.0	0.5	Z98-7.5-100
6.2	125	12	5.0	0.5	Z98-6.2-125	7.5	125	12	5.0	0.5	Z98-7.5-125
6.2	160	12	5.0	0.5	Z98-6.2-160	7.5	160	12	5.0	0.5	Z98-7.5-160
6.2	200	12	5.0	0.5	Z98-6.2-200	7.5	200	12	5.0	0.5	Z98-7.5-200
6.2	250	12	5.0	0.5	Z98-6.2-250	7.5	250	12	5.0	0.5	Z98-7.5-250
6.2	315	12	5.0	0.5	Z98-6.2-315	7.5	315	12	5.0	0.5	Z98-7.5-315
6.2	400	12	5.0	0.5	Z98-6.2-400	7.5	400	12	5.0	0.5	Z98-7.5-400
6.2	500	12	5.0	0.5	Z98-6.2-500	7.5	500	12	5.0	0.5	Z98-7.5-500
6.2	630	12	5.0	0.5	Z98-6.2-630	7.6	250	14	5.0	0.5	Z98-7.6-250
6.2	800	12	5.0	0.5	Z98-6.2-800	7.6	500	14	5.0	0.5	Z98-7.6-500
6.2	1000	12	5.0	0.5	Z98-6.2-1000	7.7	250	14	5.0	0.5	Z98-7.7-250
6.2	1250	12	5.0	0.5	Z98-6.2-1250	7.8	250	14	5.0	0.5	Z98-7.8-250
6.3	125	12	5.0	0.5	Z98-6.3-125	7.8	500	14	5.0	0.5	Z98-7.8-500
6.3	200	12	5.0	0.5	Z98-6.3-200	7.9	250	14	5.0	0.5	Z98-7.9-250
6.3	250	12	5.0	0.5	Z98-6.3-250	8	63	14	5.0	0.5	Z98-8-63
6.3	400	12	5.0	0.5	Z98-6.3-400	8	80	14	5.0	0.5	Z98-8-80
6.4	125	12	5.0	0.5	Z98-6.4-125	8	100	14	5.0	0.5	Z98-8-100
6.4	200	12	5.0	0.5	Z98-6.4-200	8	125	14	5.0	0.5	Z98-8-125
6.4	250	12	5.0	0.5	Z98-6.4-250	8	160	14	5.0	0.5	Z98-8-160
6.4	400	12	5.0	0.5	Z98-6.4-400	8	200	14	5.0	0.5	Z98-8-200
6.5	100	12	5.0	0.5	Z98-6.5-100	8	250	14	5.0	0.5	Z98-8-250
6.5	125	12	5.0	0.5	Z98-6.5-125	8	315	14	5.0	0.5	Z98-8-315
6.5	160	12	5.0	0.5	Z98-6.5-160	8	400	14	5.0	0.5	Z98-8-400
6.5	200	12	5.0	0.5	Z98-6.5-200	8	500	14	5.0	0.5	Z98-8-500
6.5	250	12	5.0	0.5	Z98-6.5-250	8	630	14	5.0	0.5	Z98-8-630
6.5	315	12	5.0	0.5	Z98-6.5-315	8	800	14	5.0	0.5	Z98-8-800
6.5	400	12	5.0	0.5	Z98-6.5-400	8	1000	14	5.0	0.5	Z98-8-1000
6.5	500	12	5.0	0.5	Z98-6.5-500	8.1	125	14	5.0	0.5	Z98-8.1-125
6.5	630	12	5.0	0.5	Z98-6.5-630	8.1	200	14	5.0	0.5	Z98-8.1-200
6.8	200	12	5.0	0.5	Z98-6.8-200	8.1	250	14	5.0	0.5	Z98-8.1-250
6.8	250	12	5.0	0.5	Z98-6.8-250	8.1	500	14	5.0	0.5	Z98-8.1-500
6.8	500	12	5.0	0.5	Z98-6.8-500	8.2	100	14	5.0	0.5	Z98-8.2-100
6.9	125	12	5.0	0.5	Z98-6.9-125	8.2	125	14	5.0	0.5	Z98-8.2-125
6.9	200	12	5.0	0.5	Z98-6.9-200	8.2	160	14	5.0	0.5	Z98-8.2-160
6.9	250	12	5.0	0.5	Z98-6.9-250	8.2	200	14	5.0	0.5	Z98-8.2-200
7	100	12	5.0	0.5	Z98-7-100	8.2	250	14	5.0	0.5	Z98-8.2-250
7	125	12	5.0	0.5	Z98-7-125	8.2	315	14	5.0	0.5	Z98-8.2-315
7	160	12	5.0	0.5	Z98-7-160	8.2	400	14	5.0	0.5	Z98-8.2-400
7	200	12	5.0	0.5	Z98-7-200	8.2	500	14	5.0	0.5	Z98-8.2-500
7	250	12	5.0	0.5	Z98-7-250	8.2	630	14	5.0	0.5	Z98-8.2-630
7	315	12	5.0	0.5	Z98-7-315	8.2	800	14	5.0	0.5	Z98-8.2-800
7	400	12	5.0	0.5	Z98-7-400	8.2	1000	14	5.0	0.5	Z98-8.2-1000
7	500	12	5.0	0.5	Z98-7-500	8.2	1250	14	5.0	0.5	Z98-8.2-1250
7	630	12	5.0	0.5	Z98-7-630	8.4	250	14	5.0	0.5	Z98-8.4-250



Z98

Ejector pin



D1	L	D2	H	R	Order No.	D1	L	D2	H	R	Order No.
8.4	500	14	5.0	0.5	Z98-8.4-500	10	200	16	5.0	0.5	Z98-10-200
8.5	100	14	5.0	0.5	Z98-8.5-100	10	250	16	5.0	0.5	Z98-10-250
8.5	125	14	5.0	0.5	Z98-8.5-125	10	315	16	5.0	0.5	Z98-10-315
8.5	160	14	5.0	0.5	Z98-8.5-160	10	400	16	5.0	0.5	Z98-10-400
8.5	200	14	5.0	0.5	Z98-8.5-200	10	500	16	5.0	0.5	Z98-10-500
8.5	250	14	5.0	0.5	Z98-8.5-250	10	630	16	5.0	0.5	Z98-10-630
8.5	315	14	5.0	0.5	Z98-8.5-315	10	800	16	5.0	0.5	Z98-10-800
8.5	400	14	5.0	0.5	Z98-8.5-400	10	1000	16	5.0	0.5	Z98-10-1000
8.5	500	14	5.0	0.5	Z98-8.5-500	10.1	200	16	5.0	0.5	Z98-10.1-200
8.5	630	14	5.0	0.5	Z98-8.5-630	10.1	250	16	5.0	0.5	Z98-10.1-250
8.6	160	14	5.0	0.5	Z98-8.6-160	10.1	400	16	5.0	0.5	Z98-10.1-400
8.6	315	14	5.0	0.5	Z98-8.6-315	10.2	100	16	5.0	0.5	Z98-10.2-100
8.7	160	14	5.0	0.5	Z98-8.7-160	10.2	125	16	5.0	0.5	Z98-10.2-125
8.7	315	14	5.0	0.5	Z98-8.7-315	10.2	160	16	5.0	0.5	Z98-10.2-160
8.8	160	14	5.0	0.5	Z98-8.8-160	10.2	200	16	5.0	0.5	Z98-10.2-200
8.8	315	14	5.0	0.5	Z98-8.8-315	10.2	250	16	5.0	0.5	Z98-10.2-250
8.9	160	14	5.0	0.5	Z98-8.9-160	10.2	315	16	5.0	0.5	Z98-10.2-315
8.9	315	14	5.0	0.5	Z98-8.9-315	10.2	400	16	5.0	0.5	Z98-10.2-400
9	80	14	5.0	0.5	Z98-9-80	10.2	500	16	5.0	0.5	Z98-10.2-500
9	100	14	5.0	0.5	Z98-9-100	10.2	630	16	5.0	0.5	Z98-10.2-630
9	125	14	5.0	0.5	Z98-9-125	10.5	100	16	5.0	0.5	Z98-10.5-100
9	160	14	5.0	0.5	Z98-9-160	10.5	125	16	5.0	0.5	Z98-10.5-125
9	200	14	5.0	0.5	Z98-9-200	10.5	160	16	5.0	0.5	Z98-10.5-160
9	250	14	5.0	0.5	Z98-9-250	10.5	200	16	5.0	0.5	Z98-10.5-200
9	315	14	5.0	0.5	Z98-9-315	10.5	250	16	5.0	0.5	Z98-10.5-250
9	400	14	5.0	0.5	Z98-9-400	10.5	315	16	5.0	0.5	Z98-10.5-315
9	500	14	5.0	0.5	Z98-9-500	10.5	400	16	5.0	0.5	Z98-10.5-400
9	630	14	5.0	0.5	Z98-9-630	10.5	500	16	5.0	0.5	Z98-10.5-500
9.1	200	14	5.0	0.5	Z98-9.1-200	10.5	630	16	5.0	0.5	Z98-10.5-630
9.1	400	14	5.0	0.5	Z98-9.1-400	11	160	16	5.0	0.5	Z98-11-160
9.2	200	14	5.0	0.5	Z98-9.2-200	11	200	16	5.0	0.5	Z98-11-200
9.2	400	14	5.0	0.5	Z98-9.2-400	11	250	16	5.0	0.5	Z98-11-250
9.2	630	14	5.0	0.5	Z98-9.2-630	11	315	16	5.0	0.5	Z98-11-315
9.3	200	14	5.0	0.5	Z98-9.3-200	11	400	16	5.0	0.5	Z98-11-400
9.3	400	14	5.0	0.5	Z98-9.3-400	11	500	16	5.0	0.5	Z98-11-500
9.4	200	14	5.0	0.5	Z98-9.4-200	11	630	16	5.0	0.5	Z98-11-630
9.4	400	14	5.0	0.5	Z98-9.4-400	11.5	200	16	5.0	0.5	Z98-11.5-200
9.5	100	14	5.0	0.5	Z98-9.5-100	11.5	400	16	5.0	0.5	Z98-11.5-400
9.5	125	14	5.0	0.5	Z98-9.5-125	11.5	630	16	5.0	0.5	Z98-11.5-630
9.5	160	14	5.0	0.5	Z98-9.5-160	12	80	18	7.0	0.8	Z98-12-80
9.5	200	14	5.0	0.5	Z98-9.5-200	12	100	18	7.0	0.8	Z98-12-100
9.5	315	14	5.0	0.5	Z98-9.5-315	12	125	18	7.0	0.8	Z98-12-125
9.5	400	14	5.0	0.5	Z98-9.5-400	12	160	18	7.0	0.8	Z98-12-160
9.5	630	14	5.0	0.5	Z98-9.5-630	12	200	18	7.0	0.8	Z98-12-200
9.6	200	16	5.0	0.5	Z98-9.6-200	12	250	18	7.0	0.8	Z98-12-250
9.6	400	16	5.0	0.5	Z98-9.6-400	12	315	18	7.0	0.8	Z98-12-315
9.7	200	16	5.0	0.5	Z98-9.7-200	12	400	18	7.0	0.8	Z98-12-400
9.7	400	16	5.0	0.5	Z98-9.7-400	12	500	18	7.0	0.8	Z98-12-500
9.8	200	16	5.0	0.5	Z98-9.8-200	12	630	18	7.0	0.8	Z98-12-630
9.8	400	16	5.0	0.5	Z98-9.8-400	12	800	18	7.0	0.8	Z98-12-800
9.9	200	16	5.0	0.5	Z98-9.9-200	12	1000	18	7.0	0.8	Z98-12-1000
9.9	400	16	5.0	0.5	Z98-9.9-400	12.1	250	18	7.0	0.8	Z98-12.1-250
10	80	16	5.0	0.5	Z98-10-80	12.2	80	18	7.0	0.8	Z98-12.2-80
10	100	16	5.0	0.5	Z98-10-100	12.2	100	18	7.0	0.8	Z98-12.2-100
10	125	16	5.0	0.5	Z98-10-125	12.2	125	18	7.0	0.8	Z98-12.2-125
10	160	16	5.0	0.5	Z98-10-160	12.2	160	18	7.0	0.8	Z98-12.2-160

Z98
Ejector pin

D1	L	D2	H	R	Order No.
12.2	200	18	7.0	0.8	Z98-12.2-200
12.2	250	18	7.0	0.8	Z98-12.2-250
12.2	315	18	7.0	0.8	Z98-12.2-315
12.2	400	18	7.0	0.8	Z98-12.2-400
12.2	500	18	7.0	0.8	Z98-12.2-500
12.5	100	18	7.0	0.8	Z98-12.5-100
12.5	125	18	7.0	0.8	Z98-12.5-125
12.5	160	18	7.0	0.8	Z98-12.5-160
12.5	200	18	7.0	0.8	Z98-12.5-200
12.5	250	18	7.0	0.8	Z98-12.5-250
12.5	315	18	7.0	0.8	Z98-12.5-315
12.5	400	18	7.0	0.8	Z98-12.5-400
12.5	500	18	7.0	0.8	Z98-12.5-500
12.5	630	18	7.0	0.8	Z98-12.5-630
13	100	18	7.0	0.8	Z98-13-100
13	125	18	7.0	0.8	Z98-13-125
13	160	18	7.0	0.8	Z98-13-160
13	200	18	7.0	0.8	Z98-13-200
13	250	18	7.0	0.8	Z98-13-250
13	315	18	7.0	0.8	Z98-13-315
13	400	18	7.0	0.8	Z98-13-400
13	500	18	7.0	0.8	Z98-13-500
13	630	18	7.0	0.8	Z98-13-630
13.5	100	22	7.0	0.8	Z98-13.5-100
13.5	125	22	7.0	0.8	Z98-13.5-125
13.5	160	22	7.0	0.8	Z98-13.5-160
13.5	200	22	7.0	0.8	Z98-13.5-200
13.5	250	22	7.0	0.8	Z98-13.5-250
13.5	315	22	7.0	0.8	Z98-13.5-315
13.5	400	22	7.0	0.8	Z98-13.5-400
13.5	500	22	7.0	0.8	Z98-13.5-500
13.5	630	22	7.0	0.8	Z98-13.5-630
14	100	22	7.0	0.8	Z98-14-100
14	125	22	7.0	0.8	Z98-14-125
14	160	22	7.0	0.8	Z98-14-160
14	200	22	7.0	0.8	Z98-14-200
14	250	22	7.0	0.8	Z98-14-250
14	315	22	7.0	0.8	Z98-14-315
14	400	22	7.0	0.8	Z98-14-400
14	500	22	7.0	0.8	Z98-14-500
14	630	22	7.0	0.8	Z98-14-630
14	800	22	7.0	0.8	Z98-14-800
14	1000	22	7.0	0.8	Z98-14-1000
14.5	100	22	7.0	0.8	Z98-14.5-100
14.5	125	22	7.0	0.8	Z98-14.5-125
14.5	160	22	7.0	0.8	Z98-14.5-160
14.5	200	22	7.0	0.8	Z98-14.5-200
14.5	250	22	7.0	0.8	Z98-14.5-250
14.5	315	22	7.0	0.8	Z98-14.5-315
14.5	400	22	7.0	0.8	Z98-14.5-400
14.5	630	22	7.0	0.8	Z98-14.5-630
15	100	22	7.0	0.8	Z98-15-100
15	125	22	7.0	0.8	Z98-15-125

D1	L	D2	H	R	Order No.
15	160	22	7.0	0.8	Z98-15-160
15	200	22	7.0	0.8	Z98-15-200
15	250	22	7.0	0.8	Z98-15-250
15	400	22	7.0	0.8	Z98-15-400
15	630	22	7.0	0.8	Z98-15-630
16	100	22	7.0	0.8	Z98-16-100
16	125	22	7.0	0.8	Z98-16-125
16	160	22	7.0	0.8	Z98-16-160
16	200	22	7.0	0.8	Z98-16-200
16	250	22	7.0	0.8	Z98-16-250
16	315	22	7.0	0.8	Z98-16-315
16	400	22	7.0	0.8	Z98-16-400
16	500	22	7.0	0.8	Z98-16-500
16	630	22	7.0	0.8	Z98-16-630
16	800	22	7.0	0.8	Z98-16-800
16	1000	22	7.0	0.8	Z98-16-1000
16.2	200	22	7.0	0.8	Z98-16.2-200
16.2	400	22	7.0	0.8	Z98-16.2-400
16.5	200	22	7.0	0.8	Z98-16.5-200
16.5	250	22	7.0	0.8	Z98-16.5-250
16.5	400	22	7.0	0.8	Z98-16.5-400
18	160	24	7.0	0.8	Z98-18-160
18	200	24	7.0	0.8	Z98-18-200
18	250	24	7.0	0.8	Z98-18-250
18	315	24	7.0	0.8	Z98-18-315
18	400	24	7.0	0.8	Z98-18-400
18	500	24	7.0	0.8	Z98-18-500
18	630	24	7.0	0.8	Z98-18-630
20	100	26	8.0	1.0	Z98-20-100
20	125	26	8.0	1.0	Z98-20-125
20	160	26	8.0	1.0	Z98-20-160
20	200	26	8.0	1.0	Z98-20-200
20	250	26	8.0	1.0	Z98-20-250
20	315	26	8.0	1.0	Z98-20-315
20	400	26	8.0	1.0	Z98-20-400
20	500	26	8.0	1.0	Z98-20-500
20	630	26	8.0	1.0	Z98-20-630
20	800	26	8.0	1.0	Z98-20-800
20	1000	26	8.0	1.0	Z98-20-1000
20.5	250	26	8.0	1.0	Z98-20.5-250
20.5	400	26	8.0	1.0	Z98-20.5-400
22	160	28	8.0	1.0	Z98-22-160
22	250	28	8.0	1.0	Z98-22-250
22	400	28	8.0	1.0	Z98-22-400
25	125	32	10.0	1.0	Z98-25-125
25	160	32	10.0	1.0	Z98-25-160
25	200	32	10.0	1.0	Z98-25-200
25	250	32	10.0	1.0	Z98-25-250
25	315	32	10.0	1.0	Z98-25-315
25	400	32	10.0	1.0	Z98-25-400
25	500	32	10.0	1.0	Z98-25-500
25	630	32	10.0	1.0	Z98-25-630