

## Gasdruckfedern MICROserie

## Gas springs MICROseries

## Ressorts à gaz MICROsérie

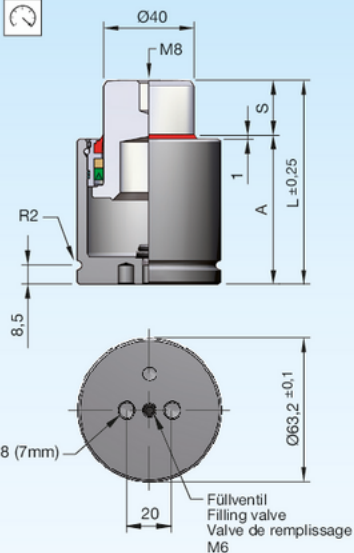

### Einbauvarianten / Installation variants / Variantes de montage

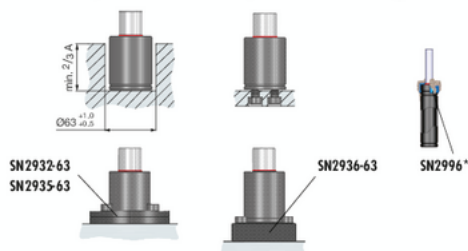

Druckmedium	Pressure medium	Médium de pression	Stickstoff (N <sub>2</sub> )
Max. Fülldruck	Max. filling pressure	Pression de rempl. max.	150 bar
Min. Fülldruck	Min. filling pressure	Pression de rempl. min.	35 bar
Max. Betriebs-temperatur	Max. working temperature	Température de service max.	80 °C
Temperaturabhängige Druckerhöhung	Pressure increase due to temperature	Accroissement de pression sous l'influence de la temp.	0,33 %/1 °C
Instandhaltungsset	Maintenance kit	Jeu de maintenance	SN2990-M63
Max. Kolben-geschwindigkeit	Max. piston speed	Vitesse max. du piston	0,6 m/s

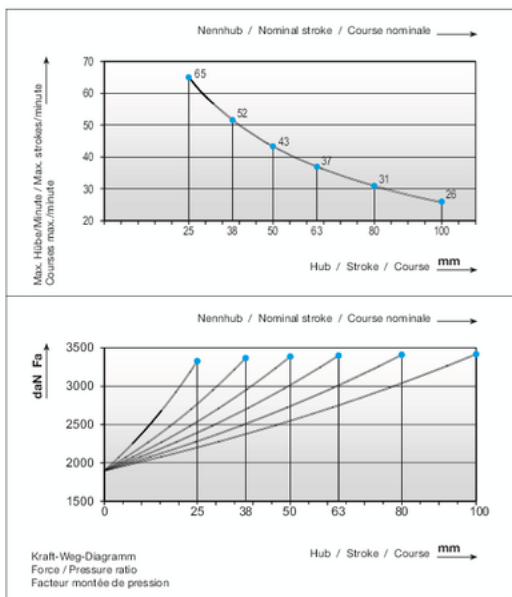

### SN2808-1900-



SN2808-1900-S



S



daN



daN

bar

A

L

V

[l]

Fa

[cm<sup>2</sup>]

kg

S = Hub / Stroke / Course

bar = Fülldruck / Filling pressure / Pression de remplissage

\* i SN2996 = Seite / Page 2.3.254