

Gasdruckfedern TITANserie

Gas springs TITANseries

Ressorts à gaz TITANsérie

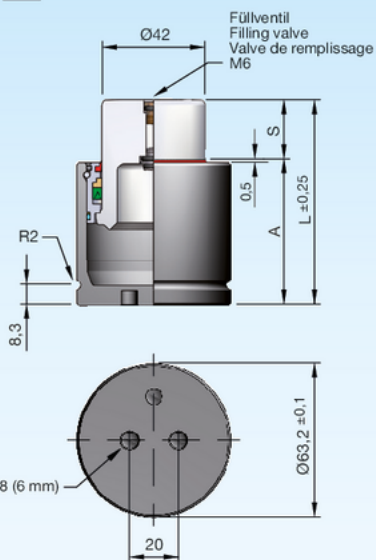

3

Druckmedium	Pressure medium	Médium de pression	Stickstoff (N ₂)
Max. Fülldruck	Max. filling pressure	Pression de rempl. max.	150 bar
Min. Fülldruck	Min. filling pressure	Pression de rempl. min.	50 bar
Max. Betriebs-temperatur	Max. working temperature	Température de service max.	80 °C
Temperaturabhängige Druckerhöhung	Pressure increase due to temperature	Accroissement de pression sous l'influence de la temp.	0,33 %/1 °C
Instandhaltungssatz	Maintenance kit	Jeu de maintenance	SN2990-T63
Max. Kolben-geschwindigkeit	Max. piston speed	Vitesse max. du piston	0,8 m/s

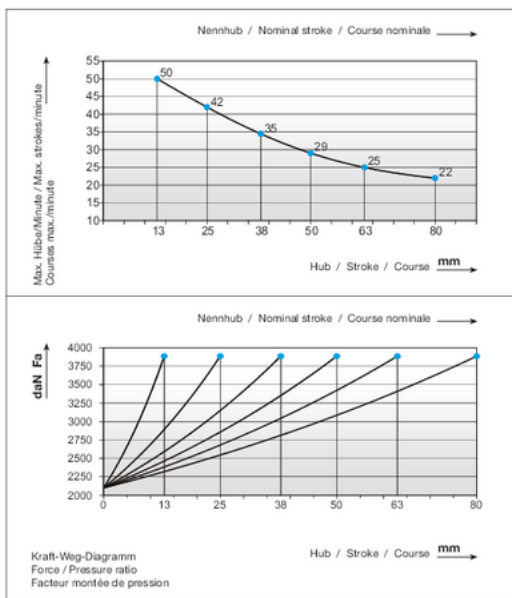

Einbauvarianten / Installation variants / Variantes de montage

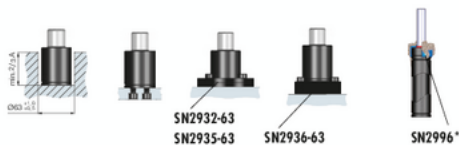

SN2807-2100-



SN2807-2100-S



S	daN	daN	bar	A	L	V [l]	Fa [cm ²]	kg
13	2100	3845	150	47	60	0,039	13,85	0,87
25	(±5%)	3845	150	59	84	0,075	13,85	0,92
38		3845	150	72	110	0,115	13,85	1,30
50		3845	150	84	134	0,151	13,85	1,55
63		3845	150	97	160	0,190	13,85	1,70
80		3845	150	114	194	0,241	13,85	1,85

* i SN2996 - Seite / Page 2.3.254