

Gasdruckfedern TITANserie

Gas springs TITANseries

Ressorts à gaz TITANsérie

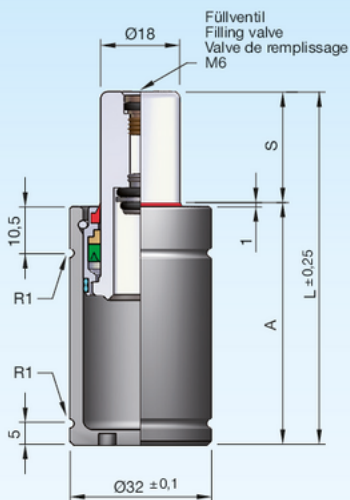

3

Druckmedium	Pressure medium	Médium de pression	Stickstoff (N ₂)
Max. Fülldruck	Max. filling pressure	Pression de rempl. max.	190 bar
Min. Fülldruck	Min. filling pressure	Pression de rempl. min.	25 bar
Max. Betriebs-temperatur	Max. working temperature	Température de service max.	80 °C
Temperaturabhängige Druckerhöhung	Pressure increase due to temperature	Accroissement de pression sous l'influence de la temp.	0,33 %/1 °C
Instandhaltungssatz	Maintenance kit	Jeu de maintenance	SN2990-T32
Max. Kolben-geschwindigkeit	Max. piston speed	Vitesse max. du piston	1,2 m/s

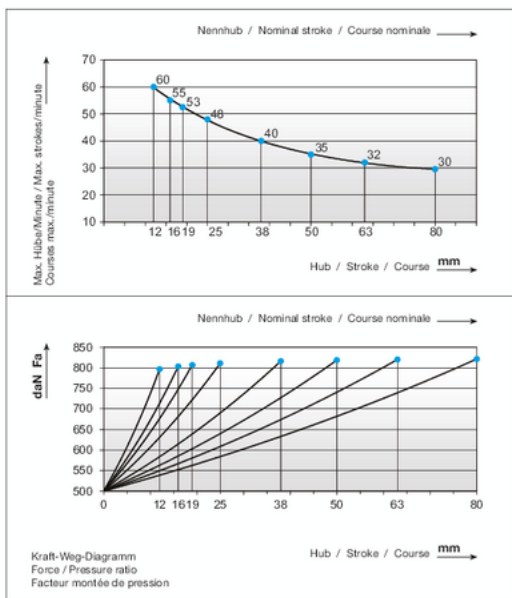

Einbauvarianten / Installation variants / Variantes de montage



SN2807-500-



SN2807-500-S



S = Hub / Stroke / Course

bar = Fülldruck / Filling pressure / Pression de remplissage

* i SN2996 = Seite / Page 2.3.254

S	daN	daN	bar	A	L	V [l]	Fa [cm ²]	kg
12	500	800	190	37	49	0,008	2,54	0,19
16	(±5%)	805	190	42	58	0,011	2,54	0,21
19		810	190	46	65	0,013	2,54	0,22
25		815	190	51	76	0,017	2,54	0,24
38		820	190	64	102	0,025	2,54	0,27
50		820	190	77	127	0,033	2,54	0,30
63		825	190	89	152	0,041	2,54	0,34
80		825	190	106	186	0,052	2,54	0,41