

## Schneidstempel

## Cutting punches

## Poinçons de découpe

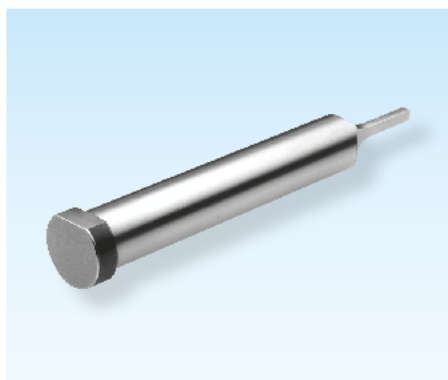

**SN1868C-HSS-0 - (90)**

Mat.: HSS (1.3343)  
DIN ISO 8020 BS/BR/BO

SN1868C-HSS-  
Type-a-b-L1-d3

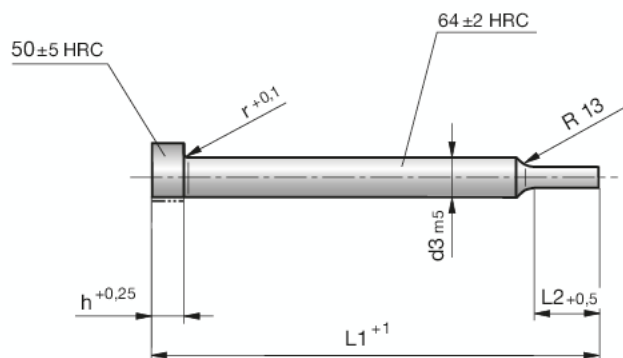

4

X\* — Stufung in mm  
— graduation in mm  
— progression en mm

<sup>1)</sup> L2 = Vorschlaglänge, andere Längen bei Bestellung angeben.  
Recommended length, please indicate other length in the order.  
Longueur recommandée, veuillez indiquer autres longueurs dans la commande.

### Type 1 (BS)

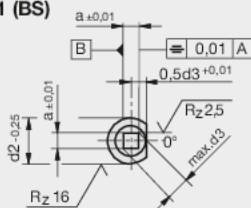

### Type 2 (BR)

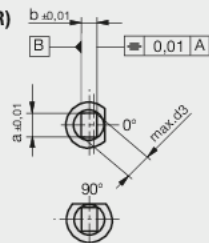

### Type 3 (BO)

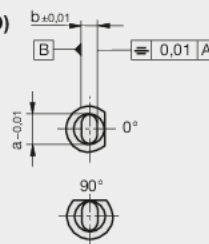

Type	a	b	L1	d3	d2	h	X*(a/b)	L2 <sup>1)</sup>	r
1			71/80	6	9	5	0,1	13	0,3
2				6	9	5	0,1	13	0,3
3				6	9	5	0,1	13	0,3
1	Nach Wahl des Bestellers		71/80	8	11	5	0,1	13	0,3
2				8	11	5	0,1	13	0,3
3					8	11	5	0,1	13
1	At customer's option		71/80	10	13	5	0,1	13	0,3
2				10	13	5	0,1	13	0,3
3					10	13	5	0,1	13
1	Au choix du client		71/80/	13	16	5	0,1	13	0,4
2			100	13	16	5	0,1	13	0,4
3					13	16	5	0,1	13
1			80/100	16	19	5	0,1	13	0,4
2				16	19	5	0,1	13	0,4
3				16	19	5	0,1	13	0,4
1			80/100	20	23	5	0,1	13	0,4
2				20	23	5	0,1	13	0,4
3				20	23	5	0,1	13	0,4
1			80/100	25	28	5	0,1	13	0,4
2				25	28	5	0,1	13	0,4
3				25	28	5	0,1	13	0,4
1			80/100	32	35	5	0,1	13	0,4
2				32	35	5	0,1	13	0,4
3				32	35	5	0,1	13	0,4

D 3002A 07.2018