

CAD STANDARD PARTS FOR NX MOLD WIZARD

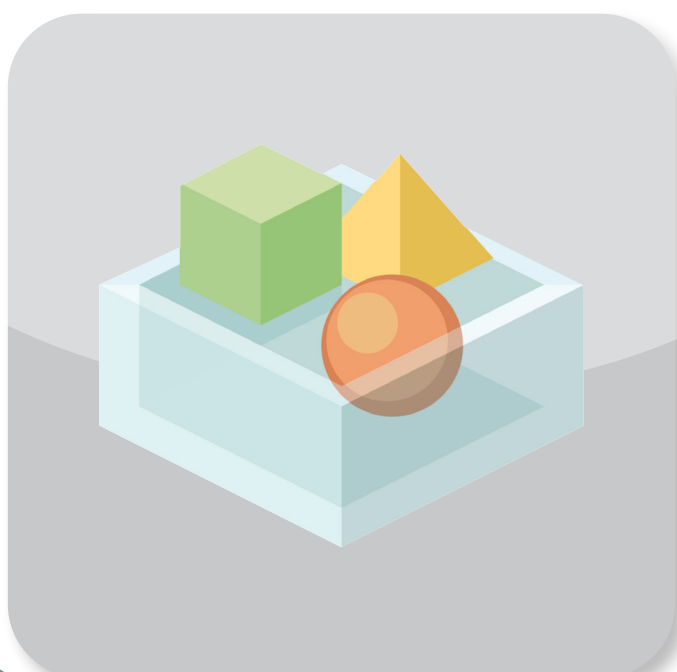

CIMTEC



more than
120.000 parts
and variants

over 90
manufacturers
and suppliers



Parameters
Attributes
Tolerancing

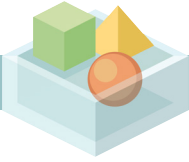

➤➤ „LESS IS MORE“



➤➤ CAD NT App for NX Mold Wizard

NX Mold Wizard is the wizard for mould design in Siemens NX. Experienced NX users appreciate its functionality, time saving by speeding up the design process and more reliability

3/4 of all components are standard parts

Experienced users know that, about 3/4 of all parts assembled in a mould design, belong to the group of standard parts. These mould standard parts are mainly delivered by specialised suppliers.

A part of the group of suppliers for mould standard parts are general manufacturers, such as DME, Hasco, Knarr, Meusburger or Strack. Apart from these, there are specialists offering standard parts which often consist of more complex parts or assemblies and are mostly needed in a smaller quantities.

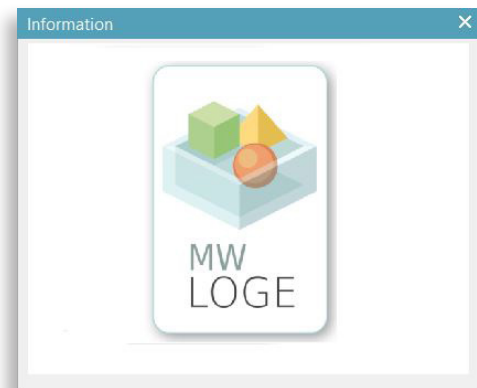

Using CAD-data from standard part manufacturers ist time consuming

Generalists provide 3D-data of their standard parts, mostly unparametric bodies, representing the exact geometry. This data often has to be prepared before being used in a high-end CAD-system - such as Siemens NX - and placed into a mould design.

Most mould shops use standard parts from various manufacturers in their moulds. Thus, mould designers are forced to search for parts in numerous catalogues and - as they are built up differently - adopt and edit individually.

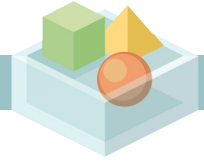

Creating a Bill of Material: time consuming and error-prone

During the mould design process, designers have to deal with each part of the mould - while creating the bill of material.

Attention has to be paid in order to avoid wrong orders, usually causing trouble as well as costing time and money.

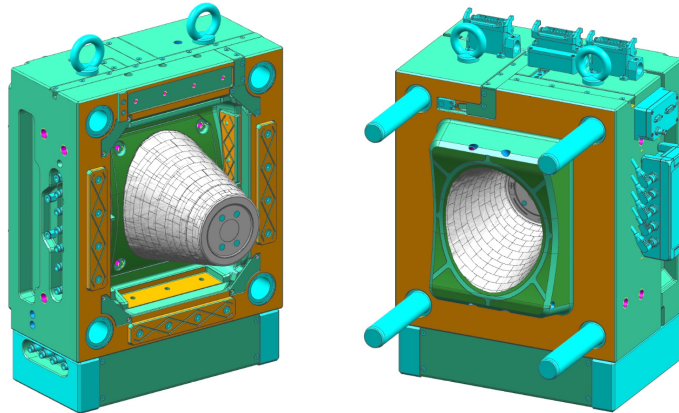

Drawings make mould design expensive

Another highly time consuming step is the creation of drawings. Drafting or deriving drawings from the mould design was a mandatory step, as a 3D model did not allow to draw any conclusion concerning surface quality or tolerances.

Time is also involved in the process of deriving/drafting drawings from 3D models. Drawings were necessary for a user who could not get information concerning surface quality and tolerances from a plain model.

Realising this, the Mold Wizard Loge's members decided to take another path, avoiding these disadvantages:

Standard part in the NT App library are full parametric models, being configured using spreadsheets. Thus, parts fitting for several standard part manufacturers catalogues have been created. Parameters for shape and size are available in Mold Wizard through spreadsheets:

>>> THE ACHIEVEMENT / THE RESULT:

- **ONE standard part catalogue.**
- **Without any additional rework, the models may be placed into the mould designed using Siemens NX.**

Information attached to the standard parts allow to directly order them from Mold Wizard's bill of material.

Each face of a standard part's false body has been coloured, representing information of dimensions/tolerances, even surface quality or manufacturing method where possible. An indispensable prerequisite for a workflow with little or even without paper.

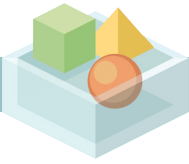

Standard Part Selection: conventional workflow

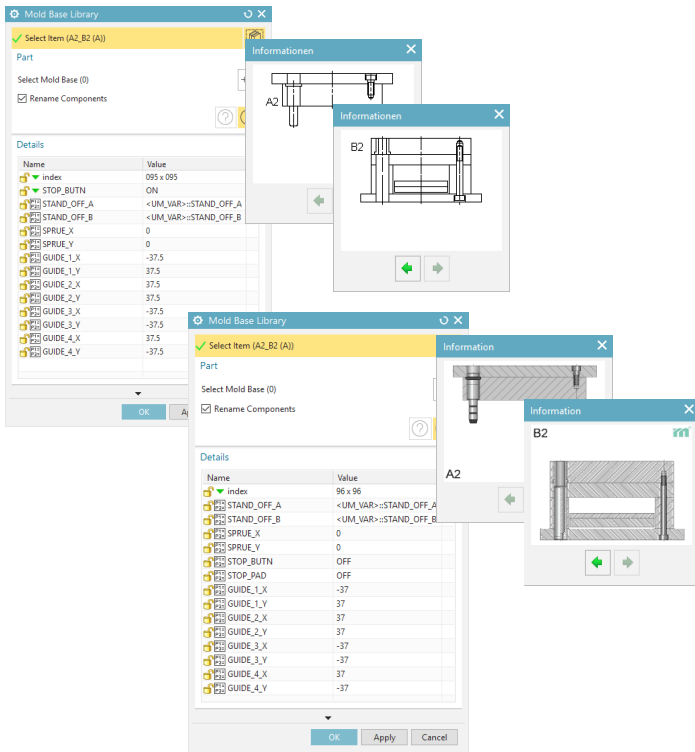

Using in NX Mold Wizard, a mould designer needs to collect models of the specific part needed from a certain supplier's database.

As all suppliers have their individual scheme of design, these parts have to be edited before using them in a mould design.

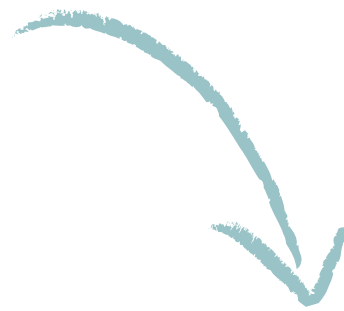

Standard Part Selection: NT App

In NT App, standard parts are set up parametrically and in a unified way of design.

Scrolling through catalogues and comparing variants from various manufacturers is not necessary anymore. On change, the BoM list entry is being changed automatically.

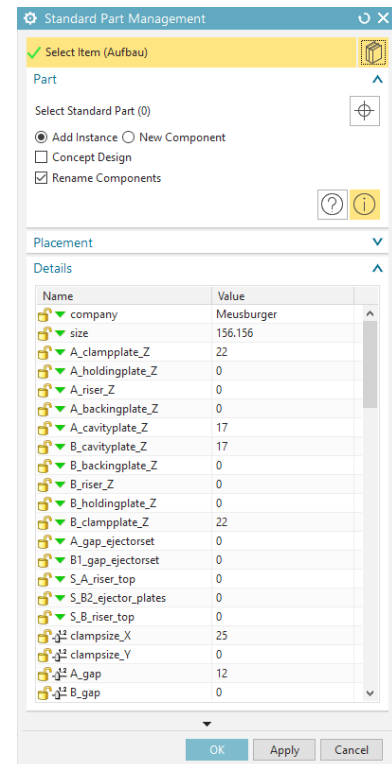
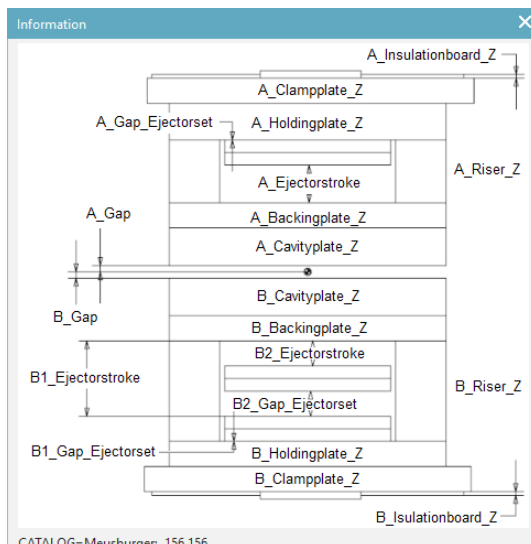

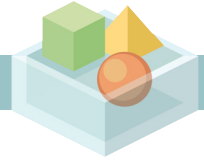

Standard Part Selection: conventional workflow

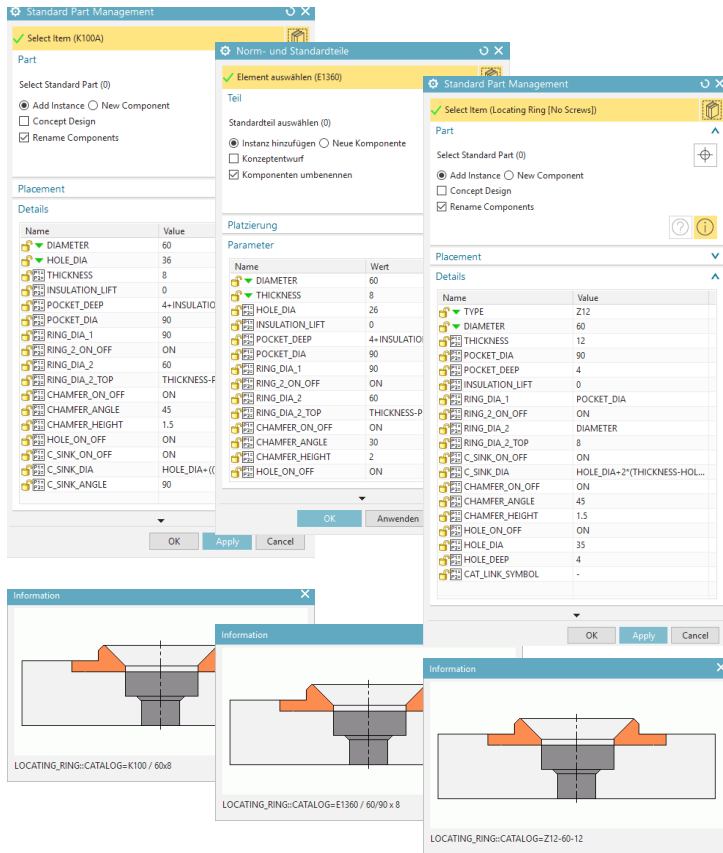

Time consuming

- Search through numerous files
- Rework of the standards part's models

The designer searches using his knowledge and experience: mostly by fixed dimensions or order numbers.

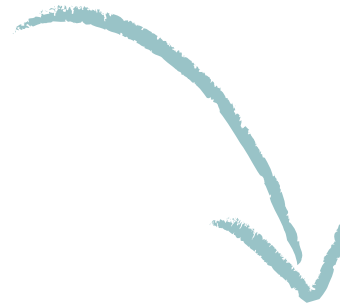

Standard Part Selection: NT App

Advantages:

- ONE catalogue
- use full parametric standard parts in NX mould design instantly
- changing standard parts without additional work - changing parameters updates part automatically

Parts are found by descriptive names or order numbers. A standard part's parameters represent its available size and variants. Future changes of e.g. dimensions or the supplier may be realised without a problem.

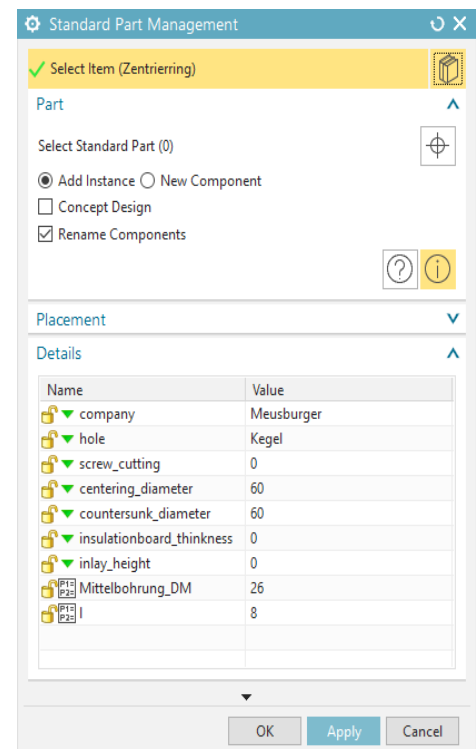
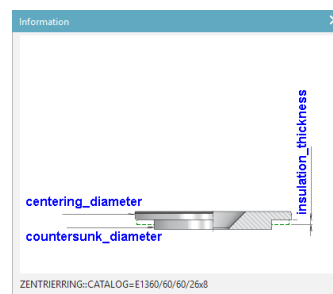

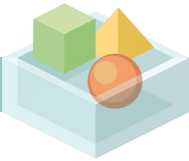

Selection offers multivendor capability

Name	Wert
Firma	DME
Gew_D	8
Bohrwinkel	118
Ringnut	Nein
Werkzeugseite	A

- Meusburger
- Meusburger
- Hasco
- Strack
- DME
- Rud
- Pfeifer
- JDT
- Codipro
- Hebegewinde

standard part selection by descriptive names (ca. 400 variants)

parameters and dimensions

basic information about the standard part

Detailed information about the standard part (e.g. supplier catalogue entry)

Name	Standard
Ejector rod assembly (Meusburger E1050 Hasco Z02 Strack Z144)	Mold
Ejector rod (Meusburger E1519)	Mold
Coupling spigot (Hasco Z1591)	Mold
Ejection unit (Meusburger E3200)	Mold
Ejection unit (Meusburger E3202)	Mold
Ejector set guiding unit (Meusburger E1064)	Mold
Ejector set coupling (Meusburger E1804)	Mold
Ejector set dowel coupling (Staeubli QMC400.125.65 QMC400...	Mold
Ejector set dowel coupling (Meusburger E1517 E1518 DME AR0...	Mold
Transparent and magnetic ejector set cover (Meusburger E192...	Mold
Ejector set accelerator (Meusburger E1524)	Mold
Automatic ejector set lock (Meusburger E1940)	Mold
Pressure disk foro pusher guide ejector set (Meusburger E1802)	Mold
Ejector set threaded bolt (Meusburger E1514)	Mold
Ejector set threaded insert (Meusburger E1515)	Mold
Ejector set asm threaded insert (Meusburger E1516)	Mold
Extension rod (Hasco Z47)	Mold
Ejector slider lifter (Meusburger E3250 E3252)	Mold
Ventilation valve (Meusburger E1670 E16709 E1673 Hasco Z491 ...	Mold

CATALOG=E1270/8
INFO::CATALOG=Z1: 140 kg
INFO::CATALOG=Z2: 100 kg

Name	Value
company	Meusburger
Type_guide_plate	Fuehrungsleiste_verbohrt
height	12
width	20
length	50
bolt_length	60
Screw_length	20
mirror_gliding_plate	0
side_slide	B
side_cotter	A
Fuehr_Hoeh	6
Abstand_Schieber	7.4

CATALOG=E 3012/12/20/30



Standard Part Management

Select Item (Aufbau)

Part

Select Standard Part (0)

Add Instance New Component

Concept Design

Rename Components

Placement

Details

Name	Value
company	Meusburger
size	156.156
A_clampplate_Z	22
A_holdingplate_Z	0
A_riser_Z	0
A_backingplate_Z	0
A_cavityplate_Z	17
B_cavityplate_Z	17
B_backingplate_Z	0
B_riser_Z	0
B_holdingplate_Z	0
B_clampplate_Z	22
A_gap_ejectorset	0
B1_gap_ejectorset	0
S_A_Leiste_oben	0
S_B2_Auswerferpaket	0
S_B_Leiste_oben	0
Aufspannrand_X	25

Settings

OK Apply Cancel

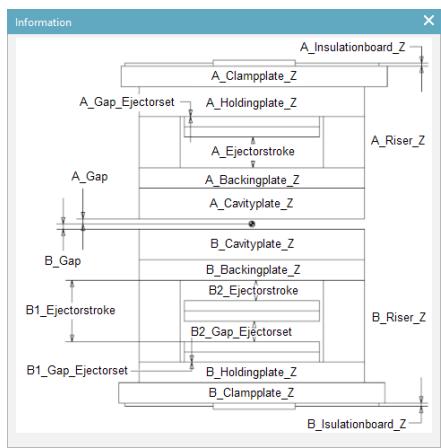

Meusburger

Meusburger

Hasco

Sondergroessen

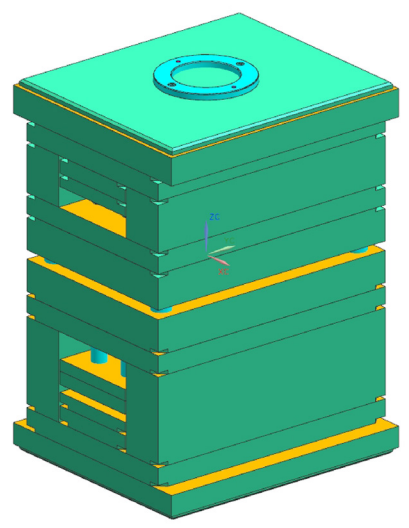

Full ordering information is passed to the bill of material

Bill of Material

Select Components

Select Components (0)

List

Pos	QTY	Description	Catalog	Material	Supplier	Partname	
1	1001	1	clampingplate	K10/396 x546x36/1730	1.1730	Hasco	12345_2_1001
2	1002	1	holdingplate	K30/396 x546x56/1730	1.1730	Hasco	12345_2_1002
3	1003	1	riser				
4	1004	1	riser				
5	1008	1	ejector_baseplate				
6	1007	1	ejector_holdingplate				
7	1009	1	backingplate				
8	1010	1	cavityplate				
9	1011	1	cavityplate				
10	1012	1	backingplate				
11	1013	1	riser				
12	1014	1	riser				
13	1017	1	ejectorset_baseplate				
14	1018	1	ejectorset_holdingplate				
15	1021	1	holdingplate				
16	1022	1	clampingplate				
17	1302	1	isolationplate				
18	1301	1	isolationplate				

Bill of Material

Select Components

Select Components (0)

List

Pos	QTY	Description	Catalog	Material	Supplier	Partname	
1	1001	1	clampingplate	F10/396 546/36/1730	1.1730	Meusburger	12345_2_1001
2	1002	1	holdingplate	F60/396 546/56/1730	1.1730	Meusburger	12345_2_1002
3	1003	1	riser	F70/396 546/86/96/1730	1.1730	Meusburger	12345_2_1003
4	1004	1	riser	F70/396 546/86/96/1730	1.1730	Meusburger	12345_2_1004
5	1008	1	ejector_baseplate	F85/396 546/218/27/2312	1.2312	Meusburger	12345_2_1007
6	1007	1	ejector_holdingplate	F80/396 546/218/22/1730	1.1730	Meusburger	12345_2_1008
7	1009	1	backingplate	F60/396 546/56/1730	1.1730	Meusburger	12345_2_1009
8	1010	1	cavityplate	F50/396 546/22/2312	1.2312	Meusburger	12345_2_1010
9	1011	1	cavityplate	F50/396 546/22/2312	1.2312	Meusburger	12345_2_1011
10	1012	1	backingplate	F60/396 546/56/1730	1.1730	Meusburger	12345_2_1012
11	1013	1	riser	F70/396 546/86/96/1730	1.1730	Meusburger	12345_2_1013
12	1014	1	riser	F70/396 546/86/96/1730	1.1730	Meusburger	12345_2_1014
13	1017	1	ejectorset_baseplate	F85/396 546/218/27/2312	1.2312	Meusburger	12345_2_1017
14	1018	1	ejectorset_holdingplate	F80/396 546/218/22/1730	1.1730	Meusburger	12345_2_1018
15	1021	1	holdingplate	F60/396 546/56/1730	1.1730	Meusburger	12345_2_1021
16	1022	1	clampingplate	F10/396 546/36/1730	1.1730	Meusburger	12345_2_1022
17	1302	1	isolationplate			Brandenburger	12345_2_1301
18	1301	1	isolationplate			Brandenburger	12345_2_1302

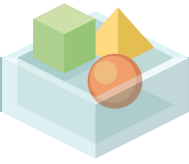

Modify supplier, shape and size changing parameters in standard part dialogue window.

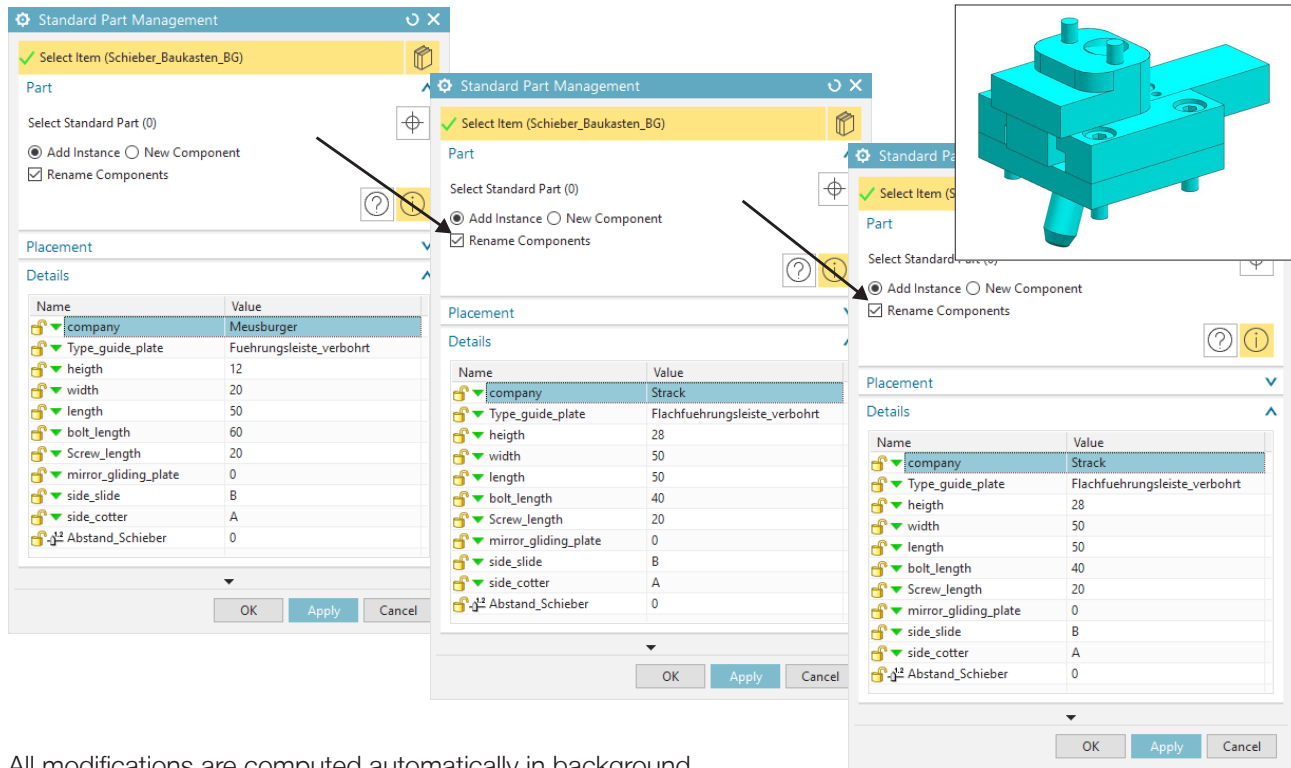

All modifications are computed automatically in background without need to delete, rework, re-insert and re-position by the user - at any time in mould design.

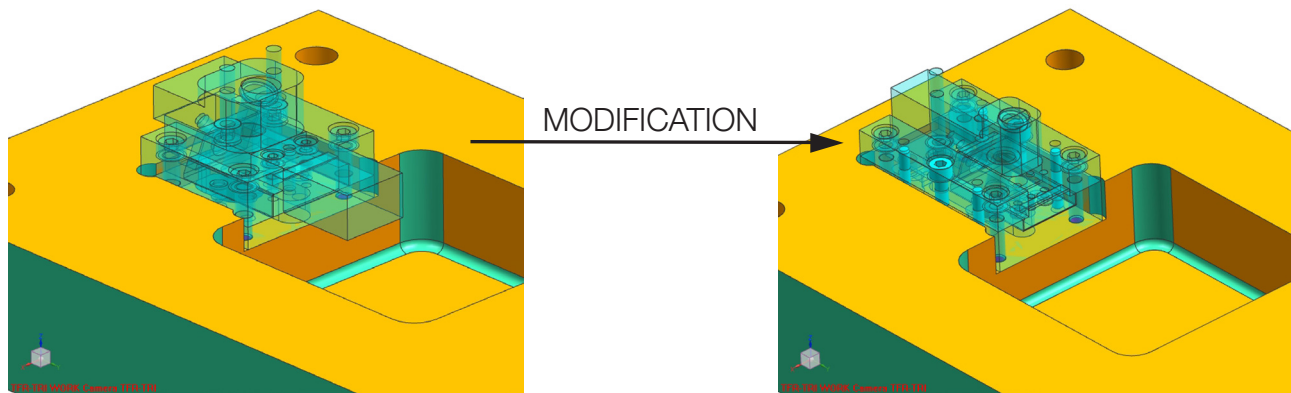

Standard part's manufacturing information (pocket body) completely associative

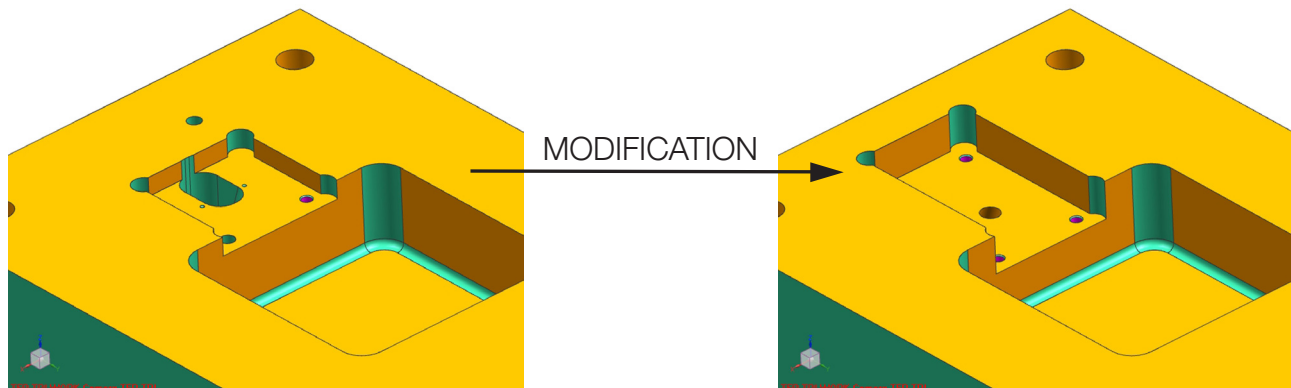

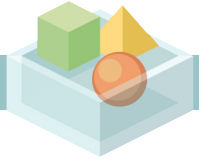

➤➤ Benefits and advantages by using colour codes for manufacturing

Colour Table

Face Quality	Colour	Tolerance
fitting surface / fitting	Yellow	± 0.01 mm
cold-runner, O-ring face, etc.	Green	± 0.05 mm
clearance faces / hole	Cyan	± 0.20 mm
tap drill hole / thread core hole	Magenta	± 0.10 mm
cooling and counter bore/sink	Blue	± 0.10 mm

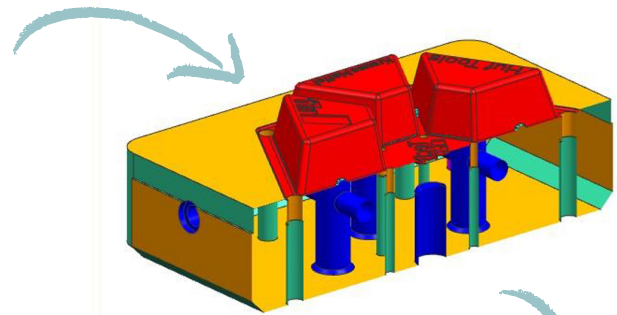

Time saving:

Production inquiry based on 3D / without drawing is possible

Reducing design time by omitting drawings

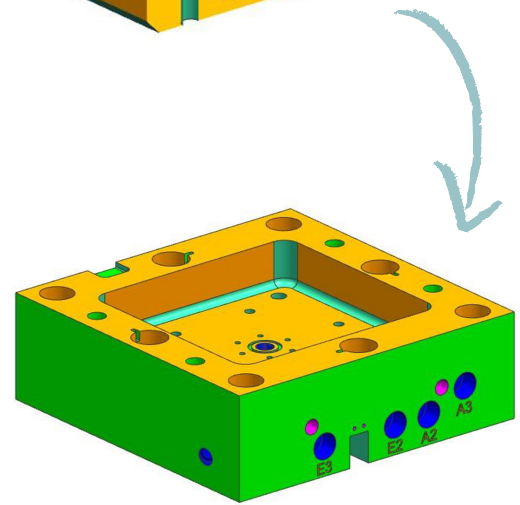

Interpretation:

Quick and precise recognition manufacturing requirements

Recognition of manufacturing requirements on each single part possible, independent from further assembly components

Standardisation:

Colour information may be passed over to neutral formats like STEP, IGES and JT.

Colours work international and cross-language

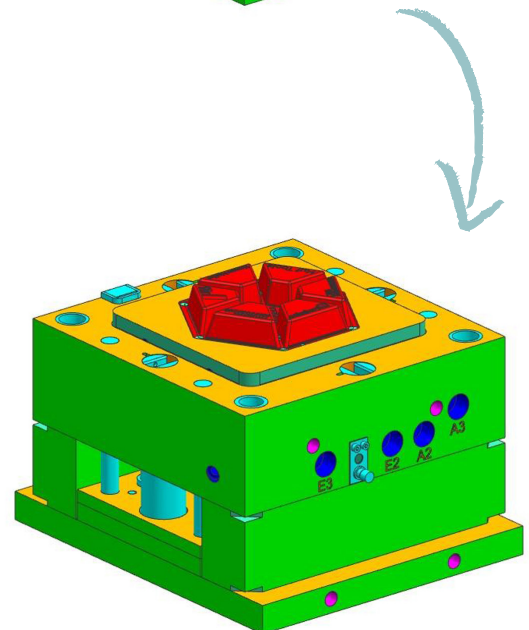

Further advantage:

Safety in design and fault reduction

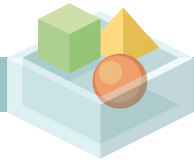

At a glance

Mold Wizard standard:

Colours to distinguish plates from each other

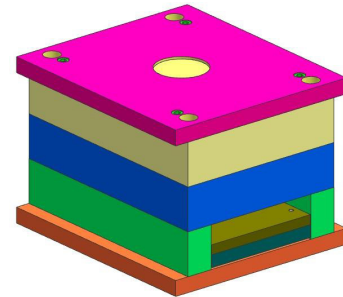

Mold Wizard with NT App standard parts:

Easy to determine manufacturing tolerances by applying a clear set of colours

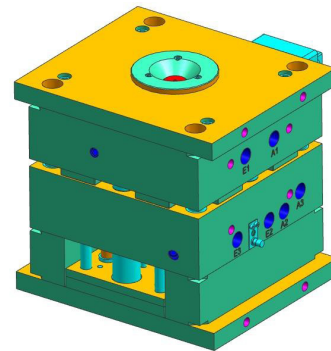

Colours:

Recognise manufacturing tolerances by face colours

Face Quality	Colour	Tolerance
fitting surface / fitting	Yellow	±0.01 mm
cold-runner, O-ring face, etc.	Green	±0.05 mm
clearance face / hole	Cyan	±0.20 mm
tap drill hole / thread core hole	Magenta	±0.10 mm
cooling and counter bore/sink	Blue	±0.10 mm

Standard parts:

Select a standard part and chose between mutiple suppliers

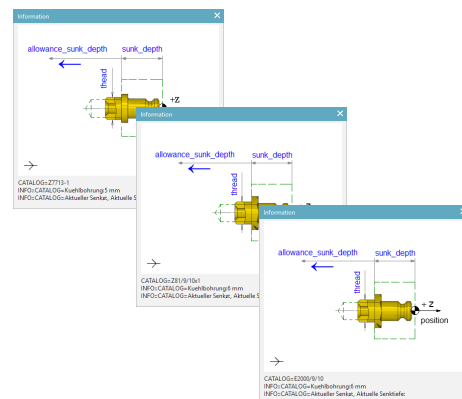
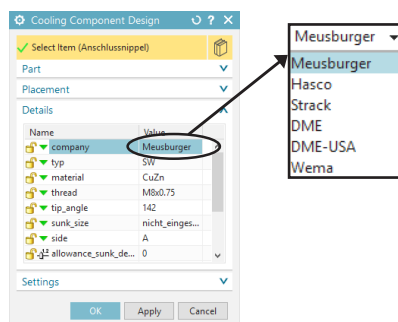

Bill of Material:

All information necessary for ordering process is attached to the parts and is updated upon change automatically.

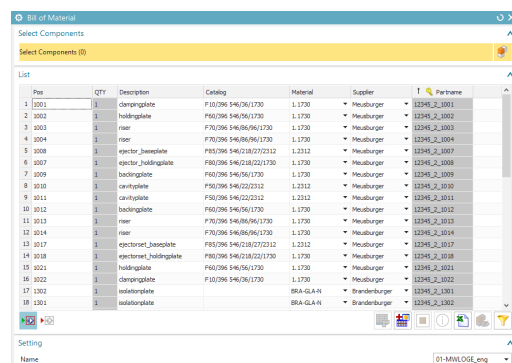

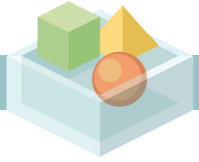

Impressum

CIMTEC GmbH
Ringstraße 5
96269 Großheirath
Germany

Tel.: +49 9565 9460-0
Fax: +49 9565 9460-19
www.cimtec.de



References



BOSCH

HaidlMair

PRODRIVE
TECHNOLOGIES

GAUDLITZ[®]
PLASTIC
TECHNOLOGIES

HOFMANN
IHR MÖGLICHMACHER

Rauschert

GIRA

HOFMANN
IHR IMPULSGEBER

WP
innovative packaging

The database was developed with support from the standard part manufacturers

HASCO[®]



meusbürger[®]

KNARR[®]

STRACK[®]
NORMALIEN

CIMTEC GmbH

Ringstraße 5
D-96269 Großheirath

Tel.: +49 9565 9460-0
Fax: +49 9565 9460-19
www.cimtec.de