

Gasdruckfedern MICROserie

Gas springs MICROseries

Ressorts à gaz MICROsérie

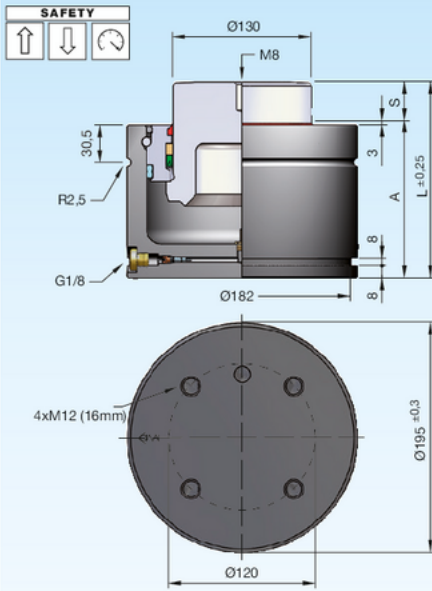

Einbauvarianten / Installation variants / Variantes de montage

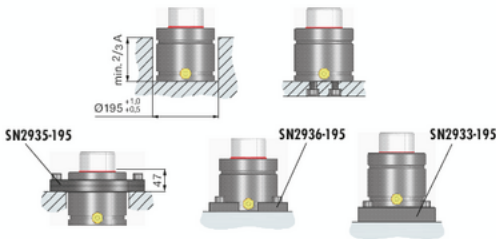

Druckmedium	Pressure medium	Médium de pression	Stickstoff (N ₂)
Max. Fülldruck	Max. filling pressure	Pression de rempl. max.	150 bar
Min. Fülldruck	Min. filling pressure	Pression de rempl. min.	35 bar
Max. Betriebs-temperatur	Max. working temperature	Température de service max.	80 °C
Temperaturabhängige Druckerhöhung	Pressure increase due to temperature	Accroissement de pression sous l'influence de la temp.	0,33 %/1 °C
Instandhaltungssatz	Maintenance kit	Jeu de maintenance	SN2990-M195
Max. Kolbengeschwindigkeit	Max. piston speed	Vitesse max. du piston	1 m/s

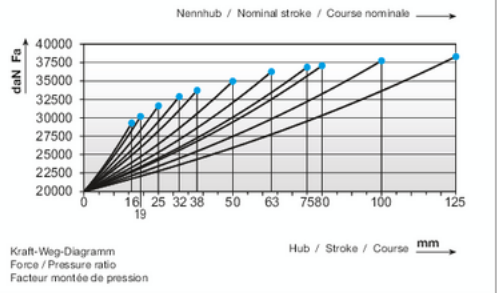
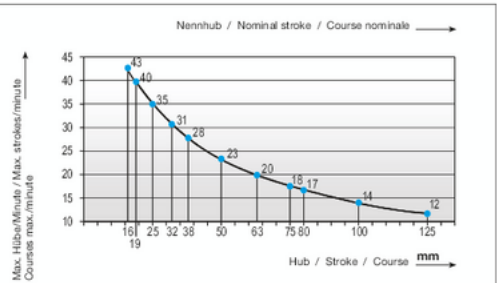

SN2808-20000-



SN2808-20000-S



S = Hub / Stroke / Course

bar = Fülldruck / Filling pressure / Pression de remplissage

S	daN	daN	bar	A	L	V [l]	Fa [cm ²]	kg
16	20000	29645	150	126	142	0,647	132,73	20,85
19	(±5%)	30540	150	129	148	0,725	132,73	21,45
25		31960	150	135	160	0,880	132,73	22,10
32		33190	150	142	174	1,061	132,73	22,85
38		34005	150	148	186	1,217	132,73	23,45
50		35200	150	160	210	1,528	132,73	24,70
63		36095	150	173	236	1,865	132,73	26,10
75		36700	150	185	260	2,176	132,73	27,25
80		36910	150	190	270	2,305	132,73	28,20
100		37570	150	210	310	2,824	132,73	31,10
125		38135	150	235	360	3,472	132,73	35,20