

Gasdruckfedern kleine Abmessungen

Gas springs small dimensions

Ressorts à gaz dimensions petites

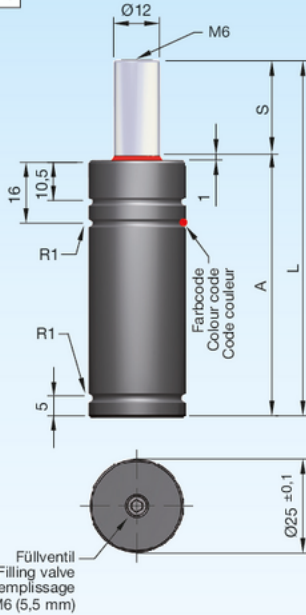

Einbauvarianten / Installation variants / Variantes de montage

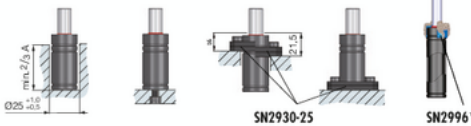

Druckmedium	Pressure medium	Médium de pression	Stickstoff (N ₂)
Max. Fülldruck	Max. filling pressure	Pression de rempl. max.	175 bar
Min. Fülldruck	Min. filling pressure	Pression de rempl. min.	25 bar
Max. Betriebs-temperatur	Max. working temperature	Température de service max.	80 °C
Temperaturabhängige Druckerhöhung	Pressure increase due to temperature	Accroissement de pression sous l'influence de la temp.	0,33 %/1 °C
Instandhaltungsset	Maintenance kit	Jeu de maintenance	SN2990-G25
Max. Kolbengeschwindigkeit	Max. piston speed	Vitesse max. du piston	1,6 m/s

3

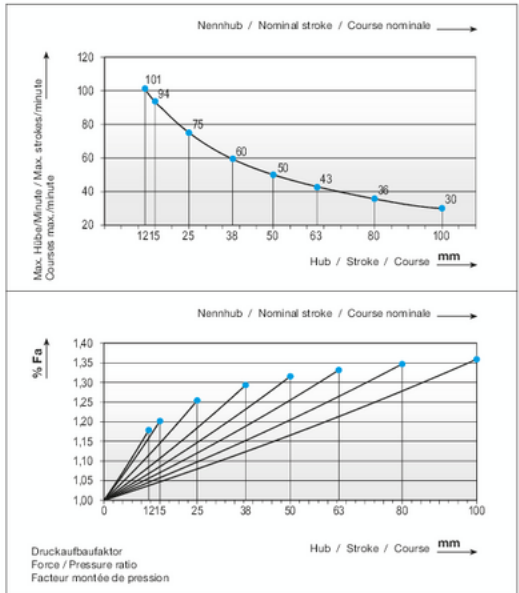

SN2805-25-200-		S	Type	A	L	V [l]	Fa [cm ²]	kg	
 SN2805-25-200-S-Type	 S = Hub / Stroke / Course bar = Fülldruck / Filling pressure / Pression de remplissage	12	1	66	78	0,009	1,13	0,16	
		15	2	69	84	0,010	1,13	0,17	
		25	3	79	104	0,014	1,13	0,18	
		38	4	92	130	0,019	1,13	0,22	
		50		104	154	0,024	1,13	0,25	
		63		117	180	0,029	1,13	0,26	
Type Farbcode Colour code Code couleur	 daN	 daN	bar	80	134	214	0,035	1,13	0,28
				100	154	254	0,043	1,13	0,32
				1	Grün / Green / Vert	50 (-5)	70	45	
				2	Blau / Blue / Bleu	100 (-5)	140	90	
3	Rot / Red / Rouge	150 (-5)	210	135					
4	Gelb / Yellow / Jaune	200 (-5)	270	175					
Andere Kräfte / Other forces / Autres forces		28-200	≈40-270	25-175					

i SN2996* = Seite / Page 2.3.254