

Interesting facts for the tool- and mould making

Editorial



We are starting the year 2015 with a highlight and present the elements of the BreyLine construction kit for the universal clamping solution. Read in our cover story how we include the flexible system FCS as holistic processing philosophy in our PowerMax® production and convince yourself of the benefits.

From this year we are also newly set up "online". The variable design of mould assemblies and die sets, which you can flexibly combine within the Webshop, is just one of the novelties. In addition we present our updated site for the PowerMax®. Under www.strack.de you find from now on all data and figures concerning the success models of the standard cam.

Since the beginning of the year, we are again a pure family business. We are proud that we could take over on 1st January 2015 the 49 % which were still held by the French company Rabourdin. Due to the structure as a pure family business we achieved a high degree of flexibility and independence. Thus we are strategically excellently equipped for the future. This is also reflected by our new developments and program extensions, which you can find in the inner part.

Have fun while reading!

Dag Friedrich
Managing Director



The elements of the BreyLine construction kit of FCS systems allow a five-side machining poor of interfering contours.

Exiting highlight

The clamping technology of FCS is not only be distributed but also used

The PowerMax® cams of STRACK NORMA which are in particular very successful in large tools of the automotive industry create their own challenges for the setting-up in the production. Due to the fact that the philosophy of the clamping technology experts of FCS fits very well in the own company, the cutting machine operators at STRACK not only use but also distribute the system.

"The cams of the PowerMax® series are partly very complex and are delivered ready to be installed – the user can be confident by one hundred percent that they can be fitted as planned and that they are working reliably", explains Ludger Müller, Manager of Technology and Development at STRACK NORMA. "This means that we have to produce its components very precisely and correspondingly with high quality". For this purpose, among other things, powerful 5-axis machine centers from the company DMG Mori are available for the cutting machine operators.

Reduce non-productive times

A major cost factor in the chipping is the non-productive times. The set-up times and exposure times often extend the cycles of the work pieces to a multiple of the actual machining time. Possibly a set-up

operation blocks precious machine time, the staff costs quite apart. The planners of the production process preparation of STRACK NORMA have already been aware of this problem for a longer time. Especially in more complicated clamping situations too much time was lost, the setter decided on-site about the set-up situation and compiled then the necessary clamping devices.

"While at the processing of plates the clamping challenges are very clear, the PowerMax® components have relatively complex machining situations with the correspondingly demanding work piece clamping", explains Müller.

"With conventional clamping devices the



The cams of the PowerMax® series are particularly used in tools of the automotive industry.

machining of these work pieces could not be further optimized reasonably. Moreover the cost pressure from the competitors is constantly increasing. Thus, we began searching for a modular standardized clamping solution being able to clamp our products fast, easily and process-reliably." Here the responsible persons involved all persons concerned to ensure from the very beginning a high level of acceptance for the jointly developed solution.

Universal clamping solution

Many producers are meanwhile offering modular clamping solutions. For STRACK NORMA it was important to find a clamping solution for the PowerMax® production, but also to find a flexible customer solution for the mould plate clamping.

"We were looking for a system with reference point in the guide drilling", emphasizes Müller "An island-solution was out of question for us. We wanted a system offering a high degree of flexibility for each tool construction which doesn't want to be determined in its clamping possibility on only one standard part producer. The standard part specialist found the solution at the Italian producer FCS-System. Its Breylline clamping system works with a fixed zero point in the guide drilling of the base plate. On a 50s grid nearly all desired clamping positions can be realized with moveable clamping devices without requiring additional elements.

The modules can be combined flexibly and thus enable optimized clamping positions.

Bores directly placed into the work piece in which the clamping spigots of the system are inserted, provide, despite of the filigree looking, for the process-reliable hold also at more robust machining. The forces are not transferred over the screw-connections; the very precise form fit allows a high stability.

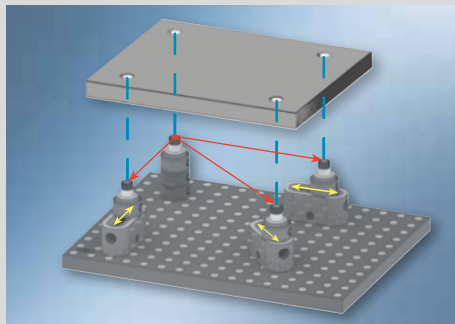

Flexible Formplattenspannung mit FCS auf Spann-tisch mit 50er-Raster.

Bores with added value

"Even if the insertion of bores firstly appears as an additional step- the effort is worthwhile", Müller is convinced. "A special software for production planning shows among other things, where the required boring for the clamping spigots can be positioned. A side-effect of this more extensive planning is that process steps can be optimally planned from a holistic perspective."

Thus it is also ensured that in the decisive moment all necessary materials, tools and clamping elements are available. In many cases this requires that the processes are turned topsy-turvy.

"It is not enough to reproduce the previous clamping situation" emphasizes Müller. "The advantage which arises simply due to modularity of the construction kit is not the essential thing. The far greater potential for optimization lies in the fact to exhaust the possibilities of the clamping system consequently and to optimize the production processes.

Exhaust possibilities

Thus the possibilities of 5-side-machining can be used with the clamping elements- a position of the component which is elevated from the clamping table, allows to machine without interference contours. The permanent reference points create a high flexibility - thus it is no problems to declamp a part and to clamp it again several times on different pallets or other machine tables. The zero point is maintained, even in later modifications and part repairs: the bores allow a fast clamping, the repeatability is 3µm.

"We are only at the beginning of the optimization of our production", explains Müller. "Nevertheless already now progresses can be noticed - our set-up times are considerably reduced and decoupled from the machines. Often we can replace several clampings with a single one. This, what we are now working for in the production for the PowerMax® cams, we will implement bit by bit also in the other sectors of our production. We are so convinced by this production philosophy that we have added the FCS clamping system meanwhile to our own sales program. ■

New limit switches from the company STRACK

Product range expansion in proven quality

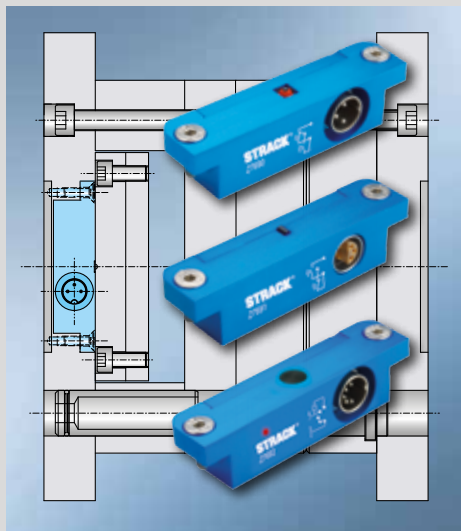

The standard part specialist STRACK NORMA has extended its limit switch program. In addition to the proven program, the new series is based on a change of the housing design. The complete insertion for the limit switch can now be done exclusively through the vertical spindle axis. Related to practice this has a more positive effect on the production. In the tool- and mould making the limit switches find diverse applications. They pass monitoring functions and launching signals to the machine control. These signals are generated by mechanical or inductive (touch-less) switches.

The new housing design is available parallel to the classics of the STRACK-limit switches, in the types Z 7690 as mechanical limit switch up to 120°C, Z 7691 as mechanical

limit switch up to 240°C and Z 7692 as inductive limit switch which can be used up to 100° C.

The STRACK limit switches are among other things used at the path-dependent operation of additional functions. Also the securing of ejector sets, stripper plates, core pulls and slides is task of the limit switches, so that there is a safe solution for each monitoring. The aluminium housings present themselves in the corporate-design-colour of the company and are mostly spray-water protected according to IP66.

An extensive accessory program of connecting cables and distribution boxes completes the program and thus significantly contributes to safe production processes. ■

The construction tip

Easily replaced

Great cost savings due to the fact that in case of wear only the sintered metal strips have to be exchanged



Prismatic guides are particularly used for the guiding of self-designed cams in large tools, where the sliding piece is usually made out of bronze with solid lubricant and the prismatic counter bearing out of surface-hardened steel. The complete sliding piece out of bronze has to be replaced when worn.

The company STRACK NORMA offers now a sliding piece SN 3886 made of tempered steel which running surfaces are planked with sintered metal guide strips SN 3886-VLS.

In case of wear the complete slide piece must no longer be replaced, but only the sintered metal guide strips, resulting in significant cost savings. Moreover it was determined in various tests in the automotive industry that the service life of sintered metal is many times higher than that of bronze with solid lubricant.

The dimensions of the sliding pieces out of steel with the planked sintered metal guide strips, offered by STRACK since

the beginning of this year, correspond to VDI 3357 and are thus identical with the bronze sliding pieces, so that they can easily be replaced in the existing tools in case of wear.

For absorption of side forces the sintered metal guide strips are shouldered in the base body with fitting keys in both directions. The SNS-sintered metal guide strips are identical for the right and the left side and can be exchanged. ■

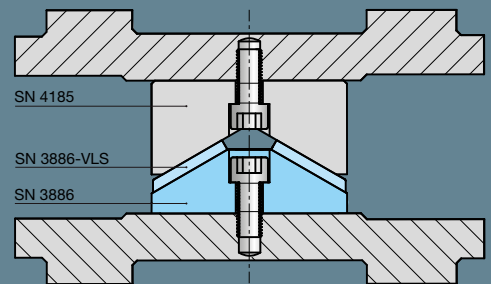
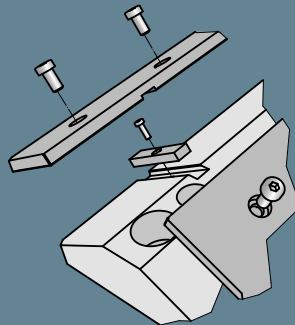

A round thing

Cylindrical design provides for high position accuracy

With a novelty in the area of centering units the standard part producer STRACK NORMA draws the attention to itself: the new flat centering unit Z 49 with cylindrical outer contour.

Usually the guidance of the tool is effected by guide pillars and guide bushes. However at modern and high-precision tools it has become essential to guide the mould halves even more precisely to prevent an offset of the mould contour and to increase the part quality. So, the pairing of pillars and bushes requires a clearance fit due to the warming in the tool. If this not happens an increased clamping behavior would be the result. This clearance fit requires the use of a fine centering.

The centering unit is offered in different dimensions to be able to absorb the forces for the different mould sizes respectively. The positioning in the tool is done via centerlines or diagonals to compensate different

thermal expansions in the two mould halves. The screwing of the centering units can optionally be done from the parting plane or the back side. To guarantee resistance torsion of the centering units, the lateral pin holes or alternatively those in the bearing surface which are intended for this purpose have to be used.

Compared to the already usual fine centerings in flat design, the round version has enormous advantages for the practical insertion of the machining in the tool. The boring can be spindled and thus has a higher position accuracy in the tool. Moreover compared to the milled retainers, the spindled retainers have the advantage that they can be produced faster and have a price advantage.

With this STRACK novelty we offer you another possibility to center the two mould halves of injection moulds precisely and inexpensively. ■

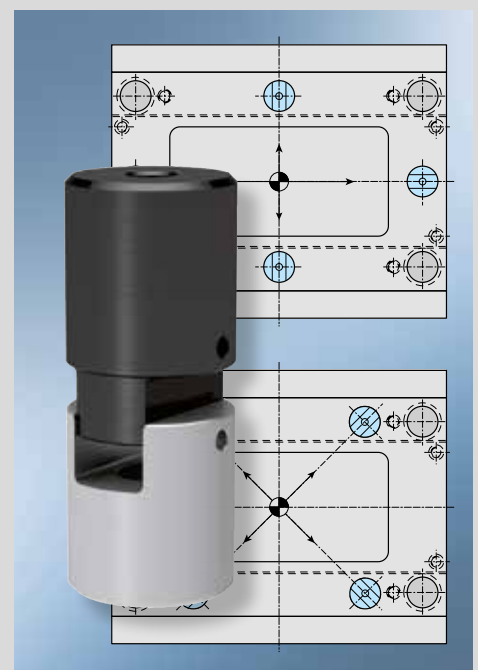

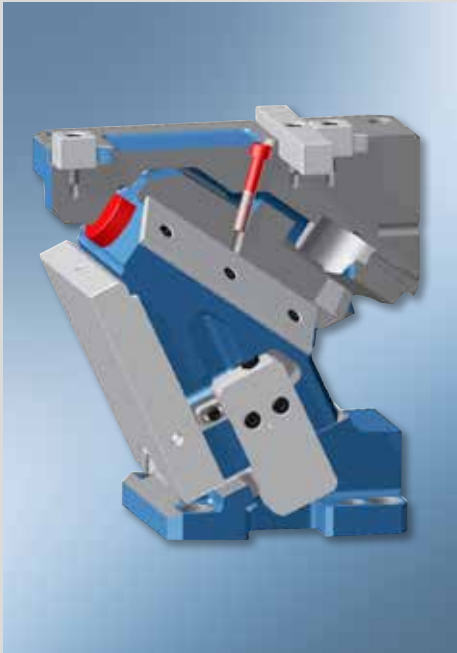

More performance at the cam program

STRACK offers two Lock-Out-Systems as standard

On the market STRACK NORMA is one of the leading providers of standard cams in the stamping- and forming technology. The success model series of the company is the cam program PowerMax® which is the only one offering three variants. The homepage www.powermax-schieber.de has now been integrated in the online offer of the company homepage. As the company communicates, the contents on the Special-Interest-Site are no longer maintained.

From now on company customers will find all data and facts concerning the product series under www.strack.de. The

functioning of the cams which realize in tools lateral punching-, cutting- and bending operations, is illustrated. In addition to the CAD data necessary for the construction, the users will find accessories and spare parts which can directly be ordered online.

A novelty is undoubtedly the patented Lock-Out-System SN 5654 with which the complete cam program was equipped. The system creates the possibility to fix the respective cam during the machining. Thereby the defined guide play is avoided and allows a precise machining in narrow tolerance ranges. ■

Combine comfortable - Now variable mould constructions and die sets in the webshop

Online planning allows quick calculation and construction



For die sets various parameters and features can be combined individually. For example, the type and adjustment of the work surface, the number of the plates, the type of the guiding elements and their kind of fixation. For the respective application the required plate dimension as well as a large selection from the resulting sliding- or ball-guide elements is considered. Thus, on

the computer, a practical design is created by the intuitive and simple selection of the components.

Only with just a few mouse-clicks, a variety of combinations allows the creation of special constructions, differing from the common standard constructions. ■

Since November STRACK NORMA has now integrated the customer-specific design of mould constructions and die sets in its webshop. By doing this, the standard part specialist has complemented its comprehensive online-offering by an important element. No matter whether a punch-/bending tool, an individual mould construction, a mounting device or a feeding unit, the STRACK program offers as usual flexible and precise solutions. For tool constructions and –calculations the provided CAD data and part lists create a reliable basis.

From now on, customers can combine, directly via the homepage just in a few steps, a large number of guiding elements and plates to compile an individual die set or a demand-oriented mould construction for the required application.



The “Ironman” retires

At the age of 65 years Reinhold Spielberger changes from the standard part to the bike

After more than 22 years in the “world of the standard parts” Reinhold Spielberger who, in addition to his job, is an enthusiastic triathlete, goes in the earned retirement.

After his training as industrial clerk, the following A-levels and studies to become an industrial specialist, Reinhold Spielberger joined the company STRACK at the beginning of October 1992. He started as head of the department for stamping- and forming technology which at that time was still in its early steps, later he took additionally over the management of the department of purchasing and development for the punching range. In the year 2000 he became the first Key-Account-Manager at STRACK and was henceforth responsible for the support of major customers, primarily from the automotive industry. Initially he was only concentrated on low-maintenance sliding elements, over the time the range of gas springs and finally the cam-series PowerMax® were added – all “his babies”.

“The relationship to the customer combined with competence, expert knowledge and honesty are the most important thing in this job. Nowadays you have to be authentic and must be able to listen to attract and retain customers”, Spielberger points out.

Reinhold Spielberger is decisively involved in the introduction and the start of the in-house production of the standard part cam PowerMax®, which is produced at the site Lüdenscheid since 2008. He introduced these cams at first in the German automotive industry and later worldwide. Meanwhile the PowerMax® is one of the most successful products of STRACK NORMA. “The customer must be able to rely on us. We are reaching this with punctuality, commitment and quality. Also the personal connection to the customer is important”, Spielberger is sure. “Also after my time at STRACK I maintain contact to one or another customer”.

In the time after STRACK, the native Hessian will dedicate to his long-time dream to explore

the world by bike. In a two-week “practical course” he will learn in a workshop of a friend the basics of the bicycle construction before he starts in the middle of May for about 4 months with the first stage of his tour.

From his hometown Wuppertal he drives over Berlin to Poland- until here he will be accompanied by his wife. From Gdansk he will go alone to the Masurian Lake District over the Baltic States to Riga, Tallin and Helsinki.

Along the Russian border he “rides” to the North Cape; from here to Norway, Sweden and Denmark. From Denmark he returns back to Wuppertal. “I will spend the nights in guest-houses and cottages. In times of need I also have a tent and a sleeping back in the luggage”, he tells. At the latest in mid-September Spielberger wants to be back in Wuppertal, because then the next Cross-Triathlon takes place in which organization he is involved and in which he is of course actively participating. During the winter months he plans then the second stage of his bicycle tour which should start 2016 in direction Southern Europe.

Reinhold Spielberger passes its customers to the proven STRACK-Key-Account-Team Markus Steinhilber, Roberto Inchingoli and Daniel Brockhaus. The mechanical engineer Markus Steinhilber joined STRACK NORMA in 2012 and is now taking over the entire area

South Germany, which he is partly already looking after at the moment.

In addition to him also Roberto Inchingoli is the new contact person in the range of PowerMax®. The today 23-years old Inchingoli which joined the company 2007 as trainee is now responsible for the area Northern Germany. Together with Markus Steinhilber he coordinates the foreign representations in this range. “I am looking forward to new tasks and the cooperation with the customers”, Inchingoli points out, who uses the first months of his activity to present himself to all customers.

Daniel Brockhaus, who completed his studies as industrial engineer with success in 2013 and has worked since then for the company, will support the team from the office.

Looking back to his career at STRACK, Spielberger estimates the trust the company placed in him. “I was always able to move freely and thus I could introduce new ideas and realize them. I didn’t have to keep predefined paths and was free to be able to look further than one’s plate. All this motivated me again and again and led to successful results.” He wishes that his successors continue having the fun and the commitment at work which they have already shown in the two-years-training period and the common projects. “Just go ahead” Spielberger demands with a wink. ■



Reinhold Spielberger at one of his triathlons on the Spanish island Mallorca.

STRACK Key-Account-Team:



Roberto Inchingoli
Key-Account

Tel.: +49 2351 8701 142
Fax: +49 2351 8701 222
E-Mail: r.inchingoli@strack.de



Markus Steinhilber
Key-Account

Tel.: +49 2351 8701 211
Fax: +49 2351 8701 222
E-Mail: m.steinhilber@strack.de



Daniel Brockhaus
Key Account - Backoffice

Tel.: +49 2351 8701 193
Fax: +49 2351 8701 222
E-Mail: d.brockhaus@strack.de

STRACK NORMA is again a purely family-owned company

Andreas Geyer and Bettina Kümmel are sole shareholders



The standard part specialist STRACK NORMA GmbH & Co. KG is again a purely family-owned company. Andreas Geyer and his sister Bettina Kümmel acquired the 49 % of the shares still held by the French company Rabourdin with effect from the 1st January 2015. Already 5 years ago the family Geyer had gained the majority in the company by acquiring shares.

In the 1920s, the great-grandfather Ewald Geyer founded the tool making with the same name in Lüdenscheid. A few years later Friedrich Strack took over representations for machine tools and die-sets. After many years of successful cooperation of both companies the takeover of the STRACK-Group by Geyer & Co. was carried out in 1981. In 1996 the French standard part provider Rabourdin participated in the German market competitor and held temporarily up to 74,5 % of the shares.

Together with the managing director Dag Friedrich and the Commercial Manager

Michael Lang, Andreas Geyer looks positively into the future: „STRACK NORMA is excellently positioned and all strategic decisions can be taken in-house“, Andreas Geyer states. The fourth generation of the family is already in the „starting blocks“ to continue the family tradition.

The company STRACK NORMA is a producer and supplier of parts for the tool- and mould making. Customers` requirements increasingly shape the product portfolio of the company based in Lüdenscheid. High-quality special solutions result in technically innovative products that are also finding their way in the standard.

Currently the company has about 150 employees at the site Lüdenscheid. In addition it maintains a worldwide distribution network with 13 sales offices in Germany and more than 30 sales offices abroad. ■



Masthead

The "Normalien Report" is an information service of STRACK NORMA GmbH & Co. KG
Königsberger Str. 11
58511 Lüdenscheid
Tel.: +49 2351 8701-0
Fax: +49 2351 8701-100
www.strack.de

Conception, text and layout:
STRACK NORMA GmbH & Co. KG

References:
Cover story by Richard Pergler,
Trade journal „Werkzeug & Formenbau“

Trade shows 2015

The fair season for STRACK NORMA begins in spring. In May the first of totally 4 inland fairs in this year will take place. The Moulding Export in Stuttgart, the new international trade fair for the tool-, model- and mould making will take place from 5th to 8th of May 2015 on the exhibition grounds in Stuttgart. STRACK presents itself in hall 6 booth D91.

Only a few weeks later on 17th and 18th of June, the standard part specialist exposes its product highlights on the wfb fair, the trade fair for the tool- and mould making in the "Siegerlandhalle" in Siegen. Here you will find STRACK at the booth S-70.

In the second half of the year we will go to the fair FAKUMA in Friedrichshafen and to the fair Blechexpo in Stuttgart.

Discover numerous novelties and innovations. STRACK is looking forward to your visit!



5-8 May 2015
Messe Stuttgart / Germany



17-18 June 2015
Siegerlandhalle Siegen / Germany

Anniversaries

Congratulations!

STRACK congratulates the employee belonging to STRACK family for 10 years

Frank Tettenborn January 2005

and the employee belonging to the STRACK family for 25 years

Volker Agel April 1990