

**CAM UNIT
PMO-V04
OPERATING INSTRUCTIONS
STAND 09.2022**

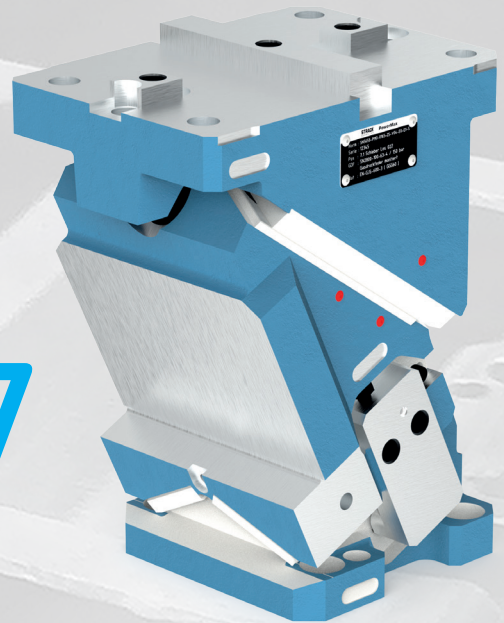

PowerMax[®] 2.0
the next generation



STRACK[®]

NORMALIEN

Contents:	Page:
Preamble	4
1. Safety instructions. Please absolutely consider!	5
2. After receipt of delivery	6
3. Features	7
3.1 Description of the designs	8
4. Scope of delivery	8
5. Design of the PowerMax side cams	9
6. Preparation of tool and press	10
7. Shouldering	10
7.1. Centering in the tool by means of dowel pins and/or slot nuts	11
7.1.1 Dowel pin (old „Z“)	11
7.1.2 Slot nuts LONG + CROSS (old „N“)	12
7.1.3 Slot nut CROSS + dowel pin	12
7.1.4 Slot nut LONG + dowel pin	12
8. Production	13
8.1 Handling with safety ring bolt (SN1594)	14
8.1.1 Mounting of the cam slide in the cam retainer	14
8.1.2 Mounting of the cam slide with cam retainer in the upper part of the tool with central transport thread	14
8.1.3 Mounting of the cam slide with cam retainer in the upper part of the tool with lateral transport thread	14
9. Marking of the cams	15
9.1 Information concerning Lock-Out-System SN5654-LOS	21
10. Disassembly / assembly / of the gas spring	22
10.1 Cam lock	22
11. Modification of the system pressure of the gas springs	23
11.1 Releasing of the pressure at a gas spring	23
11.2 Increasing of the pressure / filling of a gas spring	24
12. Standstill and storage	26
13. Maintenance	26
13.1 Pre-adjustment of the active return	27
13.2 Adjustment of the forced return	29
14. Appendix	32
14.1 Internet and CAD	32
14.2 Lubricant Z9084	23
14.3 Limit switch Z7685	34
14.4 General description gas springs	35

Contents:		Page:
14.6	Calculations gas springs	37
14.7	Installation instructions gas springs	38
15.	Exploded view and parts list	42

PowerMax cam unit SN5650-PMO-0330 — SN5650-PMO-1200

Preamble

Thank you for your confidence in the product of STRACK NORMA GmbH & Co. KG.

We are pleased that you have chosen a product of STRACK. To facilitate your handling of the product, we prepared these operating instructions.

This operating manual is an important document for the side cam unit SN5650-PMO and serves for the safe and efficient operation. It is intended for all persons handling this cam-unit or for persons being responsible for its safe operation

For reasons of operational safety, a copy of these operating instructions must be left at the machine with the side cam unit to ensure direct access for the operating staff.

The safety instructions in this operating instruction have to be particularly observed to recognize and to avoid possible dangers. Read the operating instruction carefully and completely before mounting and starting-up the cam unit SN5650.

A regular maintenance is necessary to ensure a safe and economic use.

If the regulations and notes of these operating instructions are not considered, any liability on our part for resulting damages and loss of performance is excluded.

PowerMax cam unit SN5650-PMO-0330 — SN5650-PMO-1200

1. Safety instructions. Please absolutely observe!

Please absolutely read and observe the following safety instructions before mounting and starting-up and all further works at the STRACK PowerMax cam.

The cam must be used according to this operating instruction. When a new operating instruction is published, this version loses its validity.

Service and maintenance work at mounted STRACK nitrogen gas springs may only be effected by persons trained and instructed by STRACK NORMA with good technical knowledge.

If the mounted STRACK nitrogen gas spring is used improperly or for purposes other than those for which it is intended there is a risk of:

Dangers to health,

Danger to the STRACK nitrogen gas springs and other assets of the user,

Danger to the efficiency of the STRACK nitrogen gas springs.

For all work at the STRACK side cam the valid industrial safety ordinance, section 3, must be observed.

Press, tool, and peripheral devices must be suitable, prepared and coordinated for the use of STRACK side cams.



Attention:

There is the risk of accident before and during the service- and maintenance works at the tool or the STRACK cam. For this reason, these works may exclusively be carried out at retracted side cam units.

Jammed cam unit can lead to abrupt relaxation with intact gas springs and can thus be a risk of injury.

Damaged gas springs must not be reused. The exchange of individual components has to be discussed with STRACK NORMA.

PowerMax cam unit SN5650-PMO-0330 — SN5650-PMO-1200

2. After receipt of delivery

Examine the delivery for external damage before opening. Immediately report any damage to the transport company, that delivered the consignment.

Compare the content of your consignment with the delivery bill or the enclosed parts list (see appendix). Ensure that all parts are present and unpacked.

Only then dispose of the transport- and packaging material.

If the contents are damaged without external damage of the packaging do not return it for repair or exchange.

Please contact STRACK NORMA GmbH & Co. KG in Lüdenscheid for further information.

CONTACT:

Team PowerMax, Automotive

Phone: 02351 / 8701 - 7300

E-Mail: team3@strack.de

PowerMax cam unit SN5650-PMO-0330 — SN5650-PMO-1200

3. Features

The design of this STRACK cam unit is a „side cam unit type SN5650“. This PowerMax cam unit consists of:

- Cam retainer
- Cam body
- Driver

with the corresponding attachments.

All PowerMax cam units are equipped with gas springs.

As pressure medium for the gas springs in this system nitrogen with a purity level $\geq 99,8$ Vol.-% is used.

Cylinder size, -number and filling pressure (different for the different cam types) determine the available restoring force.

Please consider that all PowerMax cam units are the successful result of a long development effort. The resulting technical advantages unfold optimally when the respective cam stroke is completely used during the working process, i.e., the punching-/bending operation of the cam unit should take place in the front-end position.

The complete utilization of the cam stroke allows the maximum intervention of the active return and thus the highest possible provision of retraction- or stripping forces (about 10% of the press force). At the front-end point of the cam stroke the maximum return force of the gas spring is applied. In general, the following applies: The design and the resulting values such as installation height and return forces require that the cam unit is installed in the specified front-end position.

PowerMax cam unit SN5650-PMO-0330 — SN5650-PMO-1200

3.1 Description of the designs

The cam is equipped with slide elements out of sintered material. The work surface is made of cast-iron.



Attention:

The installed gas springs serve to additionally retract the cam slide.
The working forces required for this operation are absorbed by the active return.
The manpower needed for the operation is absorbed by the active withdrawal.

4. Scope of delivery

The PowerMax cam units are delivered preassembled and adjusted with precise guide play.
The installed gas springs are delivered with the maximum filling pressure unless otherwise requested.

The working surface can already contain customer-specific machining.

All cams can also be manufactured for the processing of high-strength sheet metal, contrary to the angles shown in the catalogue in steps of 5, in all intermediate angles according to customer requirements.

Please contact us.

PowerMax cam unit SN5650-PMO-0330 — SN5650-PMO-1200

5. Design of the PowerMax side cams

STRACK NORMA PowerMax cams are manufactured with high precision.

The guides, which are ground to a tight guide play, allow highest loads. The side cam units can be loaded with the tool on the work surface. It is important to ensure that the force is applied in the centre of the work surface.

If the load is off-centre, uneven forces are exerted on the guides and cause increased wear.

Bsp.: SN5650-PMO-0230-20-E0-G0-S0

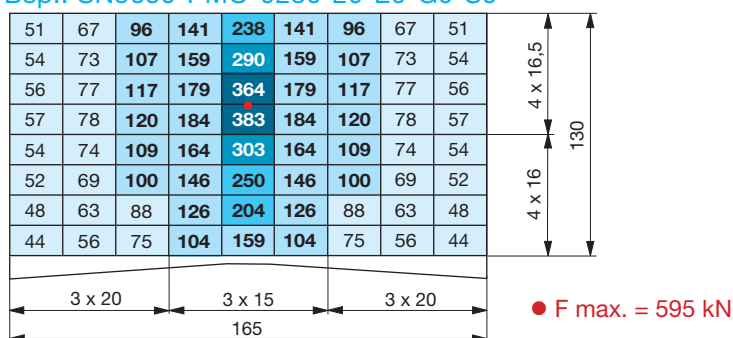

This clearly shows the maximum power outside the centre of action for the X or Y axis. Possible future changes in position should be considered in advance to select a cam size that corresponds to the force.

In order to be able to guarantee the same service life, the load forces are reduced depending on the position on the working surface.

For exact details, please refer to the catalogue information for your cam on the internet at www.strack.de



Attention:

If the cam is to be built over with attachments, a new calculation is necessary. Please contact us.

PowerMax cam unit SN5650-PMO-0330 — SN5650-PMO-1200

6. Preparation of tool and press

Tool, press and peripheral devices must be suitable, prepared and coordinated for the use of STRACK PowerMax cam units according to the specifications of STRACK.

Drain off liquid (e.g., water or drawing oil) in a targeted manner using a drainage system. Ensure that the punching waste does not fall into or onto the cam guide.

Cam slide and guide can jam. Parts falling down can damage the guides, which may reduce the service life of the cam. In case of failure the cam slide cannot be returned to its original position.

7. Shouldering

The force distribution of the individual forces in the cam depends on the right shouldering in the tool and the cam angle.

If the heights h_1 and h_2 (see figure below) in the tool are reduced, the forces of the shouldering cannot be fully born.

For exact details, please refer to the catalogue information for your cam on the internet at www.strack.de

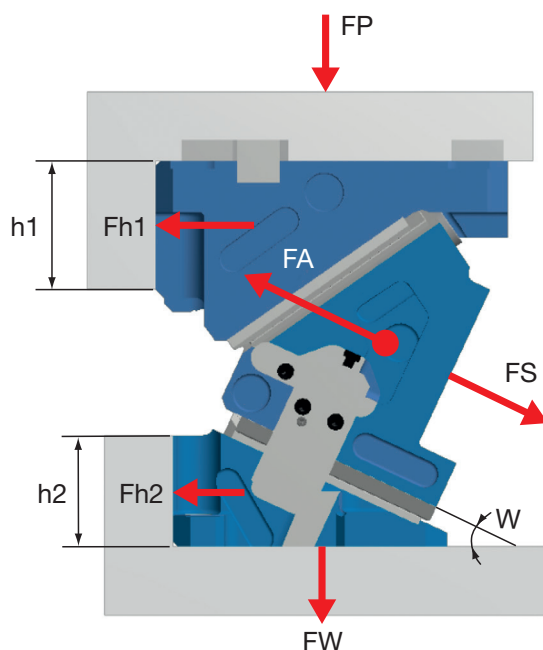

PowerMax cam unit SN5650-PMO-0330 — SN5650-PMO-1200

7.1. Centring in the tool by means of dowel pin and/or slot nuts

In version V04 STRACK Norma has combined the „Z“ dowel pin and „N“ slot nut from the familiar centring in a new version. This offers the user new flexible possibilities as described under 7.1.1 up to 7.1.4.

COMBINATIONS ARE FREELY SELECTABLE BY THE CUSTOMER:

- 7.1.1 Dowel pin (old „Z“)
- 7.1.2 Slot nuts LONG + CROSS (old „N“)
- 7.1.3 Slot nut CROSS + dowel pin
- 7.1.4 Slot nut LONG + dowel pin

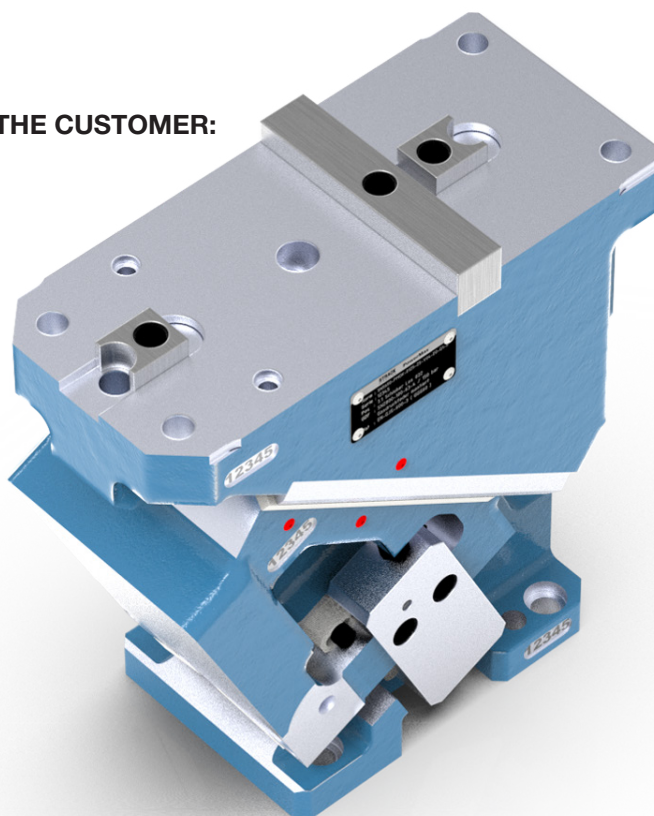

7.1.1 Dowel pin (old „Z“)

- Position cam retainer in the tool
- Set dowel pin



Direction of fine adjustment possible before pinning in both positions



End position fixed by dowel pin

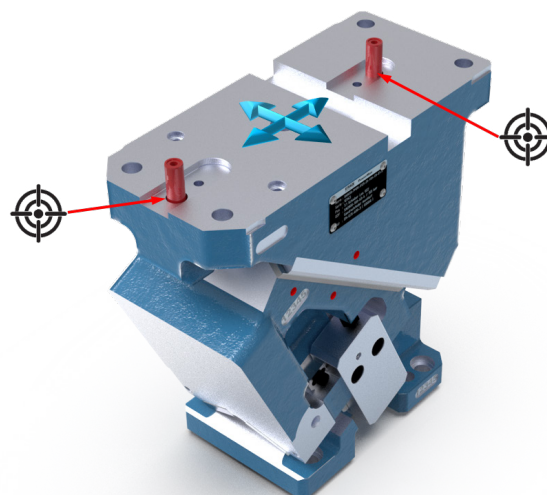

PowerMax cam unit SN5650-PMO-0330 — SN5650-PMO-1200

7.1.2 SLOT NUTS LONG + CROSS (OLD "N")

- Slot nuts in longitudinal- and transverse direction determine position



Fine adjustment not possible



End position determined by slot nuts

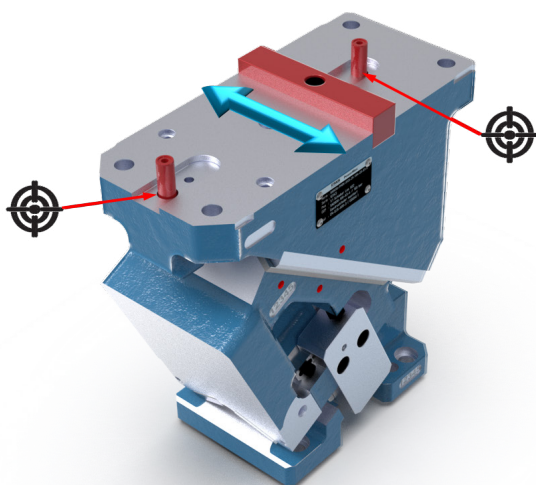
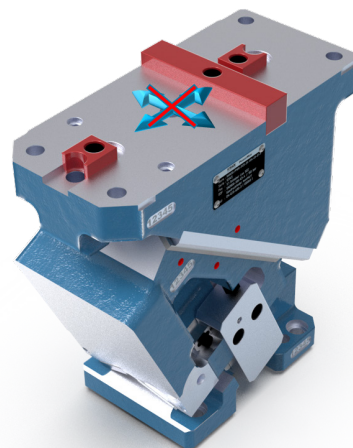

7.1.3 Slot nut CROSS + dowel pin

- Slide retainer fixed in the upper part of the tool in longitudinal axis by feather key.
- Can be moved transversely for fine positioning
- Dowel pin sets final position



Direction of fine adjustment



End position is determined by dowel pin

7.1.4 Slot nut LONG + dowel pin

- Cam retainer is fixed in the upper part of the tool in transverse axis by feather key.
- Can be moved longitudinally for fine positioning
- Dowel pin sets final position

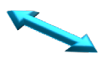

Direction of fine adjustment



End position is determined by dowel pin

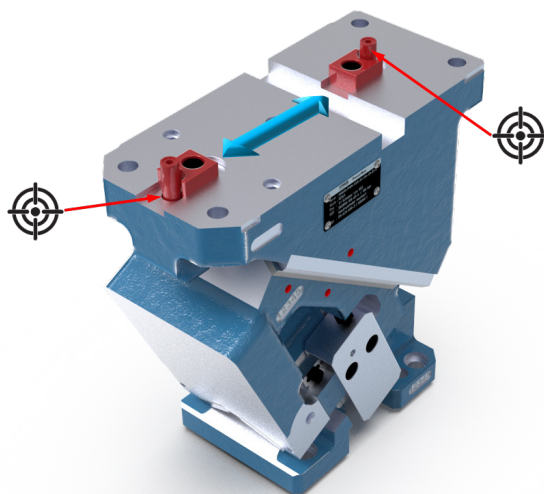

PowerMax cam unit SN5650-PMO-0065 — SN5650-PMO-0260

8. Production

During production no special precautions have to be taken that go beyond the valid Industrial Safe Ordinance paragraph 3.



All information without warranty

Attention:

If attachments are dismantled in the assembly process, these must be then secured again with Loctite 242.

Notes on tightening torques:

Screws DIN EN ISO 4762-10.9	M6	M8	M10	M12	M16	M20
Tightening torque [Nm]	14	33	65	121	302	590



Note:

Make sure that the STRACK PowerMax cams, especially the gas springs are not immersed in liquid.

If, for example, aggressive drawing oils are used during the production, create a controlled drain (drainage holes, cut-outs etc.) for this so that the liquids are led away from the gas springs.

This prevents damage to the seals.



Tip:

Check the nitrogen pressure of the gas springs at regular intervals to detect changes in the pressure level in time. When carrying out maintenance work make sure that the cam slide is properly returned.



Note:

The PowerMax cam units are equipped with low-maintenance slide elements out of SNS-sintered metal. Normally a lubrication is not necessary.

If necessary, a lubrication can only be carried out according to chapter 14 Maintenance.

PowerMax cam unit SN5650-PMO-0330 — SN5650-PMO-1200

8.1 Handling with safety ring bolt (SN1594)

8.1.1 Mounting of the cam slide in the cam retainer

From cam widths 330 onwards, the cam retainer and slide can be mounted together in a simplified manner by means of the safety ring bolt SN1594 as the different positions of the threads of the supporting screws facilitate the threading of the cam slide in the cam retainer.

8.1.2 8.1.2 Mounting of the cam slide with cam retainer in the upper part of the tool with central transport thread

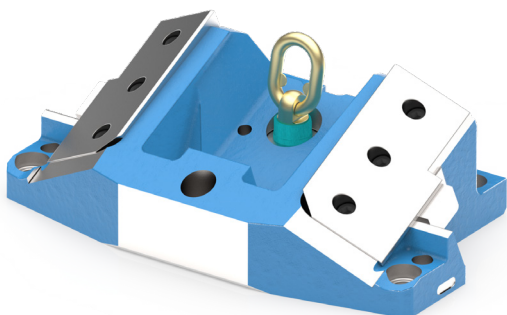

By changing of the position of the safety ring bolt, the cam retainer and cam slide can be mounted more easily together in the tool.

8.1.3 Mounting of the cam slide with cam retainer in the upper part of the tool with lateral transport thread

Installation of cam retainer with cam slide in the tool with lateral thread for flexible installation and turning of the cam.

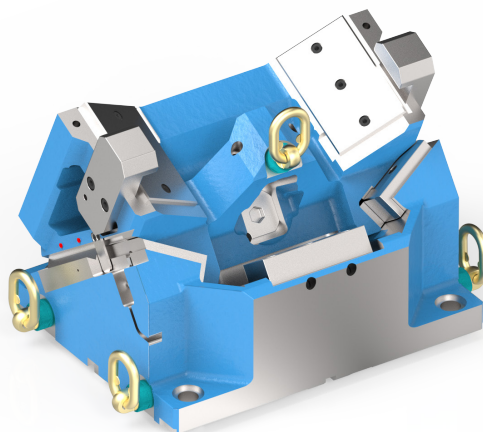

PowerMax cam unit SN5650-PMO-0330 — SN5650-PMO-1200

8.2 Marking of the cams

All PowerMax cams are equipped with a type plate.

The name and the serial number are lasered onto this type plate.

Cam designation →
6-digit serial number for →
additional information of →
the customer

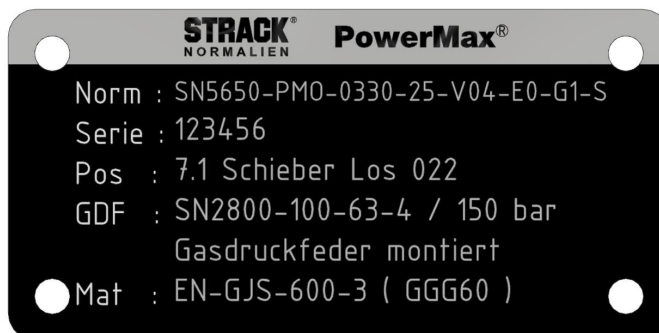

The serial number refers to all cams of an order and is different from order to order. The PowerMax-cams were adjusted at STRACK. For this purpose, the hardened steel slide bars were ground to the appropriate size. The corresponding screws were additionally secured with Z9093 screw locking adhesive.

To avoid confusion within a series, the assemblies of the individual sliders within a series are marked with serial numbers (see picture below). During the mounting make absolutely sure that the components are correctly assigned in order to avoid problems.

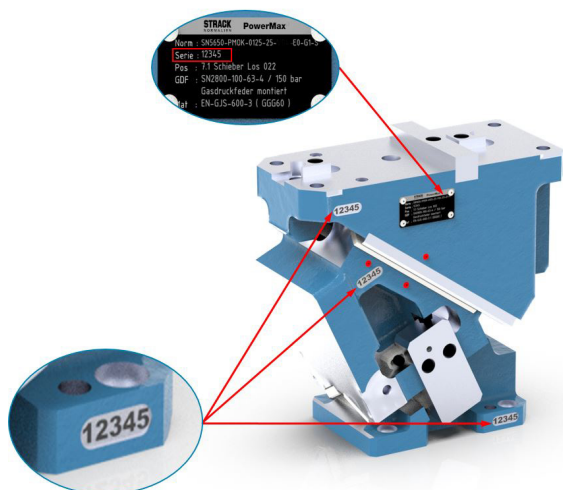

Additional markings on the cam retainer and cam body make it possible to control the position of the cam in the tool.

When the cam is retracted the upper markings are standing together, at extended cams the lower markings are standing together.

If the marking on the cam body is between those of the retainer, the whole cam is not returned to the correct starting position.

PowerMax cam unit SN5650-PMO-0330 — SN5650-PMO-1200

8.3 Optional sensor for position monitoring

Optionally the PowerMax cams can be ordered with a sensor for position monitoring. The sensor plate contacts the inductive limit switch Z7685 during the upward movement and signals to the machine that the cam slide is in the rearmost position.

For more information on the Z7685 limit switch see the appendix.

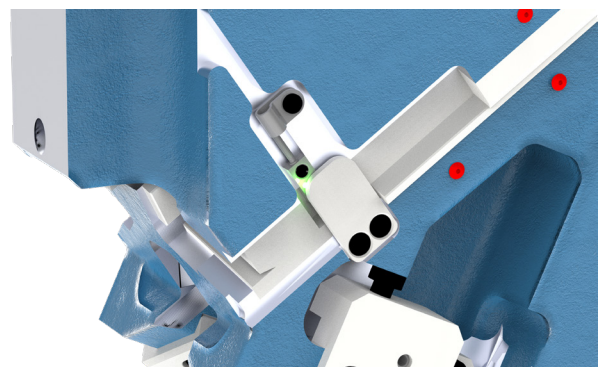
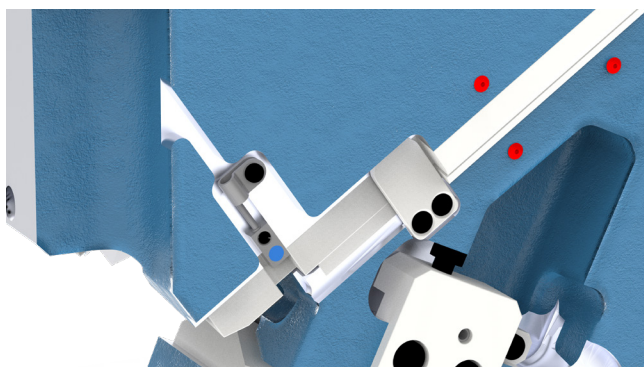
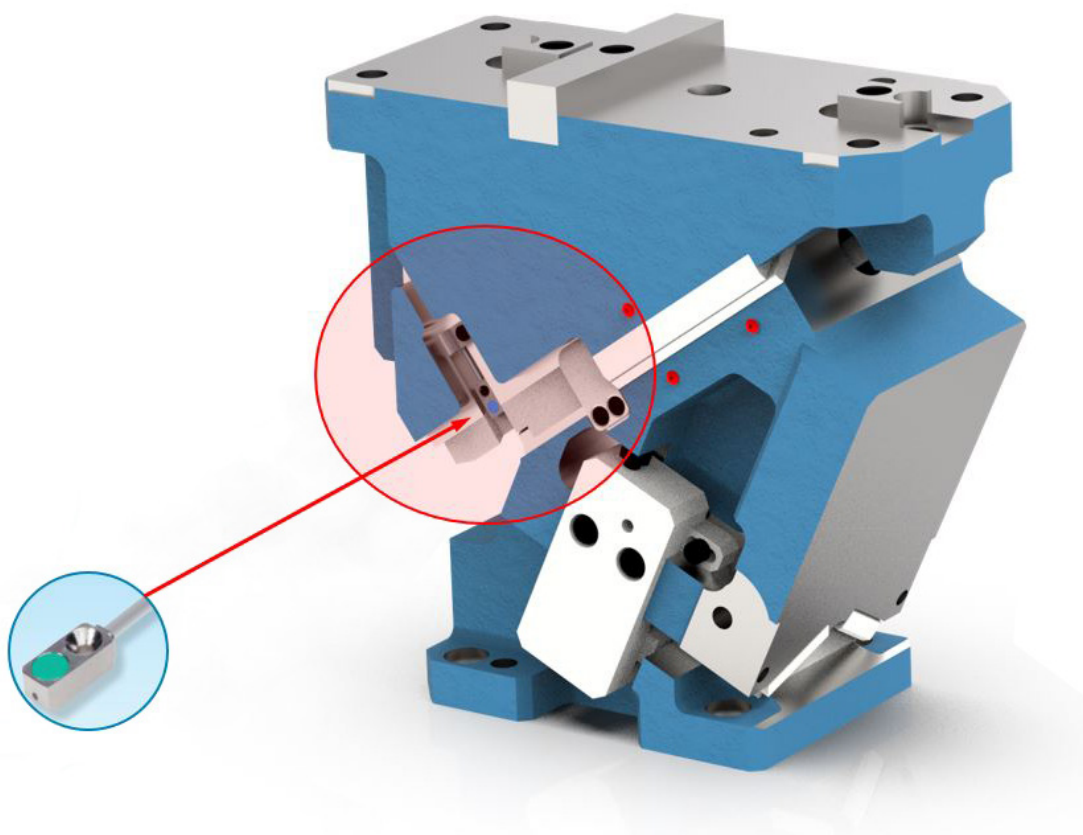

PowerMax cam unit SN5650-PMO-0065 — SN5650-PMO-0260

9. Lock-Out-System SN5654-LOS

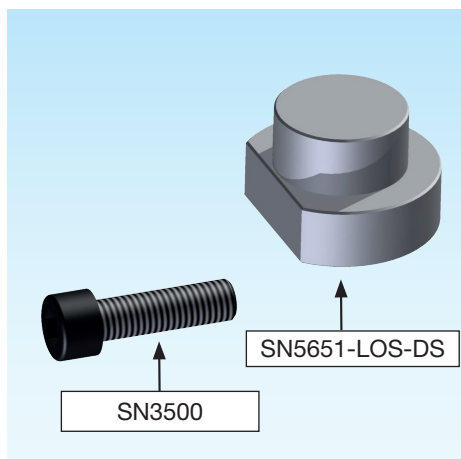

SN5654-LOS



SN5654-LOS-Type



Mat.: ST

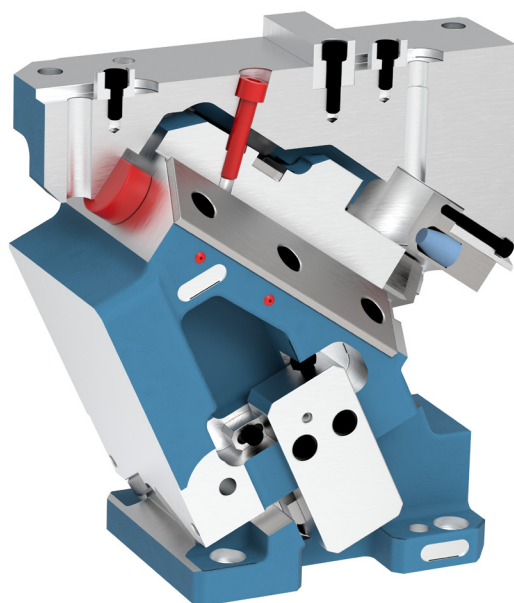

weitere Angaben unter: www.strack.de

Type		Screw	Piece	Screw	Piece	Pressure piece	Piece
PMO 0065							
SN5654-PMO-LOS-0065-00	00°	SN3500-M8-60	1	-	-	SN5651-LOS-DS-19x15	1
SN5654-PMO-LOS-0065-05	05°	SN3500-M8-50	1	-	-	SN5651-LOS-DS-19x15	1
SN5654-PMO-LOS-0065-10	10°	SN3500-M8-45	1	-	-	SN5651-LOS-DS-19x15	1
SN5654-PMO-LOS-0065-15	15°	SN3500-M8-45	1	-	-	SN5651-LOS-DS-19x15	1
SN5654-PMO-LOS-0065-20	20°	SN3500-M8-55	1	-	-	SN5651-LOS-DS-19x15	1
SN5654-PMO-LOS-0065-25	25°	SN3500-M8-50	1	-	-	SN5651-LOS-DS-19x15	1
SN5654-PMO-LOS-0065-30	30°	SN3500-M8-50	1	-	-	SN5651-LOS-DS-19x15	1
SN5654-PMO-LOS-0065-35	35°	SN3500-M8-45	1	-	-	SN5651-LOS-DS-19x15	1
SN5654-PMO-LOS-0065-40	40°	SN3500-M8-45	1	-	-	SN5651-LOS-DS-19x15	1
SN5654-PMO-LOS-0065-45	45°	SN3500-M8-45	1	-	-	SN5651-LOS-DS-19x15	1
SN5654-PMO-LOS-0065-50	50°	SN3500-M8-40	1	-	-	SN5651-LOS-DS-19x15	1
SN5654-PMO-LOS-0065-55	55°	SN3500-M8-40	1	-	-	SN5651-LOS-DS-19x15	1
SN5654-PMO-LOS-0065-60	60°	SN3500-M8-40	1	-	-	SN5651-LOS-DS-19x15	1
SN5654-PMO-LOS-0065-65	65°	SN3500-M8-40	1	-	-	SN5651-LOS-DS-19x15	1
SN5654-PMO-LOS-0065-70	70°	SN3500-M8-40	1	-	-	SN5651-LOS-DS-19x15	1
SN5654-PMO-LOS-0065-75	75°	SN3500-M8-40	1	-	-	SN5651-LOS-DS-19x15	1

PowerMax cam unit SN5650-PMO-0330 — SN5650-PMO-1200

Type		Schraube	Stk	Schraube	Stk	Druckstück	Stk
------	--	----------	-----	----------	-----	------------	-----

PMO 0400

SN5654-PMO-LOS-0400-00	00°	SN3500-M12-110	1	SN3500-M12-50	1	SN5651-LOS-DS-50x20	1
SN5654-PMO-LOS-0400-05	05°	SN3500-M12-110	1	SN3500-M12-50	1	SN5651-LOS-DS-50x20	1
SN5654-PMO-LOS-0400-10	10°	SN3500-M12-100	1	SN3500-M12-45	1	SN5651-LOS-DS-50x20	1
SN5654-PMO-LOS-0400-15	15°	SN3500-M12-80	1	SN3500-M12-45	1	SN5651-LOS-DS-50x20	1
SN5654-PMO-LOS-0400-20	20°	SN3500-M12-80	1	SN3500-M12-45	1	SN5651-LOS-DS-50x20	1
SN5654-PMO-LOS-0400-25	25°	SN3500-M12-70	1	SN3500-M12-45	1	SN5651-LOS-DS-50x20	1
SN5654-PMO-LOS-0400-30	30°	SN3500-M12-70	1	SN3500-M12-45	1	SN5651-LOS-DS-50x20	1
SN5654-PMO-LOS-0400-35	35°	SN3500-M12-60	1	SN3500-M12-45	1	SN5651-LOS-DS-50x20	1
SN5654-PMO-LOS-0400-40	40°	SN3500-M12-65	1	SN3500-M12-45	1	SN5651-LOS-DS-50x20	1
SN5654-PMO-LOS-0400-45	45°	SN3500-M12-60	1	SN3500-M12-45	1	SN5651-LOS-DS-50x20	1
SN5654-PMO-LOS-0400-50	50°	SN3500-M12-60	1	SN3500-M12-50	1	SN5651-LOS-DS-50x20	1
SN5654-PMO-LOS-0400-55	55°	SN3500-M12-60	1	SN3500-M12-50	1	SN5651-LOS-DS-50x20	1
SN5654-PMO-LOS-0400-60	60°	SN3500-M12-65	1	SN3500-M12-50	1	SN5651-LOS-DS-50x20	1
SN5654-PMO-LOS-0400-65	65°	SN3500-M12-65	1	SN3500-M12-50	1	SN5651-LOS-DS-50x20	1

PMO 0460

SN5654-PMO-LOS-0460-00	00°	SN3500-M12-110	3	SN3500-M12-110	-	SN5651-LOS-DS-50x20	1
SN5654-PMO-LOS-0460-05	05°	SN3500-M12-110	3	SN3500-M12-110	-	SN5651-LOS-DS-50x20	1
SN5654-PMO-LOS-0460-10	10°	SN3500-M12-90	3	SN3500-M12-90	-	SN5651-LOS-DS-50x20	1
SN5654-PMO-LOS-0460-15	15°	SN3500-M12-90	3	SN3500-M12-90	-	SN5651-LOS-DS-50x20	1
SN5654-PMO-LOS-0460-20	20°	SN3500-M12-90	3	SN3500-M12-90	-	SN5651-LOS-DS-50x20	1
SN5654-PMO-LOS-0460-25	25°	SN3500-M12-70	3	SN3500-M12-80	2	SN5651-LOS-DS-50x20	1
SN5654-PMO-LOS-0460-30	30°	SN3500-M12-80	3	SN3500-M12-80	-	SN5651-LOS-DS-50x20	1
SN5654-PMO-LOS-0460-35	35°	SN3500-M12-70	3	SN3500-M12-70	-	SN5651-LOS-DS-50x20	1
SN5654-PMO-LOS-0460-40	40°	SN3500-M12-80	3	SN3500-M12-80	-	SN5651-LOS-DS-50x20	1
SN5654-PMO-LOS-0460-45	45°	SN3500-M12-70	3	SN3500-M12-70	-	SN5651-LOS-DS-50x20	1
SN5654-PMO-LOS-0460-50	50°	SN3500-M12-70	3	SN3500-M12-70	-	SN5651-LOS-DS-50x20	1
SN5654-PMO-LOS-0460-55	55°	SN3500-M12-60	3	SN3500-M12-60	-	SN5651-LOS-DS-50x20	1
SN5654-PMO-LOS-0460-60	60°	SN3500-M12-60	3	SN3500-M12-70	2	SN5651-LOS-DS-50x20	1
SN5654-PMO-LOS-0460-65	65°	SN3500-M12-50	3	SN3500-M12-65	2	SN5651-LOS-DS-50x20	1

PMO 0580

SN5654-PMO-LOS-0580-00	00°	SN3500-M12-170	1	SN3500-M12-100	2	SN5651-LOS-DS-50x20	2
SN5654-PMO-LOS-0580-05	05°	SN3500-M12-150	1	SN3500-M12-100	2	SN5651-LOS-DS-50x20	2
SN5654-PMO-LOS-0580-10	10°	SN3500-M12-150	1	SN3500-M12-90	2	SN5651-LOS-DS-50x20	2
SN5654-PMO-LOS-0580-15	15°	SN3500-M12-150	1	SN3500-M12-80	2	SN5651-LOS-DS-50x20	2
SN5654-PMO-LOS-0580-20	20°	SN3500-M12-140	1	SN3500-M12-90	2	SN5651-LOS-DS-50x20	2
SN5654-PMO-LOS-0580-25	25°	SN3500-M12-140	1	SN3500-M12-80	2	SN5651-LOS-DS-50x20	2
SN5654-PMO-LOS-0580-30	30°	SN3500-M12-140	1	SN3500-M12-80	2	SN5651-LOS-DS-50x20	2
SN5654-PMO-LOS-0580-35	35°	SN3500-M12-140	1	SN3500-M12-70	2	SN5651-LOS-DS-50x20	2

PowerMax cam unit SN5650-PMO-0330 — SN5650-PMO-1200

Type		Schraube	Stk	Schraube	Stk	Druckstück	Stk
------	--	----------	-----	----------	-----	------------	-----

PMO 0580

SN5654-PMO-LOS-0580-40	40°	SN3500-M12-140	1	SN3500-M12-80	2	SN5651-LOS-DS-50x20	2
SN5654-PMO-LOS-0580-45	45°	SN3500-M12-140	1	SN3500-M12-70	2	SN5651-LOS-DS-50x20	2
SN5654-PMO-LOS-0580-50	50°	SN3500-M12-140	1	SN3500-M12-70	2	SN5651-LOS-DS-50x20	2
SN5654-PMO-LOS-0580-55	55°	SN3500-M12-130	1	SN3500-M12-60	2	SN5651-LOS-DS-50x20	2
SN5654-PMO-LOS-0580-60	60°	SN3500-M12-120	1	SN3500-M12-70	2	SN5651-LOS-DS-50x20	2
SN5654-PMO-LOS-0580-65	65°	SN3500-M12-120	1	SN3500-M12-70	2	SN5651-LOS-DS-50x20	2

PMO 0700

SN5654-PMO-LOS-0700-00	00°	SN3500-M12-170	1	SN3500-M12-100	2	SN5651-LOS-DS-50x20	2
SN5654-PMO-LOS-0700-05	05°	SN3500-M12-150	1	SN3500-M12-100	2	SN5651-LOS-DS-50x20	2
SN5654-PMO-LOS-0700-10	10°	SN3500-M12-140	1	SN3500-M12-90	2	SN5651-LOS-DS-50x20	2
SN5654-PMO-LOS-0700-15	15°	SN3500-M12-150	1	SN3500-M12-90	2	SN5651-LOS-DS-50x20	2
SN5654-PMO-LOS-0700-20	20°	SN3500-M12-150	1	SN3500-M12-90	2	SN5651-LOS-DS-50x20	2
SN5654-PMO-LOS-0700-25	25°	SN3500-M12-140	1	SN3500-M12-80	2	SN5651-LOS-DS-50x20	2
SN5654-PMO-LOS-0700-30	30°	SN3500-M12-140	1	SN3500-M12-80	2	SN5651-LOS-DS-50x20	2
SN5654-PMO-LOS-0700-35	35°	SN3500-M12-140	1	SN3500-M12-80	2	SN5651-LOS-DS-50x20	2
SN5654-PMO-LOS-0700-40	40°	SN3500-M12-140	1	SN3500-M12-80	2	SN5651-LOS-DS-50x20	2
SN5654-PMO-LOS-0700-45	45°	SN3500-M12-140	1	SN3500-M12-70	2	SN5651-LOS-DS-50x20	2
SN5654-PMO-LOS-0700-50	50°	SN3500-M12-140	1	SN3500-M12-70	2	SN5651-LOS-DS-50x20	2
SN5654-PMO-LOS-0700-55	55°	SN3500-M12-130	1	SN3500-M12-65	2	SN5651-LOS-DS-50x20	2
SN5654-PMO-LOS-0700-60	60°	SN3500-M12-120	1	SN3500-M12-70	2	SN5651-LOS-DS-50x20	2
SN5654-PMO-LOS-0700-65	65°	SN3500-M12-120	1	SN3500-M12-70	2	SN5651-LOS-DS-50x20	2

PMO 0850

SN5654-PMO-LOS-0850-00	00°	SN3500-M16-130	1	SN3500-M16-100	2	SN5651-LOS-DS-50x20	2
SN5654-PMO-LOS-0850-05	05°	SN3500-M16-120	1	SN3500-M16-100	2	SN5651-LOS-DS-50x20	2
SN5654-PMO-LOS-0850-10	10°	SN3500-M16-120	1	SN3500-M16-90	2	SN5651-LOS-DS-50x20	2
SN5654-PMO-LOS-0850-15	15°	SN3500-M16-120	1	SN3500-M16-90	2	SN5651-LOS-DS-50x20	2
SN5654-PMO-LOS-0850-20	20°	SN3500-M16-130	1	SN3500-M16-90	2	SN5651-LOS-DS-50x20	2
SN5654-PMO-LOS-0850-25	25°	SN3500-M16-110	1	SN3500-M16-90	2	SN5651-LOS-DS-50x20	2
SN5654-PMO-LOS-0850-30	30°	SN3500-M16-110	1	SN3500-M16-80	2	SN5651-LOS-DS-50x20	2
SN5654-PMO-LOS-0850-35	35°	SN3500-M16-110	1	SN3500-M16-80	2	SN5651-LOS-DS-50x20	2
SN5654-PMO-LOS-0850-40	40°	SN3500-M16-110	1	SN3500-M16-80	2	SN5651-LOS-DS-50x20	2
SN5654-PMO-LOS-0850-45	45°	SN3500-M16-110	1	SN3500-M16-80	2	SN5651-LOS-DS-50x20	2
SN5654-PMO-LOS-0850-50	50°	SN3500-M16-110	1	SN3500-M16-80	2	SN5651-LOS-DS-50x20	2
SN5654-PMO-LOS-0850-55	55°	SN3500-M16-110	1	SN3500-M16-70	2	SN5651-LOS-DS-50x20	2
SN5654-PMO-LOS-0850-60	60°	SN3500-M16-110	1	SN3500-M16-70	2	SN5651-LOS-DS-50x20	2
SN5654-PMO-LOS-0850-65	65°	SN3500-M16-100	1	SN3500-M16-70	2	SN5651-LOS-DS-50x20	2

PowerMax cam unit SN5650-PMO-0330 — SN5650-PMO-1200

Type		Schraube	Stk	Schraube	Stk	Druckstück	Stk
------	--	----------	-----	----------	-----	------------	-----

PMO 1000

SN5654-PMO-LOS-1000-00	00°	SN3500-M16-130	1	SN3500-M16-100	2	SN5651-LOS-DS-50x20	2
SN5654-PMO-LOS-1000-05	05°	SN3500-M16-120	1	SN3500-M16-100	2	SN5651-LOS-DS-50x20	2
SN5654-PMO-LOS-1000-10	10°	SN3500-M16-120	1	SN3500-M16-90	2	SN5651-LOS-DS-50x20	2
SN5654-PMO-LOS-1000-15	15°	SN3500-M16-120	1	SN3500-M16-90	2	SN5651-LOS-DS-50x20	2
SN5654-PMO-LOS-1000-20	20°	SN3500-M16-130	1	SN3500-M16-90	2	SN5651-LOS-DS-50x20	2
SN5654-PMO-LOS-1000-25	25°	SN3500-M16-110	1	SN3500-M16-90	2	SN5651-LOS-DS-50x20	2
SN5654-PMO-LOS-1000-30	30°	SN3500-M16-110	1	SN3500-M16-80	2	SN5651-LOS-DS-50x20	2
SN5654-PMO-LOS-1000-35	35°	SN3500-M16-110	1	SN3500-M16-80	2	SN5651-LOS-DS-50x20	2
SN5654-PMO-LOS-1000-40	40°	SN3500-M16-110	1	SN3500-M16-80	2	SN5651-LOS-DS-50x20	2
SN5654-PMO-LOS-1000-45	45°	SN3500-M16-110	1	SN3500-M16-80	2	SN5651-LOS-DS-50x20	2
SN5654-PMO-LOS-1000-50	50°	SN3500-M16-110	1	SN3500-M16-80	2	SN5651-LOS-DS-50x20	2
SN5654-PMO-LOS-1000-55	55°	SN3500-M16-110	1	SN3500-M16-70	2	SN5651-LOS-DS-50x20	2
SN5654-PMO-LOS-1000-60	60°	SN3500-M16-110	1	SN3500-M16-70	2	SN5651-LOS-DS-50x20	2
SN5654-PMO-LOS-1000-65	65°	SN3500-M16-100	1	SN3500-M16-70	2	SN5651-LOS-DS-50x20	2

PMO 1200

SN5654-PMO-LOS-1000-00	00°	SN3500-M16-130	1	SN3500-M16-100	2	SN5651-LOS-DS-50x20	2
SN5654-PMO-LOS-1000-05	05°	SN3500-M16-120	1	SN3500-M16-100	2	SN5651-LOS-DS-50x20	2
SN5654-PMO-LOS-1000-10	10°	SN3500-M16-120	1	SN3500-M16-90	2	SN5651-LOS-DS-50x20	2
SN5654-PMO-LOS-1000-15	15°	SN3500-M16-120	1	SN3500-M16-90	2	SN5651-LOS-DS-50x20	2
SN5654-PMO-LOS-1000-20	20°	SN3500-M16-130	1	SN3500-M16-90	2	SN5651-LOS-DS-50x20	2
SN5654-PMO-LOS-1000-25	25°	SN3500-M16-110	1	SN3500-M16-90	2	SN5651-LOS-DS-50x20	2
SN5654-PMO-LOS-1000-30	30°	SN3500-M16-110	1	SN3500-M16-80	2	SN5651-LOS-DS-50x20	2
SN5654-PMO-LOS-1000-35	35°	SN3500-M16-110	1	SN3500-M16-80	2	SN5651-LOS-DS-50x20	2
SN5654-PMO-LOS-1000-40	40°	SN3500-M16-110	1	SN3500-M16-80	2	SN5651-LOS-DS-50x20	2
SN5654-PMO-LOS-1000-45	45°	SN3500-M16-110	1	SN3500-M16-80	2	SN5651-LOS-DS-50x20	2
SN5654-PMO-LOS-1000-50	50°	SN3500-M16-110	1	SN3500-M16-80	2	SN5651-LOS-DS-50x20	2
SN5654-PMO-LOS-1000-55	55°	SN3500-M16-110	1	SN3500-M16-70	2	SN5651-LOS-DS-50x20	2
SN5654-PMO-LOS-1000-60	60°	SN3500-M16-110	1	SN3500-M16-70	2	SN5651-LOS-DS-50x20	2
SN5654-PMO-LOS-1000-65	65°	SN3500-M16-100	1	SN3500-M16-70	2	SN5651-LOS-DS-50x20	2

PowerMax cam unit SN5650-PMO-0330 — SN5650-PMO-1200

9.1 Information concerning Lock-Out-System SN5654-LOS

Force distribution:

With the newly developed Lock-Out-System it is possible to fix the corresponding cam without play in its front-end position.

For this purpose, the cam body is screwed with the cam retainer. The special feature of this system is, that the clamping screws act at an angle to the corresponding bearing surface.

That means that the cam body is pulled by the divided (resulting) forces once against the prismatically arranged sliding strips and simultaneously at the pressure piece. Now, the cam body is exactly positioned without play in its front-end position and is now prepared for additional machining.

Please consider that the Lock-Out-System can only be used with dismantled cams.

With most of the PowerMax-cams, the fixing holes are partially covered if the cam body is in the front-end position.

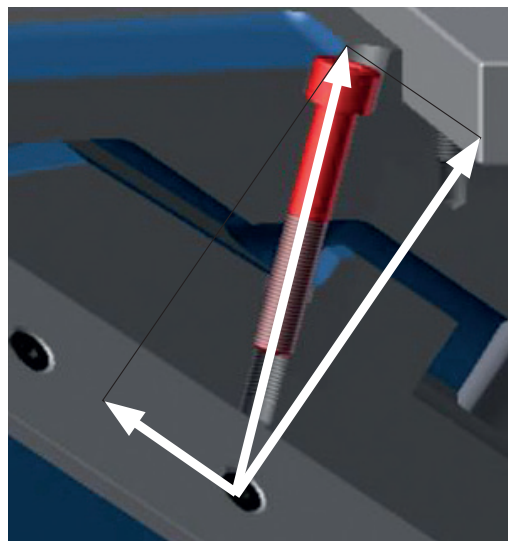
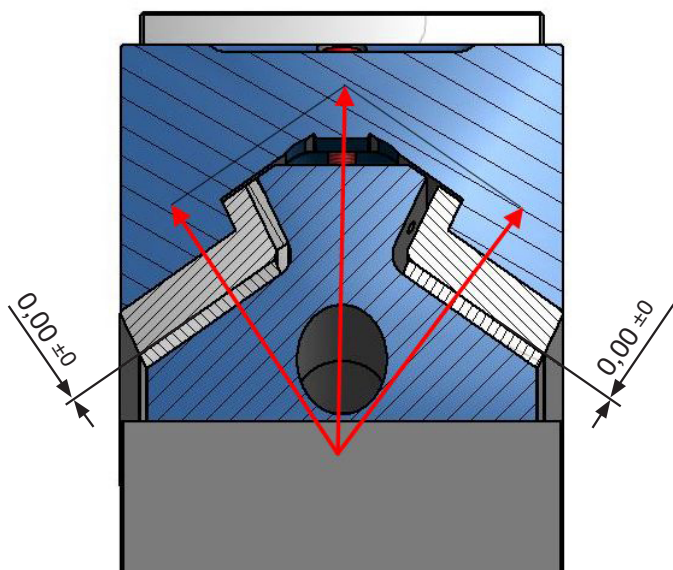
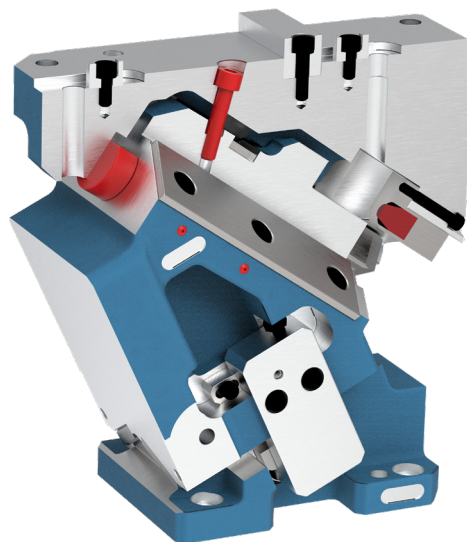

PowerMax cam unit SN5650-PMO-0330 — SN5650-PMO-1200

10. Disassembly/ Assembly of the gas springs

To remove the gas spring from the cam, at first the locking screw and the bayonet lock have to be de-mounted.



ATTENTION: after the bayonet lock has been removed the cam slide falls in its lower end position. From a cam width of 230 the cam slide must be secured in the rear position by an additional screw (4) in the cam stop (5). The installation is done in reverse order. To do this, the cam slide must be pulled back so that the bayonet lock (2) can be turned. The bayonet lock (2) must then be secured with the locking screw (1).



ACHTUNG: Hinweise Optik wie bei Punkt 8!

1. Demontage der Gasdruckfedern



Bild 1



Bild 2

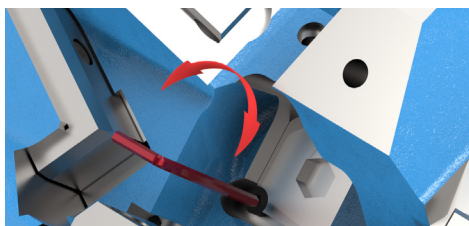

Bild 3

Sicherungs-
schraube für
Schieberschlitten

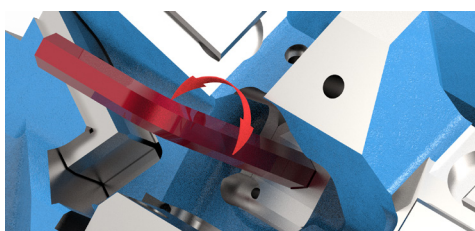
Verletzungs-
gefahr

2. Montage der Gasdruckfedern

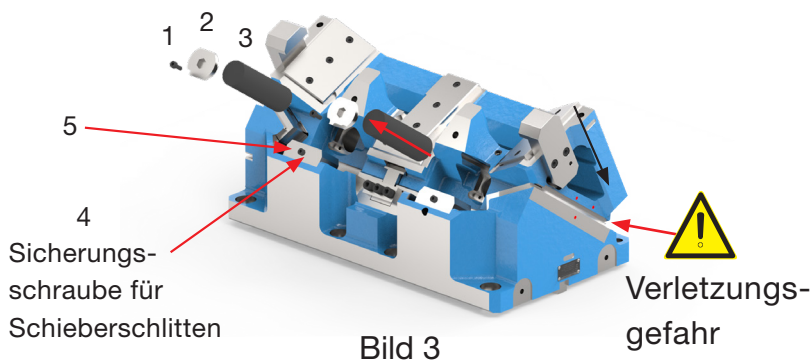
Führen Sie die Gasdruckfeder (3) in die dafür vorgesehene Bohrung (Bild 4). Stecken Sie den Bajonetverschluss (2) in die vorgesehene Öffnung und verdrehen ihn um 90°.

Anschließend schrauben Sie die Sicherungsschraube (1) ein und ziehen sie mit 33 Nm an.

ACHTUNG!

Verwenden Sie zur Schraubensicherung Loctite 243 mittelfest.



Bild 4

PowerMax cam unit SN5650-PMO-0330 — SN5650-PMO-1200

11. Modification of the system pressure of the gas springs

11.1 Releasing of the pressure of a gas spring

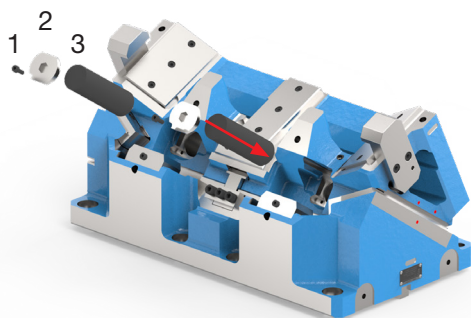
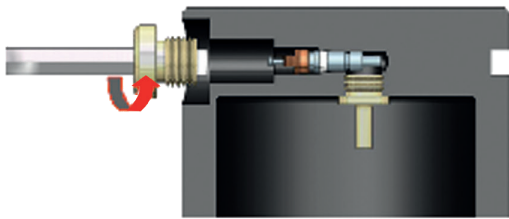

1. If necessary, remove the closing plug.

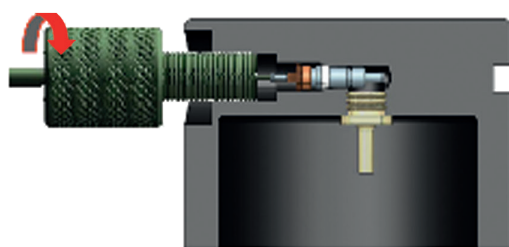

2. to allow the gas to escape, turn the discharge nozzle SN2955 into the G1/8" thread until the gas escapes.
the gas escapes.

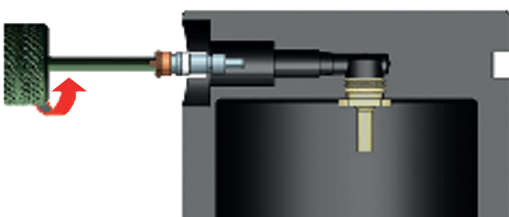

3. to remove the filling valve turn the discharge nozzle around and turn the filling valve to the to the left until it is released.

PowerMax cam unit SN5650-PMO-0330 — SN5650-PMO-1200

11.2 Increasing of the pressure / filling of a gas spring

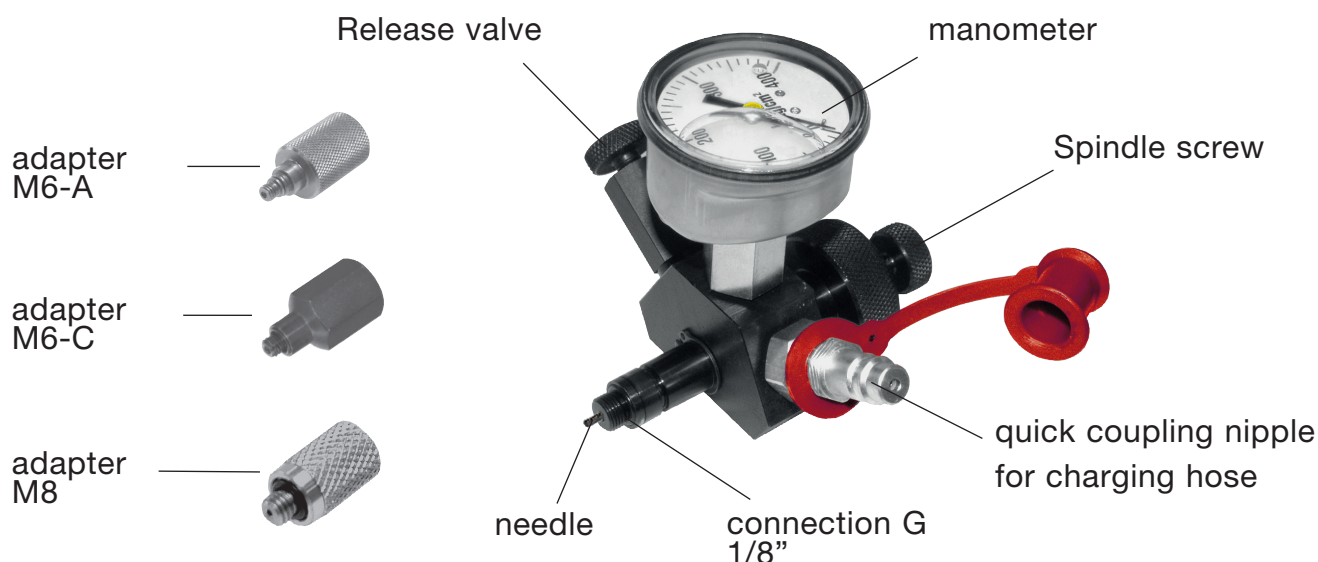

Attention!

Please consider!

Minimum pressure 25 bar

Minimum pressure 175 bar

Filling of gas springs

For gas springs with G1/8' connection thread:

1. Turn back the spindle screw until the needle is flush in the middle of the G1/8" connection.
2. Turn the loading equipment with the connection G1/8" in the gas spring. Continue with step 3.
3. Put the coupling of the charging hose onto the quick-coupling nipple.
4. Open slowly the valve on the charging hose until the desired pressure is indicated on the manometer (close the valve).

For gas springs with connection thread M6-A/M8:

- 2a Turn the M6-A/M8 adapter on the connection thread G1/8".
- 2b Turn the loading equipment with the connection M6 into the gas spring. Continue with step 3.

5. The valve in the gas spring closes automatically. To release the pressure which still is in the charging equipment slowly turn in the screw of the release valve until the residual pressure is released. Then immediately turn back the adjusting screw of the release valve back to its initial position.

6. Turn the loading equipment out of the gas spring.

PowerMax cam unit SN5650-PMO-0065 — SN5650-PMO-0260

Pressure monitoring of gas springs with connection thread G1/8"

1. Turn back the spindle screw until the needle is flush in the middle of the G1/8" connection (fig.1).
2. Turn the loading equipment with the connection G1/8" into the gas spring.
3. By turning the spindle screw the needle opens the valve in the gas spring and the pressure is displayed on the manometer.

Pressure monitoring of gas springs with connection thread M6: is not possible!

Releasing or reducing of pressure at gas springs with connection thread G1/8"

1. Proceed as in steps 1–3 at pressure monitoring of gas springs with connection thread G1/8".
2. To release the pressure in the gas spring, slowly turn in the screw of the release valve until the pressure escapes or until the desired pressure is displayed on the manometer. Then immediately turn the adjusting screw back to its initial position.

To ensure that the gas spring is depressurized, the piston rod must be able to be pressed down by hand!

The gas spring may only be dismantled in depressurized condition!



Fig. 1

Release pressure at gas springs connection thread M6

1. Gas springs with connection thread M6 cannot be released with the charging equipment SN2967! The needle of the charging equipment cannot be turned through the screwed-on M6-A adapter.
2. Gas springs of the series SN2900 and SN2910-M16 and SN2910-M24 have a poppet valve SN2992. Continue with step 5.
3. To release the pressure of a gas spring with thread M6 use the discharging nozzle SN2955-M6 (fig.2).
4. Use side B to screw the valve out of the gas spring.
5. Proceed as described in fig. 3. To release pressure, turn the poppet valve SN2992 clockwise, one or two turns, until the gas starts to escape. Stop and wait until the gas has escaped. Then turn the poppet valve anticlockwise to close it again (fig. 4).

fig.1

SN2955-M6 Discharging nozzle

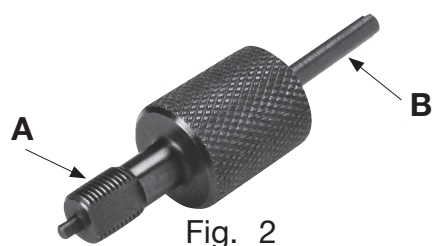

Fig. 2

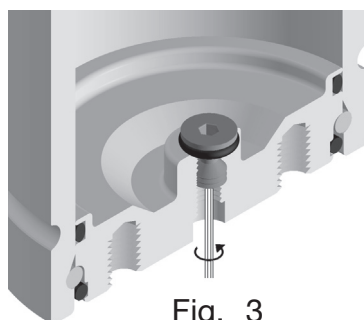

Fig. 3

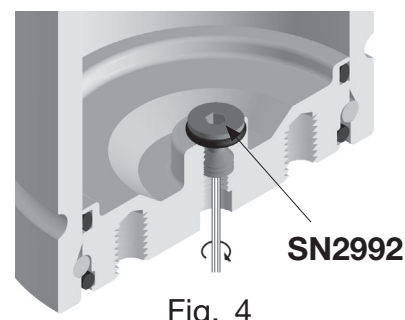

Fig. 4

PowerMax cam unit SN5650-PMO-0330 — SN5650-PMO-1200

12. Stillstand and storage

Stillstand

During the standstill of the press no special precautions have to be taken that go beyond the usual applicable regulations for pressurised gas-controlled applications.

Storage

For transport or storage of the tool with installed STRACK nitrogen spring system it is advisable to release the system pressure.



Please consider that due to the design, components of the tool may move together in an uncontrolled manner due to the lowering of the system pressure in the gas springs of the cam units (UVV).

Before putting the tool back into operation, check the system pressure of the gas springs. If you have to increase the system pressure again, proceed as described in chapter 11.2.

13. Maintenance

Sliding strips out of steel are hardened and are normally not subject to wear.

If necessary, these strips are adjusted at STRACK during the assembly to guarantee a low guide play.

The fixing screws of these strips are secured with the screw lock Z9093.

The sliding strips out of SNS sintered are subject to higher wear than the steel strips. The strips are manufactured in a narrow tolerance range. This means that these elements can be exchanged without having to be readjusted. If both slide partners are replaced, the guide play must be controlled and be readjusted, if necessary.

PowerMax cam unit SN5650-PMO-0330 — SN5650-PMO-1200

13.1 Voreinstellung des Aktivrückzuges

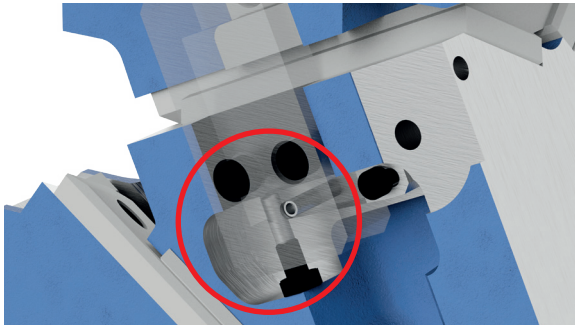

The active retractors are adjusted and pinned at the factory. Check the play between the insert and the active retractor regularly. In case of increased play due to wear, this can be readjusted. To do this, remove the cylindrical pin, which can then no longer be used. Continue as described.

The preset active retraction has been pinned with the

adjustment wedge in the casting. This has the advantage that the active retraction sits in the same position again after disassembly, and the guide play corresponds exactly to the presetting in terms of repetition. If the sintered surface of the active retractor is worn, it can be adjusted as described under 14.1, the cylindrical pin must then no longer be used.

If the active return is replaced by a new component, it must also be adjusted as described under 14.1, the cylinder pin must then also no longer be used.

PowerMax cam unit SN5650-PMO-0330 — SN5650-PMO-1200

13.2 Einstellung des Zwangsrückzuges

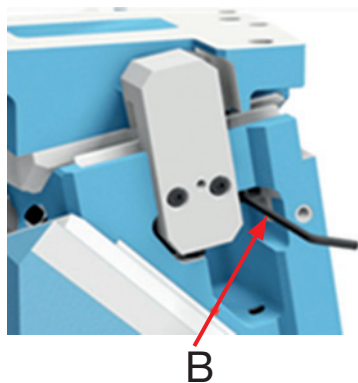
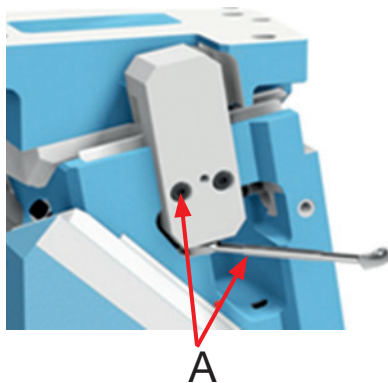

Place the cam retainer with the cam slide on the head side of the cam retainer to guarantee a firm stand.

Loosen the pin and the fixing screws of the active returns (A) and the adjustment wedge (B).

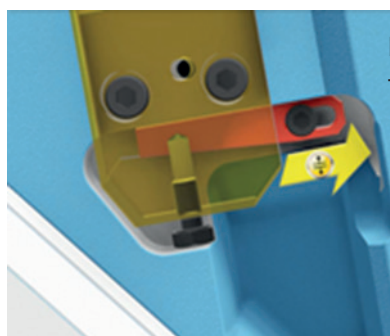

Pull back the adjustment wedge and place the driver on the prism of the cam slide.

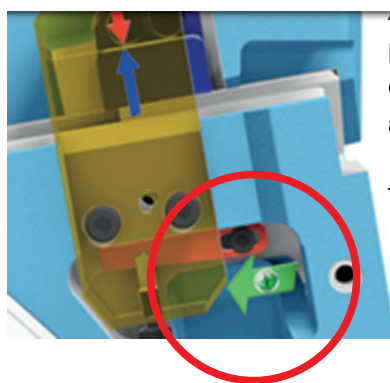

After placing the driver on the cam slide press the active returns onto the inserts of the driver and fix them by moving the adjustment wedge in direction of the arrow.

Then fasten the screws in reverse order.

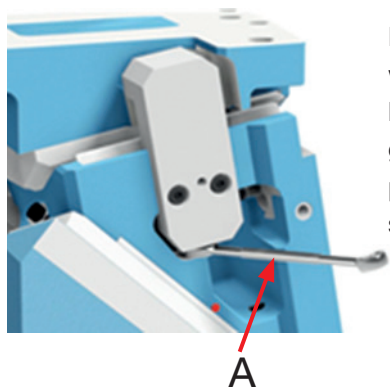
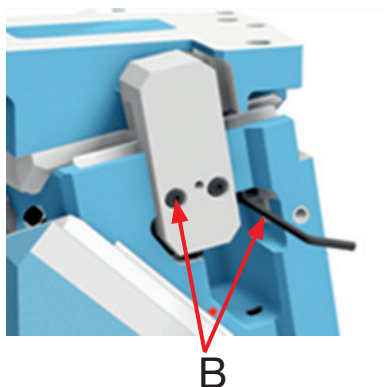

Fix the fastening screws of the adjustment wedges and the active returns (B), then lock the active return (A) and check the guide play with 0,01 mm gauge tape. To prevent the driver from tilting both sides should be tightened equally.

PowerMax cam unit SN5650-PMO-0065 — SN5650-PMO-0260

13.3 Lubrication

Guiding elements out of SNS-sintered metal characterize by the follow features:

- Significant increase in service life minimizes your maintenance costs
- High durability increases your productivity
- High temperature resistance until 250 ° ensures your flexibility
- Favourable and constant purchase prices save your money

The requirements of modern toolmaking have changed.

To meet these requirements, a new sintered metal has been developed as slide bearing material. This SNS sintered metal absorbs the stresses caused by the machining of high-strength sheet metal. At the same time, maintenance friendliness and service life are increased.

The new generation of bearing elements is an iron-based porous sintered metal. This characterizes by a long bearing mileage at medium to high speeds. The sintered metal is applied to a steel base body which gives the guide element a higher strength.

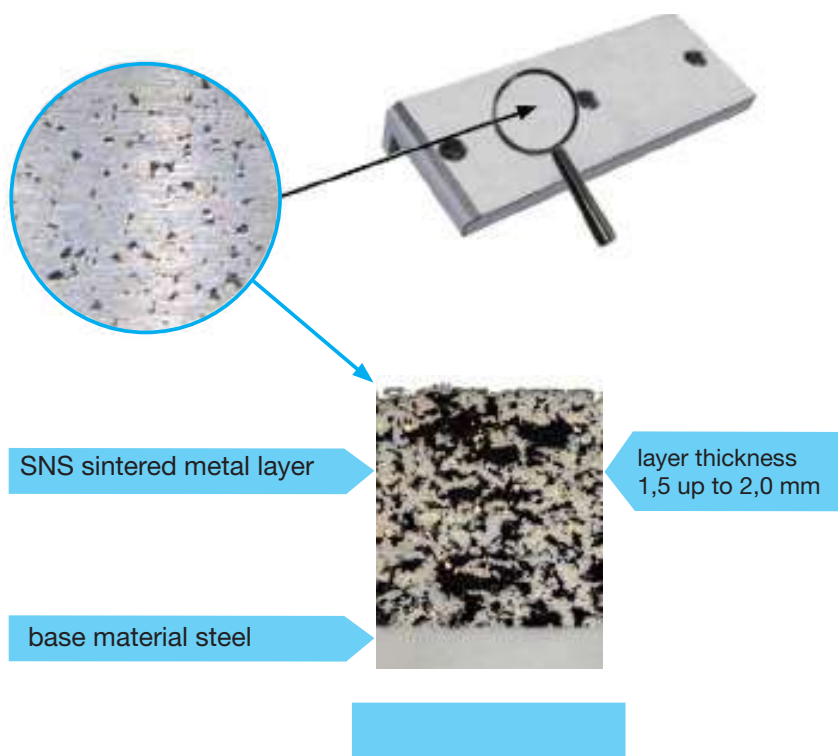

PowerMax cam unit SN5650-PMO-0330 — SN5650-PMO-1200

SNS Sintermetall
SNS sintered metal
Métal fritté SNS

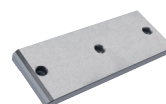

Maximale Gleitgeschwindigkeit / Maximal sliding speed /
 Vitesse de glissement maximale

40 m/min trocken / dry / sec
 80 m/min geschmiert / lubricated / lubrifié

Reibungskoeffizient / Frictional coefficient /
 Coefficient de frottement

0,05 - 0,15

PV Wert / PV-value / Valeur PV

2950 daN/cm² x m/min

Flächenpressung max. / Surface pressure
 max. /
 Pression superficielle maximale

76 N/mm²

Arbeitstemperatur / Operating temperature /
 Température de travail

< 250 °C trocken / dry / sec
 < 150 °C geschmiert / lubricated / lubrifié
 (in Abhängigkeit vom verwendeten Schmierstoff /
 dependent from the used lubrication / dépendant
 de la lubrification utilisée)

Porösität der Sintergleitfläche / Porosity of the
 sinter sliding surface /
 Porosité de la surface de glissement frittée

15 - 25 %

Integrierter Schmierstoff / Integrated lubricant
 / Lubrifiant intégré

Fe+Cu+Graphit+MoS₂

Schmierstoffanteil / Portion of lubricant / Part
 du lubrifiant

15 - 20 %

PowerMax cam unit SN5650-PMO-0065 — SN5650-PMO-0260

SNS-sintered metal slide elements are maintenance friendly. During normal operation no additional maintenance measures are necessary. However, influences as cleaning of the tools or sealings, which are carried out for transport can change the properties. In this case, additional lubrication of SNS sintered sliding elements increases the service life significantly.

An additional lubrication with an oil Z9084 reduces the friction heat and the wear significantly. The service life is also increased by reducing the number of abrasion particles and avoidance due to foreign particle influence (sealing effect). The lubrication reduces the noise generation and increases the corrosion protection effect.

In delivered condition all SNS-guiding elements are impregnated with oil Z9084. This, additionally, reduces drastic wear occurring during the initial operation.

According to the following operating instructions an additional lubrication is recommended.

For optimal running performance we recommend the following oil:

Lubricant	max.°C	<i>Further information in Annex 15.2</i>
STRACK Z9084	130	

The relubrication intervals must be adapted to the operating conditions. All SNS-bearings should always be relubricated as part of normal tool maintenance.

Alternative recommendations optimal (if STRACK lubricants are not available):

Company	oils	max.°C	Fette	max.°C
AGIP	Rotra ATF	100	Agip GR MU 2	120
BP	Autran DX III	100	Energrease	140
ESSO / Mobil	ATF 320	100	Nebula EP2	120
ESSO / Mobil	ATF 220	100	Beacon EP2	130
Castrol	ATF DEX II	100	Tribol GR 4020 PD	150
SHELL	Spirax S1 ATF TASA	80	Retinax LX	140

PowerMax cam unit SN5650-PMO-0330 — SN5650-PMO-1200

14. Appendix

14.1 Internet and CAD

The company STRACK NORMA has created an online presence for the PowerMax cam elements which is tailored to the requirements of the constructing engineers.

By using the link www.strack.de you can reach the corresponding homepage.

PowerMax cam unit SN5650-PMO-0330 — SN5650-PMO-1200

14.2 Lubricant Z9084

Synthetischer Schmierstoff für SNS-Führungselemente



Z9084

Basis: organischer Ester

I

0,5

1,0

20,0



Z9084-I



Synthetischer Schmierstoff für SNS-Führungselemente

Technische Daten:

Form	flüssig
Dichte (15°C) DIN 51757	0,920 kg/l
Konsistenzgeber	anorganisch
ISO Viskositätsklasse	68
SAE Viskositätsklasse	30
Viskosität bei 40°C	62,1 mm ² · s ⁻¹
Viskosität bei 100°C	11,4 mm ² · s ⁻¹
Viskositätsindex	180
Optimaler Einsatztemperaturbereich	-35 °C - +130 °C
Stockpunkt	-54 °C
Flammpunkt COC	246 °C
Verdampfungsverlust 22h, 99°C	0,8 %

Einsatzbereiche:

- Tränkung von Sinterlagern
- Reibungsarme Lager
- Manuelle oder automatische Schmierstoffzufuhr
- Umlaufschmierung
- Druckschmierung

Das Produkt hat keine negativen Auswirkungen auf Dichtungen, Kunststoffe und Anstriche aus Viton, Teflon, Perbunan mit einem Acrylnitrilgehalt >30 %, Epoxidharzlacke, ölbeständige Alkydharze, Polyamide, PET, PBT.

Nicht empfehlenswert sind Neopren, SBR, Perbunan mit einem Acrylnitrilgehalt <30 %, Acryllacke, PVC, ABS.









Nicht mit anderen Schmierstoffen mischen!

Eigenschaften:

- Hoher Viskositätsindex
- ISO VG 5 bis 100
- Breites Betriebstemperaturspektrum
- Hohe thermische, oxidative und chemische Stabilität
- Ausgezeichnete Kondensatabscheidung
- Gutes Detergier- und Dispergierverhalten
- Keine Neigung zu Bildung von ölbedingten Rückständen oder Ablagerungen
- Gute Produktverträglichkeit mit den Werkstoffen im modernen Maschinenbau
- Keine Schaumbildung
- Höhere kritische Temperaturen (ca. 40 - 60 °C)
- Höhere Flammpunkte und Selbstentzündungstemperaturen als Mineralöle
- Hohe Polarität
- Hohe Scherstabilität
- Ausgezeichneter Verschleißschutz
- Hoher Korrosionsschutz

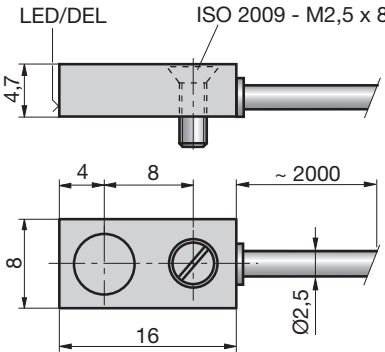
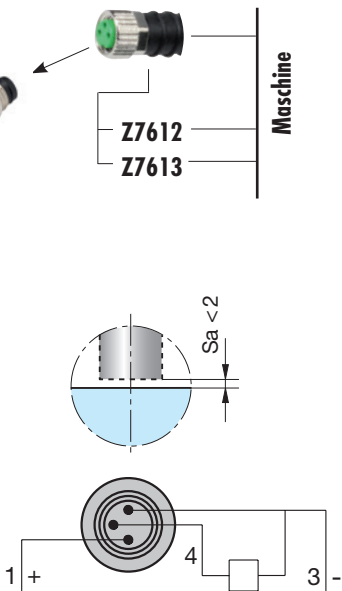
PowerMax cam unit SN5650-PMO-0330 — SN5650-PMO-1200

14.3 Limit switch Z7685

Endschalter	Limit switch	Contacteur de fin de course
 <p>Sa = Arbeitsschaltabstand. Sa = Work-switching gap. Sa = L'intervalle de communication de travail.</p> <p>1 = bn = braun/brown/brun 3 = bl = blau/blue/bleu 4 = sw = schwarz/black/noir</p>	 	
<p>Z7685</p>		
 <p>Z7685</p>	 	

- Temperaturbeständigkeit bis 75 °C.
- Spritzwassergeschützt nach IP 67.
- Arbeitsschaltabstand 2 mm.

- Berührungslos durch Präzisionsensorik.
- Endlose Wiederholgenauigkeit.
- Kein Verschleiß.
- Feinsteinstellung durch optische Anzeige (LED) und Z7608.
- Betriebsspannung 10 - 30 V DC.
- Strombelastbarkeit 100 mA.
- PNP-Schließer.
- Anschluss über Z7621 an die Maschinensteuerung.
- Beim Einsatz mehrerer Endschalter, die gleichzeitig geschaltet werden müssen, ist das Anschlussgehäuse Z7614 erforderlich.

- Thermal endurance up to 75 °C.
- Splash-proof to IP 67.
- Work-switching gap 2 mm.

- Contactless through precisions sensor technology.
- Infinite repeat accuracy.
- No wear.
- Fine adjustment via optical display (LED) and Z7608.
- Operating voltage 10 - 30 V DC.
- Current-carrying capacity 100 mA.
- PNP make contact.
- Connection to the machine control system via Z7621.
- Connection housing Z7614 must be used if several limit switches have to be switched simultaneously.

- Tenue en température constante jusqu'à 75 °C.
- Protection contre les projections d'eau selon le type de protection IP 67.
- L'intervalle de communication du travail 2 mm.

- Sans contact grâce à la technique sensorielle.
- Reproduction exacte en fonctionnement continu.
- Pas de verrouillage.
- Réglage de la position du capteur par vis.
- Réglage fin grâce à l'indicateur optique (DEL) et Z7608.
- Tension de fonctionnement 10 - 30 V DC.
- Charge de courant maximale: 100 mA
- PNP contact à fermeture.
- Raccordement par la prise du Z7621 à la commande de la machine.
- Lorsque plusieurs contacteurs de fin de course doivent être commutés en même temps, utiliser impérativement le boîtier de raccordement Z7614.

PowerMax cam unit SN5650-PMO-0330 — SN5650-PMO-1200

14.4 General description of gas springs

GAS SPRINGS

The gas springs are developed and produced based on the long experience in the nitrogen gas spring research and development.

We understand that the final quality of our product is the individual quality of all

its parts, and we therefore painstakingly check each and every one of them.

All the components are subjected to visual and dimensional inspection prior to assembly.

100 % of the gas springs are subjected to dynamic and static gas-proof testing.

All STRACK gas springs, thanks to their design, admit maintenance in a quick and simple manner.

Most STRACK gas springs have a one-piece construction in all their components, thus eliminating risks of breakage due to material fatigue and therefore also

eliminating possible leakage points.

All STRACK gas springs are supplied with a quality certificate.

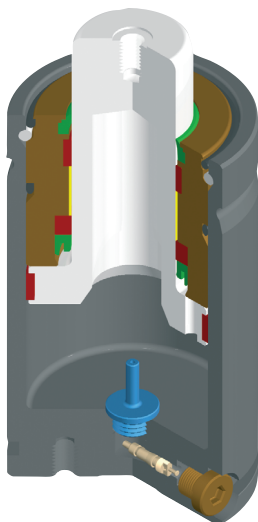

COMPONENT CHARACTERISTICS

Body

Developed in one piece up to strokes of 125 mm. In higher strokes they have a tubular construction with a welded lid. As a difference with other brands, STRACK incorporates a threaded joint between the two elements that eliminates the possible fatigue factor in the weld bead.

Stem

Fatigue-resistant steels are employed, which have specific treatments that ensure a long useful life. STRACK offers the maximum quality MICROFINISH on the surface of all its stems, thus ensuring a longer service life by reducing friction and wear and tear in the seals..

Bushing

It incorporates a scraper, an element that avoids the entrance of filth. All bushings are designed avoiding a metal-to-metal contact, recurring to self-lubricating guiding elements. Reference to gastightness, specific seals are used, which have been painstakingly tested and which offer a high working yield even near their maximum limits of use.

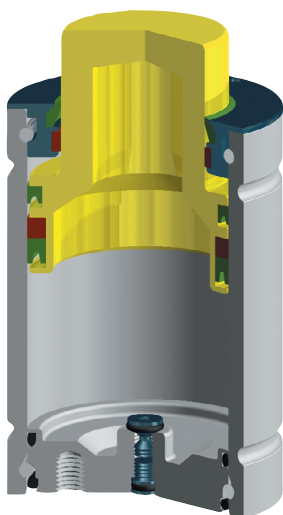

PowerMax cam unit SN5650-PMO-0330 — SN5650-PMO-1200

14.5 Maximal operating conditions for gas springs

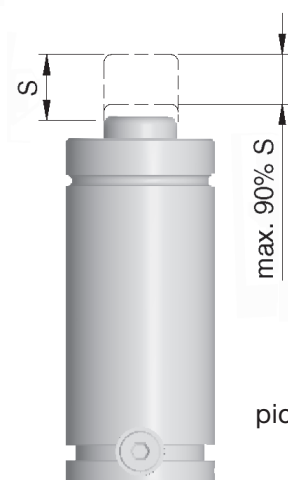
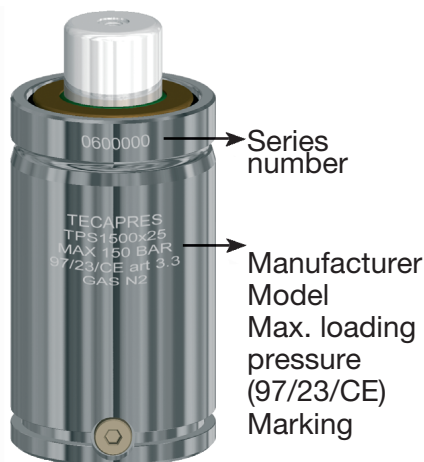

picture 1

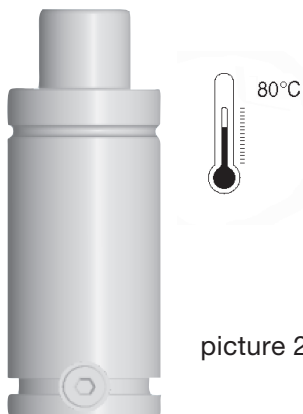

picture 2

Identification

All STRACK gas springs are clearly identified by means of a consistent engraving on the body in accordance with the specification of the European norm (97/23/CE).

Working stroke

The working stroke is maintained invariable during use thanks to a mechanical stop. All STRACK gas springs can work using the whole of their nominal stroke (S) as all models have a stroke reserve. However, in order to reach an optimal service life, it is convenient to design with an optimal safety level. It is therefore recommended to foresee a 10 % stroke reserve. (picture 1)

Working temperature

Maximum working temperature is 80°C. Higher temperatures can damage the gastightness elements, and seriously affect the length of the gas spring service life. (picture 2)

Maximum filling pressure

You should never go over the maximum loading pressure for each gas spring, which is between 150 and 175 bar (at 20°C) depending on each model. Maximum loading pressure is detailed in each model's technical specifications.

Maximum working speed

Maximum lineal working stem speed is variable depending on the type of gas spring. Maximum working speeds are detailed in each model's technical specifications.

Maximum rate

The calculation of maximum rate per minute (N) is calculated following this formula:

$$N = \frac{K}{(2 \times S) + 50}$$

K = Calculation coefficient
(values detailed in the technical specifications for each model)
S = Working stroke

PowerMax cam unit SN5650-PMO-0330 — SN5650-PMO-1200

14.6 Calculations gas springs

Initial force

Gas spring initial force is calculated in relation with the working surface and loading force in accordance with the following formula:

$$F_i = A \times P$$

F_i = Initial nominal force in daN
 A = Working area in cm² (as detailed in the specifications of each model)
 P = Loading pressure in Bar

Variation of the initial force

Loading pressure may be modified to vary the initial force of a gas spring.

If we know the initial force, we can use the following formula:

$$P = P_i \times \frac{F}{F_i}$$

P = Pressure wanted (Bar), P_i = Gas spring nominal loading pressure (Bar)
 F = Required initial force (daN), F_i = Gas spring nominal initial force (daN)

Variation of forces depending on the temperature

Gas temperature affects the pressure of gas springs and therefore also their force. The forces specified in the catalogue correspond to loading pressures at a temperature of 20°C. In the temperature/pressure graph it is possible to see how nitrogen pressure varies according to the temperature.

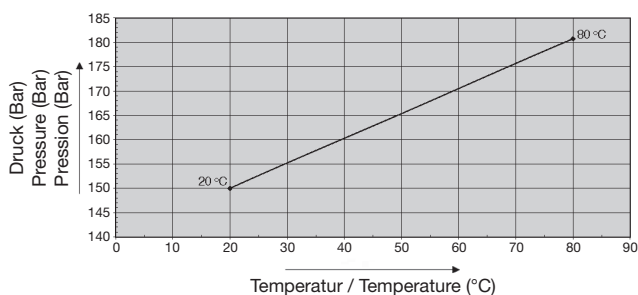

Technical advice

With the purpose of helping our customers we have a technical advice service. By means of this service, you will receive advice from specialised technicians, and all your queries will be answered. We will help you choose the most adequate product depending on the type of work you wish to carry out.

Guarantee and duration

The guarantee that STRACK offers in gas springs is for one year as from the date of acquisition, or the equivalent to a stem lineal displacement of 100,000 metres in gas springs with strokes equal to or over 25 mm. whereas in gas springs with shorter strokes the guarantee is of 2,000,000 cycles. The guarantee (which covers parts and labour costs) is applicable if and when the following conditions are fulfilled:

1. The gas springs does not present defects due to dents (blows, scratches, welding detachments, rust and so on..).
2. Their application and use has been strictly within the limits of the technical conditions specified, and of the various applicable recommendations.
3. The gas spring has not been manipulated (opening the gas spring cancels the guarantee).

PowerMax cam unit SN5650-PMO-0330 — SN5650-PMO-1200

14.7 Mounting instructions gas springs



A 10 % nominal stroke reserve should be foreseen to prevent irreparable damage in the gas springs and serious safety hazards.

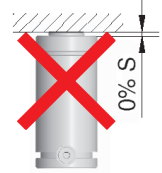

If possible fix the gas spring on the tool using the attachment holes at the bottom of the body or assembly accessories.

Do not use threaded hole on the stem to fix the gas spring onto the tool.



Do not install the gas spring onto the tool in such a way it makes

a free stem ejection possible. The installation of a compressed gas spring is dangerous due to serious safety risks.

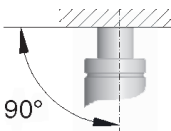
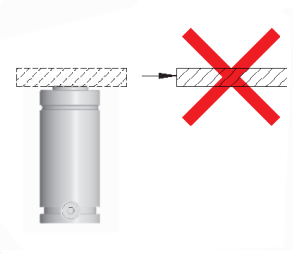

The gas spring is to work completely perpendicularly to the contact surface. Lateral forces reduce the gas spring's service life.

Protect the gas spring from direct contact with liquid pollution: lubricants, cleaners and so on..

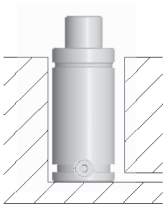

Protect the gas spring against mechanical damage or blows, especially the stem. Any imperfection may bring about a loss of pressure.

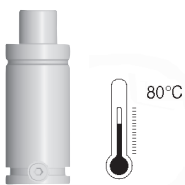
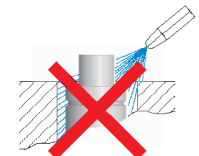

Service temperature should not exceed 80°C.

Higher temperatures will affect the seals, reducing the gas spring's service life.



Do not exceed maximum filling pressures established for each Gas spring.

Higher pressures will reduce both the gas spring service life and endanger its use.

PowerMax cam unit SN5650-PMO-0330 — SN5650-PMO-1200

14.8 Fülldrucktabelle Gasdruckfedern

Gasdruckfedern Gas springs Ressorts à gaz	Fülldruck in bar / Filling pressure in bar / Pression de remplissage en bar																	F max. [daN]	P max. [bar]		
	Nenndruck / Nominal pressure Pression nominale Nennkraft / Nominal force Force nominale			A	30	40	50	60	70	80	90	100	110	120	130	140	150			160	170
	P [bar]	F [daN]	A	Zylinderkraft in daN bei Fülldruck in bar Cylinder force in daN at filling pressure in bar Force du cylindre en daN à pression de remplissage en bar																	
SN2800-42	150	42	0,28	8	11	14	17	20	22	25	28	31	34	36	39	42			42	150	
SN2800-50	175	50	0,28	8	11	14	17	20	22	25	28	31	34	36	39	42	45	48	49	175	
SN2800-100	175	90	0,50	15	20	25	30	35	40	45	50	55	60	65	70	75	80	85	88	175	
SN2800-200	175	200	1,13	34	45	57	68	79	90	102	113	124	136	147	158	170	181	192	198	175	
SN2803-90	175	90	0,50	15	20	25	30	35	40	45	50	55	60	65	70	75	80	85	88	175	
SN2803-200	175	200	1,13	34	45	57	68	79	90	102	113	124	136	147	158	170	181	192	198	175	
SN2805-90	175	90	0,50	15	20	25	30	35	40	45	50	55	60	65	70	75	80	85	88	175	
SN2805-25-200	175	200	1,13	34	45	57	68	79	90	102	113	124	136	147	158	170	181	192	198	175	
SN2805-300	150	300	2,01	60	80	101	121	141	161	181	201	221	241	261	281	302			312	155	
SN2805-450	175	450	2,54	76	102	127	152	178	203	229	254	279	305	330	356	381	406	432	445	175	
SN2807-500	190	500	2,54	76	102	127	152	178	203	229	254	279	305	330	356	381	406	432	508	200	
SN2807-750	190	750	3,80	114	152	190	228	266	304	342	380	418	456	494	532	570	608	646	760	200	
SN2807-920	150	920	6,16	185	246	308	370	431	493	554	616	678	739	801	862	924			924	150	
SN2807-1200	150	1200	8,04	241	322	402	482	563	643	724	804	884	965	1045	1126	1206			1206	150	
SN2807-2100	150	2100	13,85	416	554	693	831	970	1108	1247	1385	1524	1662	1801	1939	2078			2078	150	
SN2807-3000	150	3000	19,63	589	785	982	1178	1374	1570	1767	1963	2159	2356	2552	2748	2945			2945	150	
SN2808-90	175	90	0,50	15	20	25	30	35	40	45	50	55	60	65	70	75	80	85	88	175	
SN2808-V-170	175	170	0,95	29	38	48	57	67	76	86	95	105	114	124	133	143	152	162	166	175	
SN2808-275	175	275	1,54	46	62	77	92	108	123	139	154	169	185	200	216	231	246	262	270	175	
SN2808-H-275	175	275	1,54	46	62	77	92	108	123	139	154	169	185	200	216	231	246	262	270	175	
SN2808-R-275	175	275	1,54	46	62	77	92	108	123	139	154	169	185	200	216	231	246	262	270	175	
SN2808-V-350	175	350	2,01	60	80	101	121	141	161	181	201	221	241	261	281	302	322	342	352	175	
SN2808-VS-350	175	350	2,01	60	80	101	121	141	161	181	201	221	241	261	281	302	322	342	352	175	
SN2808-C-350	175	350	2,01	60	80	101	121	141	161	181	201	221	241	261	281	302	322	342	352	175	
SN2808-450	175	450	2,54	76	102	127	152	178	203	229	254	279	305	330	356	381	406	432	445	175	
SN2808-H-450	175	450	2,54	76	102	127	152	178	203	229	254	279	305	330	356	381	406	432	457	175	
SN2808-R-450	175	450	2,54	76	102	127	152	178	203	229	254	279	305	330	356	381	406	432	457	175	
SN2808-V-470	150	470	3,14	94	126	157	188	220	251	283	314	345	377	408	440	471			471	150	
SN2808-VS-470	150	470	3,14	94	126	157	188	220	251	283	314	345	377	408	440	471			471	150	
SN2808-660	175	660	3,80	114	152	190	228	266	304	342	380	418	456	494	532	570	608	646	665	175	
SN2808-H-660	175	660	3,80	114	152	190	228	266	304	342	380	418	456	494	532	570	608	646	684	175	
SN2808-R-660	175	660	3,80	114	152	190	228	266	304	342	380	418	456	494	532	570	608	646	684	175	
SN2808-800	150	800	4,90	147	196	245	294	343	392	441	490	539	588	637	686	735			735	150	
SN2808-V-800	150	740	4,91	147	196	246	295	344	393	442	491	540	589	638	687	737			737	150	
SN2808-920	150	920	6,16	185	246	308	370	431	493	554	616	678	739	801	862	924			924	150	
SN2808-VS-920	150	920	6,16	185	246	308	370	431	493	554	616	678	739	801	862	924			924	150	
SN2808-C-1100	160	1100	7,07	212	283	354	424	495	566	636	707	778	848	919	990	1061	1131		1131	160	

Näherungswerte, Abweichungen möglich / Approximate values, tolerances possible / Valeurs approchées, tolérances possibles

PowerMax cam unit SN5650-PMO-0330 — SN5650-PMO-1200

Fülldrucktabelle Gasdruckfedern

Gasdruckfedern Gas springs Ressorts à gaz	Fülldruck in bar / Filling pressure in bar / Pression de remplissage en bar																		F max. [daN]	P max. [bar]
	Nenndruck / Nominal pressure Pression nominale Nominal force																			
	P [bar]	F [daN]	A	30	40	50	60	70	80	90	100	110	120	130	140	150	160	170		
	Zylinderkraft in daN bei Fülldruck in bar Cylinder force in daN at filling pressure in bar Force du cylindre en daN à pression de remplissage en bar																			
SN2808-V-1100	160	1100	7,07	212	283	354	424	495	566	636	707	778	848	919	990	1061	1131		1131	160
SN2808-C-1500	150	1500	10,18	305	407	509	611	713	814	916	1018	1120	1222	1323	1425	1527			1527	150
SN2808-V-1500	150	1500	10,18	305	407	509	611	713	814	916	1018	1120	1222	1323	1425	1527			1527	150
SN2808-1900	150	1900	12,57	377	503	629	754	880	1006	1131	1257	1383	1508	1634	1760	1886			1886	150
SN2808-2400	150	2400	15,90	477	636	795	954	1113	1272	1431	1590	1749	1908	2067	2226	2385			2385	150
SN2808-4250	150	4250	28,27	848	1131	1414	1696	1979	2262	2544	2827	3110	3392	3675	3958	4241			4241	150
SN2808-6600	150	6600	44,18	1325	1767	2209	2651	3093	3534	3976	4418	4860	5302	5743	6185	6627			6627	150
SN2808-V-6600	150	6600	44,18	1325	1767	2209	2651	3093	3534	3976	4418	4860	5302	5743	6185	6627			6627	150
SN2808-9500	150	9500	63,62	1909	2545	3181	3817	4453	5090	5726	6362	6998	7634	8271	8907	9543			9543	150
SN2808-20000	150	20000	132,73	3982	5309	6637	7964	9291	10618	11946	13273	14600	15928	17255	18582	19910			19910	150
SN2809-200	175	200	1,13	34	45	57	68	79	90	102	113	124	136	147	158	170	181	192	198	175
SN2809-R-200	175	200	1,13	34	45	57	68	79	90	102	113	124	136	147	158	170	181	192	198	175
SN2809-400	155	400	2,54	76	102	127	152	178	203	229	254	279	305	330	356	381			394	155
SN2809-600	155	600	3,80	114	152	190	228	266	304	342	380	418	456	494	532	570			589	155
SN2809-750	150	750	4,90	147	196	245	294	343	392	441	490	539	588	637	686	735			735	150
SN2809-1000	142	1000	7,07	212	283	354	424	495	566	636	707	778	848	919	990	1061			1061	150
SN2809-1500	148	1500	10,17	305	407	509	610	712	814	915	1017	1119	1220	1322	1424	1526			1526	150
SN2809-3000	150	3000	19,63	589	785	982	1178	1374	1570	1767	1963	2159	2356	2552	2748	2945			2945	150
SN2820-200	175	200	1,13	34	45	57	68	79	90	102	113	124	136	147	158	170	181	192	198	175
SN2820-250	142	250	1,77	53	71	89	106	124	142	159	177	195	212	230	248	266			266	150
SN2820-P-300	150	300	2,01	60	80	101	121	141	161	181	201	221	241	261	281	302	322	342	302	150
SN2820-500	150	470	3,14	94	126	157	188	220	251	283	314	345	377	408	440	471			471	150
SN2820-P-500	150	500	3,14	94	126	157	188	220	251	283	314	345	377	408	440	471			471	150
SN2820-750	150	740	4,90	147	196	245	294	343	392	441	490	539	588	637	686	735			735	150
SN2820-C-750	150	740	4,91	147	196	246	295	344	393	442	491	540	589	638	687	737			737	150
SN2820-P-750	150	740	3,14	94	126	157	188	220	251	283	314	345	377	408	440	471			471	150
SN2820-P-1000	142	1000	7,07	212	283	354	424	495	566	636	707	778	848	919	990	1061			1061	150
SN2820-1500	148	1500	10,17	305	407	509	610	712	814	915	1017	1119	1220	1322	1424	1526			1526	150
SN2820-C-1500	148	1500	10,18	305	407	509	611	713	814	916	1018	1120	1222	1323	1425	1527			1527	150
SN2820-P-2400	150	2400	15,90	477	636	795	954	1113	1272	1431	1590	1749	1908	2067	2226	2385			2385	150
SN2820-3000	150	3000	19,63	589	785	982	1178	1374	1570	1767	1963	2159	2356	2552	2748	2945			2945	150
SN2820-C-3000	150	3000	19,63	589	785	982	1178	1374	1570	1767	1963	2159	2356	2552	2748	2945			2945	150
SN2820-P-4200	150	4200	28,27	848	1131	1414	1696	1979	2262	2544	2827	3110	3392	3675	3958	4241			4241	150
SN2820-5000	150	5000	31,18	935	1247	1559	1871	2183	2494	2806	3118	3430	3742	4053	4365	4677			4677	150
SN2820-C-5000	150	5000	33,18	995	1327	1659	1991	2323	2654	2986	3318	3650	3982	4313	4645	4977			4977	150
SN2820-P-6600	147	6600	44,18	1325	1767	2209	2651	3093	3534	3976	4418	4860	5302	5743	6185	6627			6627	150
SN2820-7500	150	7500	50,26	1508	2010	2513	3016	3518	4021	4523	5026	5529	6031	6534	7036	7539			7539	150

Näherungswerte, Abweichungen möglich / Approximate values, tolerances possible / Valeurs approchées, tolérances possibles

PowerMax cam unit SN5650-PMO-0330 – SN5650-PMO-1200

Fülldrucktabelle Gasdruckfedern

Gasdruckfedern Gas springs Ressorts à gaz	Fülldruck in bar / Filling pressure in bar / Pression de remplissage en bar																	F max. [daN]	P max. [bar]	
	Zylinderkraft in daN bei Fülldruck in bar Cylinder force in daN at filling pressure in bar Force du cylindre en daN à pression de remplissage en bar																			
	Nenn- druck / Nominal pression [bar]	Nenn- kraft / Nominal force [daN]	A	30	40	50	60	70	80	90	100	110	120	130	140	150	160			170
SN2820-C-7500	150	7500	50,27	1508	2011	2514	3016	3519	4022	4524	5027	5530	6032	6535	7038	7541			7541	150
SN2820-P-9500	150	9500	63,62	1909	2545	3181	3817	4453	5090	5726	6362	6998	7634	8271	8907	9543			9543	150
SN2820-A-10000	141	10000	70,88	2126	2835	3544	4253	4962	5670	6379	7088	7797	8506	9214	9923	10632			10632	150
SN2820-C-10000	141	10000	70,88	2126	2835	3544	4253	4962	5670	6379	7088	7797	8506	9214	9923	10632			10632	150
SN2825-750	150	750	4,91	147	196	246	295	344	393	442	491	540	589	638	687	736			737	150
SN2825-1250	175	1250	7,07	212	283	354	424	495	566	636	707	778	848	919	990	1061	1131	1202	1237	175
SN2825-1500	148	1500	10,18	305	407	509	611	713	814	916	1018	1120	1222	1323	1425	1527			1527	150
SN2825-1800	175	1800	10,18	305	407	509	611	713	814	916	1018	1120	1222	1323	1425	1527	1629	1731	1782	175
SN2825-3000	150	3000	19,63	589	785	982	1178	1374	1570	1767	1963	2159	2356	2552	2748	2945			2945	150
SN2825-5000	150	5000	33,18	995	1327	1659	1991	2323	2654	2986	3318	3650	3982	4313	4645	4977			4977	150
SN2830-350	138	350	2,54	76	102	127	152	178	203	229	254	279	305	330	356	381			381	150
SN2830-500	132	500	3,80	114	152	190	228	266	304	342	380	418	456	494	532	570			570	150
SN2830-1000	142	1000	7,06	212	282	353	424	494	565	635	706	777	847	918	988	1059			1059	150
SN2830-1500	148	1500	10,17	305	407	509	610	712	814	915	1017	1119	1220	1322	1424	1526			1526	150
SN2900-420	133	420	3,14	94	126	157	188	220	251	283	314	345	377	408	440	471			471	150
SN2900-750	150	750	4,90	147	196	245	294	343	392	441	490	539	588	637	686	735			735	150
SN2900-7000	139	7000	50,27	1508	2011	2514	3016	3519	4022	4524	5027	5530	6032	6535	7038	7541			7541	150
SN2900-7500	150	7500	50,26	1508	2010	2513	3016	3518	4021	4523	5026	5529	6031	6534	7036	7539			7539	150
SN2900-11800	150	11800	78,54	2356	3142	3927	4712	5498	6283	7069	7854	8639	9425	10210	10996	11781			11781	150
SN2900-18300	150	18300	122,72	3682	4909	6136	7363	8590	9818	11045	12272	13499	14726	15954	17181	18408			18408	150
SN2901-7500	150	7500	50,26	1508	2010	2513	3016	3518	4021	4523	5026	5529	6031	6534	7036	7539			7539	150
SN2901-11800	150	11800	78,54	2356	3142	3927	4712	5498	6283	7069	7854	8639	9425	10210	10996	11781			11781	150
SN2901-18300	150	18300	122,72	3682	4909	6136	7363	8590	9818	11045	12272	13499	14726	15954	17181	18408			18408	150
SN2902-1000	150	1000	7,07	212	283	354	424	495	566	636	707	778	848	919	990	1061			1061	150
SN2902-1800	142	1800	12,57	377	503	629	754	880	1006	1131	1257	1383	1508	1634	1760	1886			1886	150
SN2902-2000	155	2000	12,57	377	503	629	754	880	1006	1131	1257	1383	1508	1634	1760	1886			1948	155
SN2902-3000	150	3000	19,63	589	785	982	1178	1374	1570	1767	1963	2159	2356	2552	2748	2945			2945	150
SN2902-4700	150	4700	31,17	935	1247	1559	1870	2182	2494	2805	3117	3429	3740	4052	4364	4676			4676	150
SN2910-M16	175	50	0,28	8	11	14	17	20	22	25	28	31	34	36	39	42	45	48	49	175
SN2910-M24	175	140	0,78	23	31	39	47	55	62	70	78	86	94	101	109	117	125	133	137	175
SN2910-M28	175	200	1,13	34	45	57	68	79	90	102	113	124	136	147	158	170	181	192	198	175
SN2910-M38x1.5	142	250	1,77	53	71	89	106	124	142	159	177	195	212	230	248	266			266	150
SN2910-M45	150	750	4,90	147	196	245	294	343	392	441	490	539	588	637	686	735			735	150
SN2910-M50	142	1000	7,06	212	282	353	424	494	565	635	706	777	847	918	988	1059			1059	150

Näherungswerte, Abweichungen möglich / Approximate values, tolerances possible / Valeurs approchées, tolérances possibles

PowerMax cam unit SN5650-PMO-0330 — SN5650-PMO-1200

15. Exploded view and item list

On the following pages you will find an exploded view and an item list (exemplary) like it can be downloaded on the internet side of the PowerMax cam (www.strack.de)

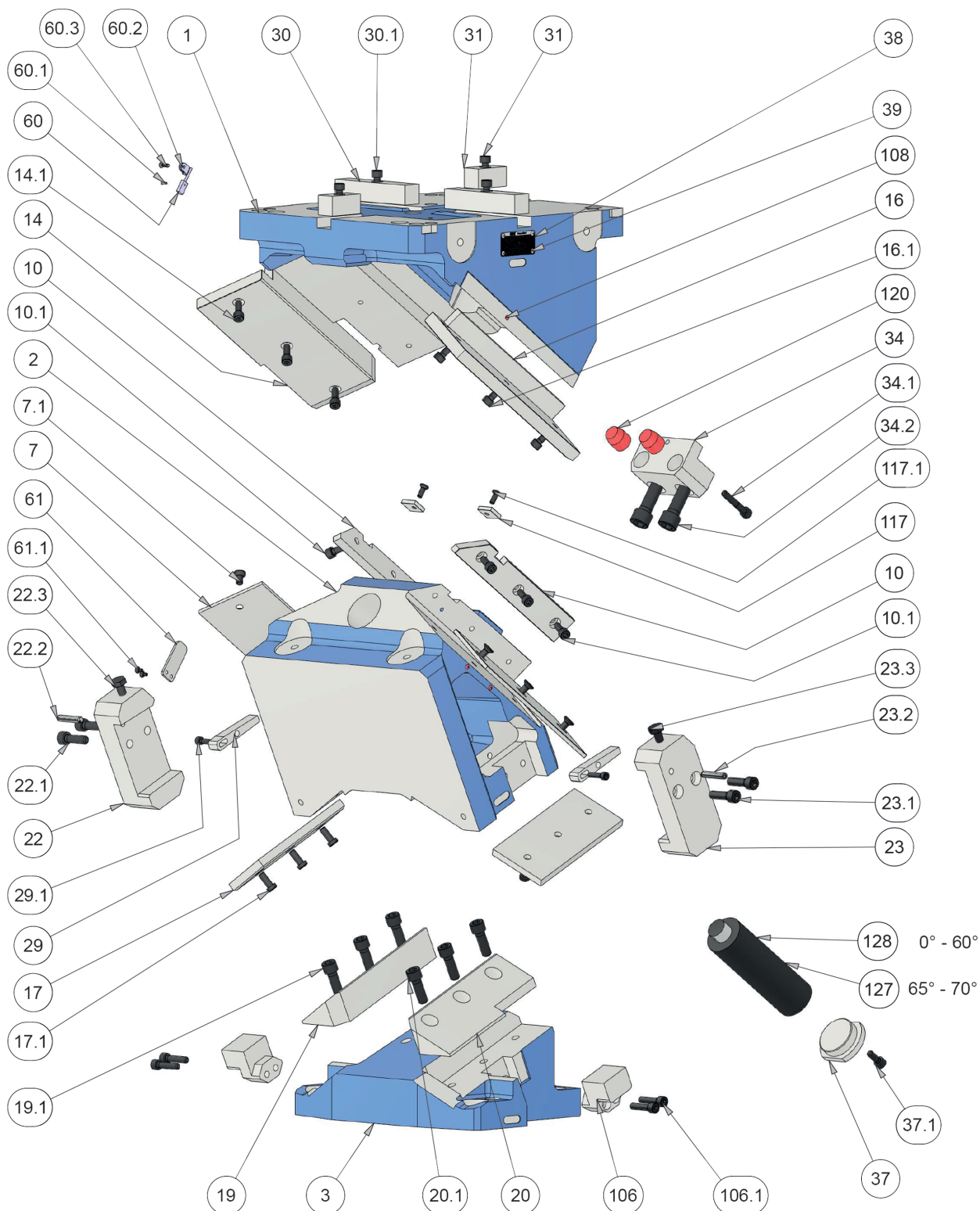

PowerMax cam unit SN5650-PMO-0330 — SN5650-PMO-1200

Teil: 511050
Bezeichnung: SN5650-PMO-0330-25-E0-G0-S1-V04

Änderungsdatum: 01.06.2022

Seite: 2 von 3

Pos.	Stk.	Bezeichnung	Art. Nr.
1	1	SN5650-PMO-SAF-0330-25-V05 Schieberaufnahme Fertigteil / Slide retainer, machined part	501358
2	1	SN5650-PMO-SKF-0330-25-V05 Schieberkörper Fertigteil / Slide retainer, machined part	501359
3	1	SN5650-PMO-TF-0330-25-V05 Treiber Fertigteil / Driver unit, machined part	501360
7	2	SN5650-PM-BS-T6-0-V03 Beplankung Schieberbett / Planking slidebed	223343
7.1	6	SN3550-M8-25 Senkkopfschraube / Countersunk head screw	62646
10	1	SN5650-PMO-BSSL-T3-0-V04 Bepl. Schieberbett links / Planking sliding bed left	223352
10.1	3	SN3500-M8-20 Zylinderschraube / Socket head screw	62808
11	1	SN5650-PMO-BSSR-T3-0-V04 Bepl. Schieberbett rechts / Planking sliding bed right	223363
11.1	3	SN3500-M8-20 Zylinderschraube / Socket head screw	62808
14	1	SN5650-PM-GSA1-P-T6-V02 Gleitplatte Schieberaufnahme links / Guideplate slide retainer left	112038
14.1	3	SN3500-M8-20 Zylinderschraube / Socket head screw	62808
16	1	SN5650-PM-GSA2-P-T6-V02 Gleitplatte Schieberaufnahme rechts / Guideplate slide retainer right	112040
16.1	3	SN3500-M8-20 Zylinderschraube / Socket head screw	62808
17	2	SN5650-PMO-GST-P-T5-V02 Gleitplatte Schieber-Treiber / Guideplate slider-driver	112056
17.1	6	SN3540-M8-20 Zylinderschraube / Socket head screw	62607
19	1	SN5650-PMO-GTL-T6-20-V01 Gleitstück Treiber links / Guidepiece driver left	223166
19.1	3	SN3500-M12-35 Zylinderschraube / Socket head screw	62848
20	1	SN5650-PMO-GTR-T2-20-V01 Gleitstück Treiber rechts / Guidepiece driver right	223175
20.1	3	SN3500-M12-35 Zylinderschraube / Socket head screw	62848
22	1	SN5650-PMO-ZWL-P-T6-V02 Zwangsrückzug links / Active return left	223434
22.1	2	SN3500-M10-35 Zylinderschraube / Socket head screw	62828
22.2	1	SN1975-8-40 Zylinderstift / Dowel pin	62525
22.3	1	SN3560-M10-20 Sechskantschraube / Hexagon head screw	624636
23	1	SN5650-PMO-ZWR-P-T6-V02 Zwangsrückzug rechts / Active return right	223428
23.1	2	SN3500-M10-35 Zylinderschraube / Socket head screw	62828
23.2	1	SN1975-8-40 Zylinderstift / Dowel pin	62525
23.3	1	SN3560-M10-20 Sechskantschraube / Hexagon head screw	624636
29	2	SN5650-PM-KEZ-T5-V02 Keil Zwangsrückzug / Key active return	10008342
29.1	0	SN3500-M12-120 Zylinderschraube / Socket head screw	62860
29.2	2	SN3500-M6-25 Zylinderschraube / Socket head screw	62790
29.3	1	SN3500-M12-70 Zylinderschraube / Socket head screw	62855

PowerMax cam unit SN5650-PMO-0330 — SN5650-PMO-1200

Teil: 511050
Bezeichnung: SN5650-PMO-0330-25-E0-G0-S1-V04

Änderungsdatum: 01.06.2022

Seite: 3 von 3

Pos.	Stk.	Bezeichnung		Art. Nr.
29.4	1	SN3500-M12-45	Zylinderschraube / Socket head screw	62850
30	2	SN5650-PM-PS1-T3-V02	Passfeder1 / Fitting key 1	10008582
30.1	2	SN3500-M8-30	Zylinderschraube / Socket head screw	62810
31	2	SN5650-PM-PS2-T3-V02	Passfeder2 / Fitting key 2	10008578
31.1	2	SN3500-M8-30	Zylinderschraube / Socket head screw	62810
34	1	SN5650-PMO-SA-T6-V01	Schieberanschlag / Slide stop	223216
34.1	2	SN3500-M16-45	Zylinderschraube / Socket head screw	62871
34.2	1	SN3500-M8-45	Zylinderschraube / Socket head screw	62813
35	1	SN5651-LOS-DS-50x20	Lock-Out-Distanzscheibe / Lock-Out-distance washer	227544
37	1	SN5650-PM-BV-T4-V01	Bajonettverschluss / Bayonet fitting	630767
37.1	1	SN3500-M8-20	Zylinderschraube / Socket head screw	62808
38	1	SN5650-PM-TYPS-V02	Typschild / Type plate	223226
39	4	SN5650-PM-PN-4-3	Popniete / Rivet	223192
60	1	Z7685	Endschalter / Limit switch	162771
60.1	1	SN3550-M2.5-8-SN1	Senkkopfschraube mit Schlitz / Countersunk head screw	10211362
60.2	1	SN2979-5-M4	Schlauchschelle einzeln / hose clamp single	600756
60.3	1	SN2980-M4-12	Schraube selbstschneidend / screw self-cutting	600757
61	1	SN5650-PM-SB-T2-V01	Sensorblech / sensor plate	10211284
61.1	2	SN3550-M4-8	Senkkopfschraube / Countersunk head screw	62638
106	2	SN5650-PMO-EZT-T6-V01	Einsatz Zwangsrückzug / Application active return driver	223077
106.1	4	SN3500-M8-35	Zylinderschraube / Socket head screw	62811
108	3	SN5650-PM-PNR-4-3	Popniete rot / Rivet red	223266
117	2	SN5650-PM-SP-BSS-V01	Sicherungsplatte BSS / Safety plate	223306
117.1	2	SN3550-M6-16	Senkkopfschraube / Countersunk head screw	62642
120	2	SN1817-24-25	Druckstück / Thrust piece	64792
128	1	SN2820-750-63-PM	Gasdruckfeder für PM / Gas spring for PM	10086502

STRACK®

NORMALIEN

STRACK NORMA GmbH & Co. KG

Königsberger Str. 11
D-58511 Lüdenscheid
Postfach 16 29
D-58466 Lüdenscheid

Tel +49 2351 8701-0

Fax +49 2351 8701-100

Mail info@strack.de

Web www.strack.de



Management
System
ISO 9001:2015

www.tuv.com
ID 0910092006