

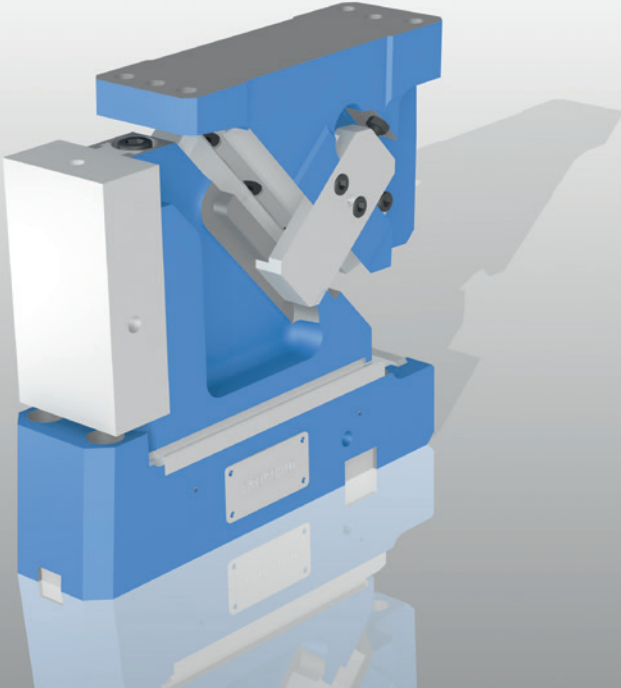

Unten stehende Schieber	Die mount cam unit	Coulisseau monté en bas
<b>SN5650-PMU-0065</b>		
 		
Mat.: EN-GJS-600-3 (GGG 60)		

Arbeitsfläche:	Working Area:	Plan de travail:
65 mm x 120 mm	65 mm x 120 mm	65 mm x 120 mm
Schieberbreite max.:	Cam Unit Width max.:	Largeur du coulisseau max.:
65 mm	65 mm	65 mm
Einbauhöhe:	Installation height:	Hauteur de montage:
225 mm	225 mm	225 mm
Presskraft:	Press force:	Force de pressage:
100 kN	100 kN	100 kN

<b>PMU-0065</b>	<b>Angaben beruhen auf einer Einschraubtiefe von: / Information is based on screw-in depth of: / Les informations sont basées sur la profondeur de vissage de:</b>	
<b>Befestigung / Fixing / Fixation</b>	<b>2,5 x d</b> bei niedrigen Gussqualitäten for low casting qualities pour qualités de fonte faibles	<b>1,5 x d</b> bei Gussqualitäten GG25 oder höher for casting qualities GG25 or higher pour qualités de fonte GG25 ou plus hautes
<b>Schrauben / Screw / Vis</b> Treiber / Driver / Propulseur Schieberführung / Slide retainer / Réception du coulisseau	<b>Anzahl / Quantity / Nombre - d - l</b> 4x - M10 - 35 4x - M10 - 40	<b>Anzahl / Quantity / Nombre - d - l</b> 4x - M10 - 25 4x - M10 - 30
<b>Stifte / Dowel pins / Goupilles</b> Treiber / Driver / Propulseur Schieberführung / Slide retainer / Réception du coulisseau	<b>Anzahl / Quantity / Nombre - d - l</b> 2x - Ø10 - 30	<b>Anzahl / Quantity / Nombre - d - l</b> 2x - Ø10 - 30
<b>Passfedern / Fitting keys / Clavettes</b> Schieberführung / Slide retainer / Réception du coulisseau längs / longitudinal / longitudinale quer / across / en travers	<b>Anzahl / Quantity / Nombre - l x b x h</b> 2x - 30 x 25 x 25 1x - 60 x 25 x 25	<b>Anzahl / Quantity / Nombre - l x b x h</b> 2x - 30 x 25 x 25 1x - 60 x 25 x 25

Unten stehender Normschieber  
SN5650-PMU-0065

Die mount cam unit  
SN5650-PMU-0065

Coulisseau monté en bas  
SN5650-PMU-0065

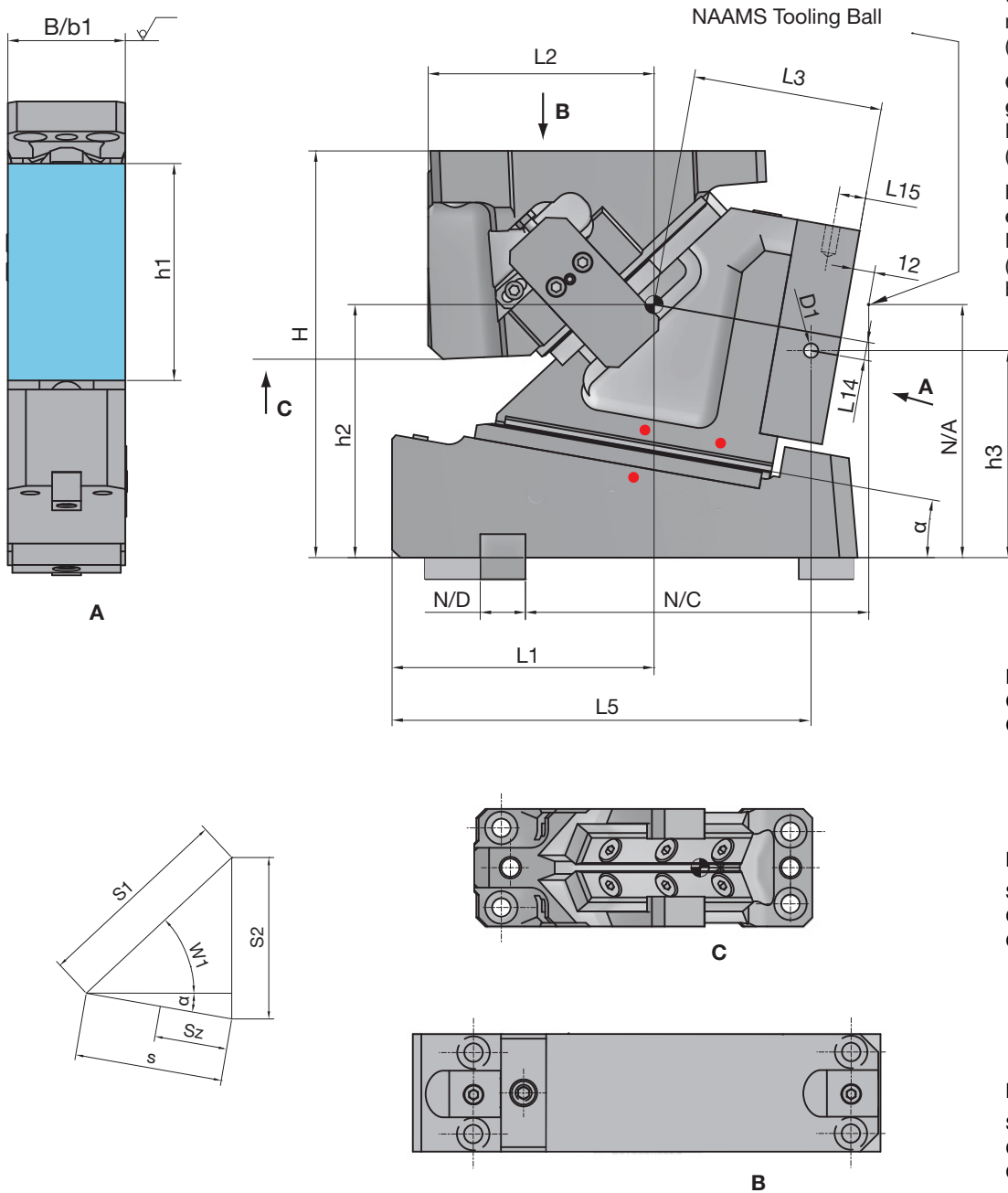

Gusstoleranzgrad CT  
nach DIN ISO 8062  
(blau = Rohgussfläche)

Casting tolerance  
grade CT according to  
DIN ISO 8062  
(blue = raw casting area)

Degré de tolérance  
de coulée CT selon  
DIN ISO 8062  
(bleu = zone de coulée  
brute)

Positionskontrolle:  
Control of position:  
Contrôle de la position:

**Pos. 1**  
Schieber zusammengefahren  
Cam is moved together  
Coulisseau est fermé

**Pos. 2**  
Schieber ausgefahren  
Cam is extended  
Coulisseau est étendu

N/\*= Maße NAAMS  
N/\*= Dimensions NAAMS  
N/\*= Dimensions NAAMS

(Z) = Maße nur für Zylinderstift Zentrierung  
(Z) = Dimensions only for dowel pin alignment  
(Z) = Dimensions seulement pour le centrage  
de la goupille cylindrique

Presskraft [kN]	Press force [kN]	Force de pres- sage [kN]	Rückzugs- kraft [kN]	Retraction force [kN]	Force à retour [kN]
Basis	Medium	Premium	Basis	Medium / Premium Standard	
> 107	> 184	> 184	1	21	-

### Unten stehender Normschieber

### Die mount cam unit

### Coulisseau monté en bas

#### SN5650-PMU-0065



SN5650-PMU-0065-α-B/M/P-N/Z

Mat.: EN-GJS-600-3 (GGG 60)



B = Basis  
M = Medium  
P = Premium

N = Nutenstein - Zentrierung  
Sliding block - Alignment  
Clavette - Centrage

Z = Zylinderstift - Zentrierung  
Dowel pin - Alignment  
Goupille cylindrique - Centrage

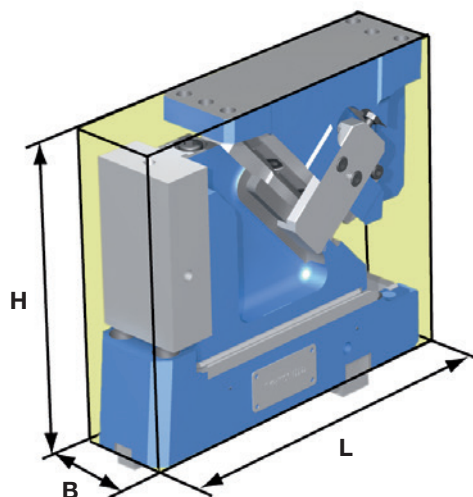

Einbauraum  
Installation space  
Espace de montage

α	0°	5°	10°	15°	20°	25°
L	248	245	259	267	279	286
B	65	65	65	65	65	65
H	225	225	225	225	225	225
W1	48°	43°	43°	38°	38°	33°
s	58	58	58	58	58	58
S1	86,7	79	78,1	71,1	69,2	62,7
S2	64,4	58,9	63,3	58,8	62,4	58,6
Sz	56	56	56	56	56	56
H	225	225	225	225	225	225
B	65	65	65	65	65	65
b1	65	65	65	65	65	65
h1	120	120	120	120	120	120
h2	140	140	140	140	145	145
h3	130,00	122,19	114,52	107,05	104,82	97,90
L1	125	135	145	150	160	165
L2	125	120	125	120	135	130
L3	105	105	105	105	105	105
L5	215,00	223,79	231,90	234,35	241,15	242,34
N/A	160	150	140	135	130	130
N/C	170	180	190	200	210	210
N/D	25	25	25	25	25	25

Bauteile

Components

Éléments

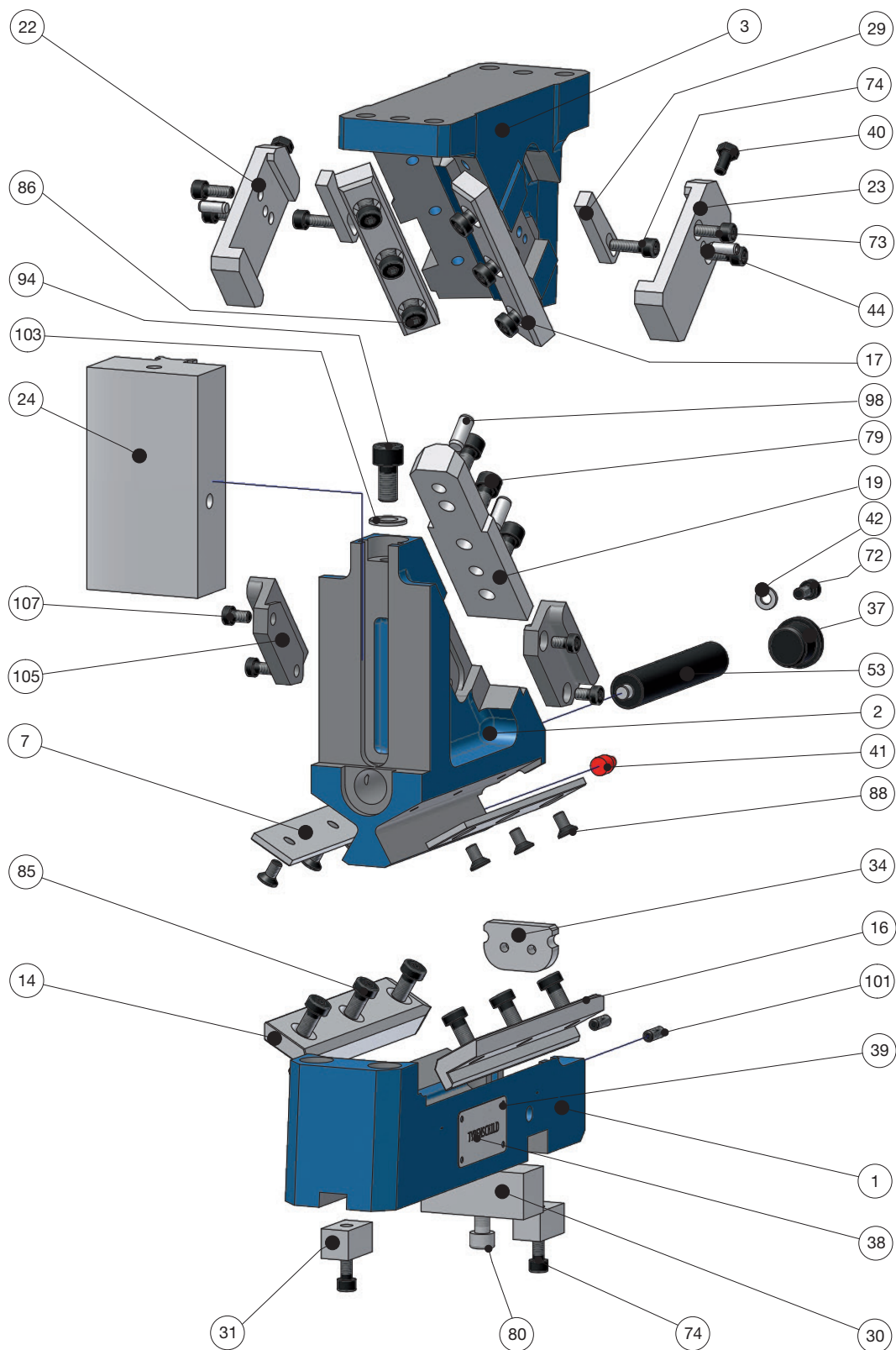

Angaben zum **Lock-Out-System** ab Seite 269 / Further details about **Lock-Out-System** from page 269 /  
Détails supplémentaires dont **Système de verrouillage** à page 269

### Stückliste

### List of items

### Liste des pièces

Nr. No. no.	Artikel Article L'article	Benennung Description Dénomination
1	Schieberaufnahme Fertigteil / Slide retainer, machined part / Réception du coulisseau, élément fabriqué	SN5650-PMU-SAF ...
2	Schieberkörper Fertigteil / Slidebody, machined part / Corps du coulisseau, élément fabriqué	SN5650-PMU-SKF ...
3	Treiber Fertigteil / Driver unit, machined part / Propulseur, élément fabriqué	SN5650-PMU-TF ...
7	Bepankung Schieberbett / Planking slidebed / Plaques de protection plateau du coulisseau	SN5650-PM-BS ...
14	Gleitplatte Schieberaufnahme links / Guideplate slide retainer left / Plaque de frottement réception du coulisseau à gauche	SN5650-PM-GSA1 ...
16	Gleitplatte Schieberaufnahme rechts / Guideplate slide retainer right / Plaque de frottement réception du coulisseau à droite	SN5650-PM-GSA2 ...
17	Gleitplatte Schieber-Treiber / Guideplate slider-driver / Plaque de frottement coulisseau-propulseur	SN5650-PM-GST ...
19	Gleitstück Treiber links / Guidepiece driver left / Pièce coulissante propulseur à gauche	SN5650-PMU-GTL ...
22	Zwangsrückzug links / Active return left / Retour actif à gauche	SN5650-PMU-ZWL ...
23	Zwangsrückzug rechts / Active return right / Retour actif à droite	SN5650-PMU-ZWR ...
24	Aufbauplatte / Mounting plate / Plaque de montage	SN5650-PMU-AP ...
29	Keil Zwangsrückzug / Key active return / Clavette retour actif	SN5650-PM-KEZ ...
30	Passfeder 1 / Fitting key 1 / Clavette 1	SN5650-PM-PS1 ...
31	Passfeder 2 / Fitting key 2 / Clavette 2	SN5650-PM-PS2 ...
34	Schieberanschlag / Slide stop / Butée du coulisseau	SN5650-PMU-SA ...
37	Verschlussstopfen / Plug / Bouchon d'étanchéité	SN5650-PM-VS ...
38	Typschild / Type plate / Anneau du type	SN5650-PMU-TYPS ...
39	Popniete / Rivet / Rivet	SN5650-PMU-PN ...
40	Sechskantschraube / Hexagonal screw / Vis hexagonale	SN5650-PMU-SKS ...
41	Dämpfungsstück / Absorbality piece / Pièce d'amortissement	SN1817 ...
42	Scheibe / Disc / Disque	SN5650-PMO-SB
44	Zylinderstift / Dowel pin / Goupille cylindrique	SN1975 ...
53	Gasdruckfeder / Gas spring / Ressort à gaz	SN2800 ...
72-94	Zylinderkopfschraube / Cylinder head cap screws / Vis 6 pans creux	SN3500 ... / SN3540 ...
98	Zylinderstift / Dowel pin / Goupille cylindrique	SN1975 ...
101	Stiftschraube / Stud screw / Boulon fileté	SN3600 ...
103	Scheibe / Disc / Disque	SN5650-PMU-SB ...
105	Einsatz Zwangsrückzug Schieber / Application active return slider / Garniture de retour actif coulisseau	SN5650-PMO-EZS ...
107	Zylinderkopfschraube / Cylinder head cap screws / Vis 6 pans creux	SN3540 ...

### Kraftverteilung

### Force Distribution

### Distribution de force

#### Basis

$\alpha$	[kN]					[mm]		FA [kN]
	FS	FP	Fh1	FW	Fh2	h1	h2	
00°	107	97	108	97	-1	110	40	1
05°	111	102	103	92	10	108	53	1
10°	115	106	99	86	21	105	65	1
15°	119	110	94	79	37	98	80	1
20°	122	114	89	72	53	90	95	1
25°	122	122	79	70	79	85	110	1

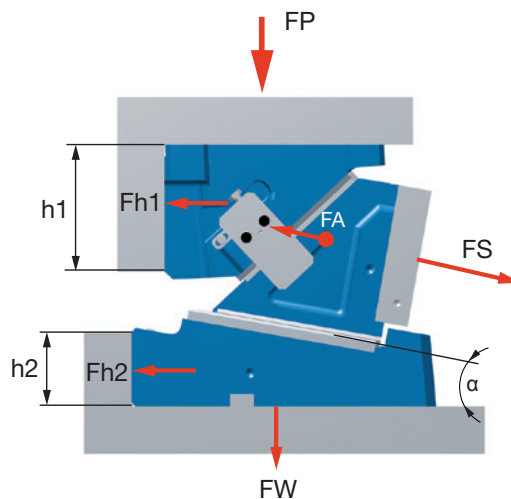

#### Medium / Premium

$\alpha$	[kN]					[mm]		FA [kN]
	FS	FP	Fh1	FW	Fh2	h1	h2	
00°	184	166	185	166	-1	110	40	21
05°	191	174	177	157	18	108	53	21
10°	198	182	170	148	36	105	65	20
15°	204	189	161	136	64	98	80	20
20°	210	196	153	124	91	90	95	19
25°	210	209	135	120	136	85	110	17

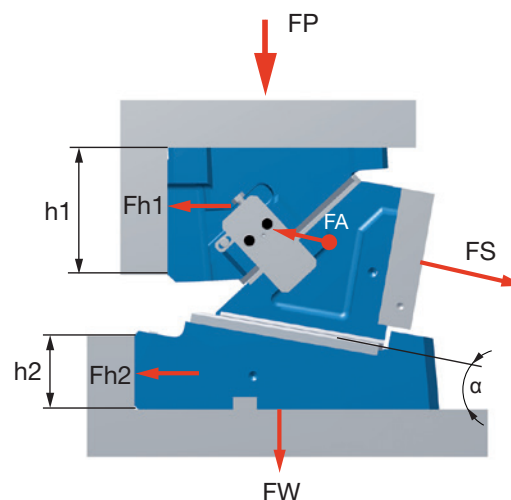

<b><math>\alpha</math></b> Schieberwinkel Cam Angle Angle du Coulisseau	<b>FP</b> P-Press P-Press P-Press	<b>FW</b> W-Werkzeug W-Tool W-Outillage	<b>FS</b> S-Schieberkraft S-Cam Force S-Force du Coulisseau	<b>FA</b> A-Abstreifkraft A-Retractility A-Force démouler	<b>Fh1</b> h1-Abschulterung oben h1-Shouldering above h1-Épauler en haut	<b>Fh2</b> h2-Abschulterung unten h2-Shouldering below h2-Épauler en bas
--	--	--	--	--	---	---

### Schieberkräfte

### Cam Force

### Force du coulisseau

Abschulterung  
Shouldering  
Épauler

Passfeder  
Fitting Key  
Clavette

Abschulterung  
Shouldering  
Épauler

Passfeder  
Fitting Key  
Clavette

#### SN5650-PMU-0065-0°-B-N/Z

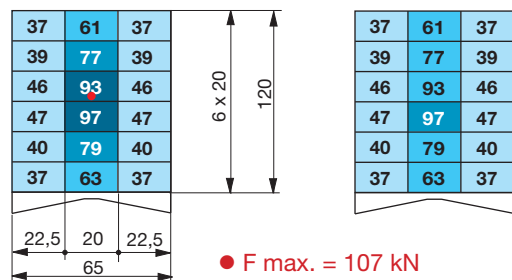

#### SN5650-PMU-0065-10°-B-N/Z

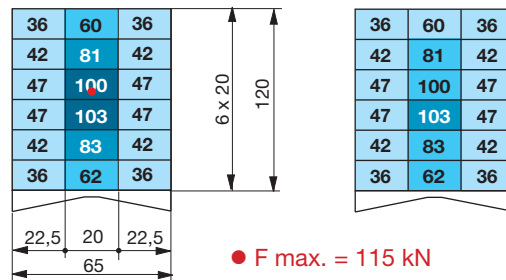

#### SN5650-PMU-0065-20°-B-N/Z

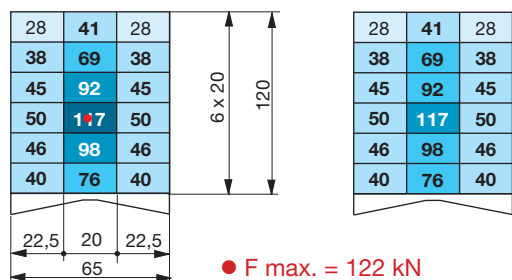

### Schieberkräfte

### Cam Force

### Force du coulisseau

Abschulterung  
Shouldering  
Épauler

Passfeder  
Fitting Key  
Clavette

Abschulterung  
Shouldering  
Épauler

Passfeder  
Fitting Key  
Clavette

#### SN5650-PMU-0065-0°-M/P-N/Z

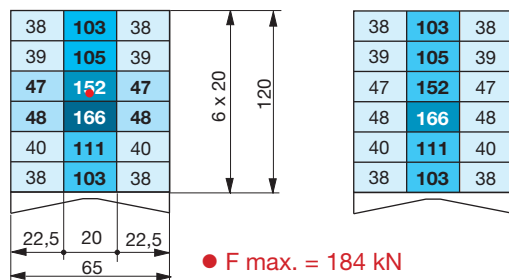

#### SN5650-PMU-0065-10°-M/P-N/Z

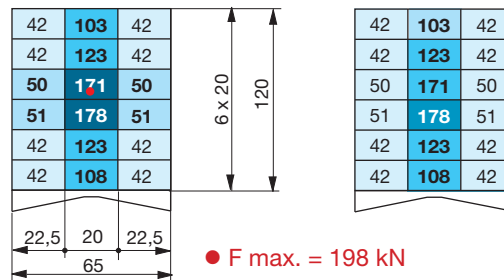

#### SN5650-PMU-0065-20°-M/P-N/Z

