

Schneidbuchsen

Cutting bushes

Matrices pour trous

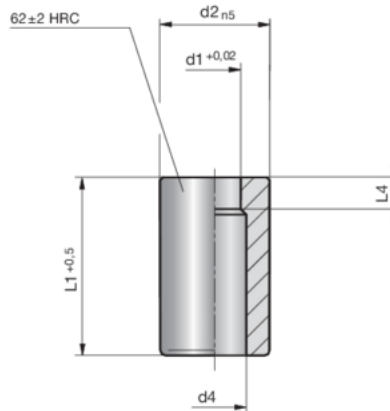

4

SN1872A-HSS-

Mat.: HSS (1.3343)
ISO 8977 A

SN1872A-HSS-
d1-L1-d2



X* – Stufung in mm
– graduation in mm
– progression en mm

d1	L1	d2	d4 (max)	L4 (min)	X* (d1)
1,0 - 2,4	20	5	2,8	2	0,1
1,6 - 3,0	20 / 25	6	3,5	3	0,1
2,0 - 3,5	20 / 25	8	4,0	4	0,1
2,5 - 5,0	20 / 25 / 32	10	5,8	4	0,1
4,0 - 7,0	20 / 25 / 32	13	8,0	5	0,1
6,0 - 9,0	20 / 25 / 32	16	9,5	5	0,1
8,0 - 11,0	20 / 25 / 32	20	12,0	8	0,1
10,7 - 16,0	20 / 25 / 32	25	17,3	8	0,1
15,0 - 20,0	20 / 25 / 32	32	20,7	8	0,5
19,0 - 27,0	25 / 32	40	27,7	8	0,5
26,0 - 36,0	32	50	37,0	8	0,5