

Minischieber für Folgeverbund



SN5630-

Mat.: ST

SN5630-B1



s = Schieberhub
Cam stroke
Course de coulisseau

S2 = Werkzeughub
Tool stroke
Course de l'outil

FS = Schieberkraft
Cam force
Force de coulissement

Mini-Slide unit for progressive die

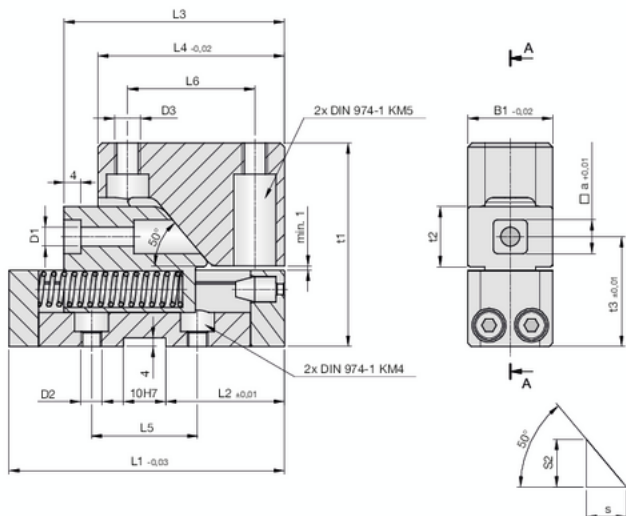

B1	t1	L1	L2	L3	L4	L5	L6	t2	t3	a	H	D1	D2	D3	s	S2	FS [N]
20	48	65	28	52	44	32	30	14,2	25,9	8	2	4,5	M5	M6	9,5	11,3	1600
30	62	84	37	69,5	59	45	39	19,9	33,04	12	4	4,5	M5	M6	13	17	7900

Einbaubeispiel:
Einbau in Werkzeugoberteil
mit Abschlüpfung, im Werk-
zeugunterteil mit Nutstein.

Installation example :
Installation in the upper part
of the tool with shouldering, in the
lower part of the tool with slot nut.

Einbaubeispiel:
Einbau in Werkzeugoberteil
mit Abschlüpfung, im Werk-
zeugunterteil in Tasche.

Installation example :
Installation in the upper part of
the tool with shouldering, in the
lower part of the tool in pocket.

Exemple d'installation:

Installation dans la partie supérieure de l'outil avec épaulement,
dans la partie inférieure de l'outil avec écrou coulissant.

