

Gasdruckfedern kleine Abmessungen

Gas springs small dimensions

Ressorts à gaz dimensions petites

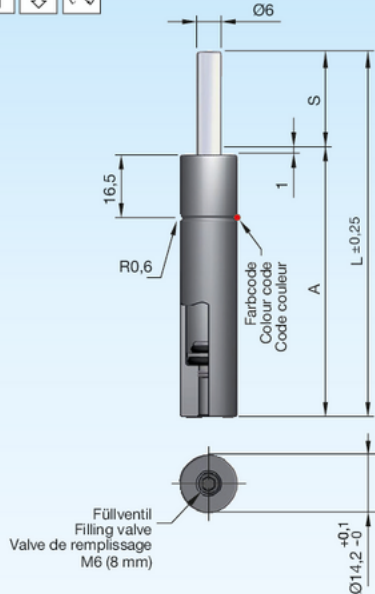

Einbauvarianten / Installation variants / Variantes de montage



Druckmedium	Pressure medium	Médium de pression	Stickstoff (N ₂)
Max. Fülldruck	Max. filling pressure	Pression de rempl. max.	175 bar
Min. Fülldruck	Min. filling pressure	Pression de rempl. min.	50 bar
Max. Betriebs-temperatur	Max. working temperature	Température de service max.	80 °C
Temperaturabhängige Druckerhöhung	Pressure increase due to temperature	Accroissement de pression sous l'influence de la temp.	0,33 %/1 °C
Instandhaltungsset	Maintenance kit	Jeu de maintenance	SN2990-C14
Max. Kolben-geschwindigkeit	Max. piston speed	Vitesse max. du piston	0,5 m/s

3

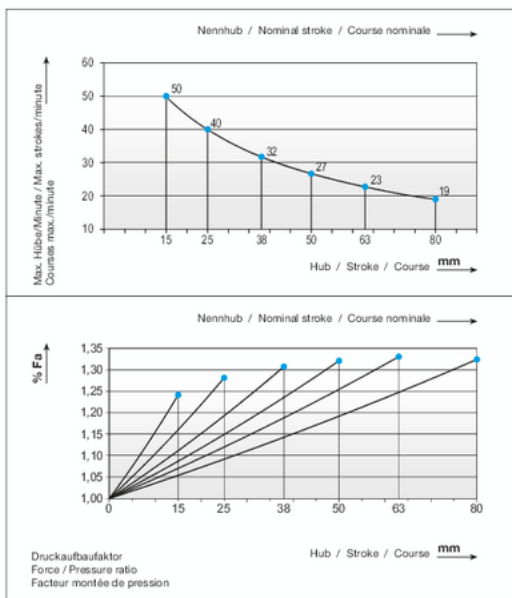

SN2800-50-		S	Type	A	L	V [l]	Fa [cm ²]	kg
 SN2800-50-S-Type		15	1	57	72	0,002	0,28	0,06
		25	2	67	92	0,003	0,28	0,08
		38	3	80	118	0,005	0,28	0,09
		50	4	92	142	0,006	0,28	0,10
		63		106	169	0,007	0,28	0,12
		80		125	205	0,009	0,28	0,15
Type	Farbcode Colour code Code couleur	daN	daN	bar				
1	Grün / Green / Vert	20 (-5)	25	70				
2	Blau / Blue / Bleu	30 (-5)	40	110				
3	Rot / Red / Rouge	40 (-5)	50	142				
4	Gelb / Yellow / Jaune	50 (-5)	65	175				
Andere Kräfte / Other forces / Autres forces		14-50	≈20-65	50-175				

SN2996* = Seite / Page 2.3.254