

NORMALIEN report

Release 28 • October, 2010

The information service for the tool- and mould making of **STRACK®**
NORMALIEN

Perfect cable coaching with GGK: The cable managers

Electrical installation systems: Function meets design



■ Skilful cable management: GGK produces high quality cable guiding channels.

Management is a question of creativity – cable management even more. You have to know the right solution. On the local market GGK is one of the leading suppliers of creative solutions for the laying of cables on plaster. The strength of the trademark: the production of cable management systems not only out of plastics, but also out of metal. The attribute of the trademark: making the visiblens invisibly. Even “Perfect cable coaching”.

GGK offers professional solutions for the systematic disposing of cables. In the comfortable living room as well as in the working environment, in the production or in the office. GGK products take care for the arrangement and security in the world of cable laying, because of the fact that cable chaos and stumbling blocks belong once and for all to the past. For versatile utilization demands of the electrician, the extensive program offers all necessary things in the most different designs and in an optically pleasant form. The program offers all, beginning with the visually noble room columns out of anodized aluminium, continuing with the classic rail channels in the office up to the cable channels with function preservation out of galvanized sheet steel. You can buy them with the well-organized electrical specialist on-site.

“We create our developments by ourselves and produce with a high production depth.” Ulrich Labonte, chief of the development department stresses here-with the fact why GGK occupies a niche very successfully. The cable managers out of Greifenstein in Hesse are supported in doing so by the standard part managers of Lüdenscheid in the Sauerland. The products of STRACK NORMA are used in the plastics production as well as in the production of channels out of metal. “The parts of STRACK NORMA are always available,” commends Ulrich Labonte, who realizes completely new applications with the columns guides and bushes, for example in the punching sector.

...further information on page two

Editorial



2010 is the year of the K-fair. After 3 years the international leading fair for plastics and caoutchouc takes again place at Düsseldorf. Of course STRACK NORMA will be on-site as contact person for the professional visitors in hall 1 at booth F09. We will present numerous new product developments and product advancements at which you can of course have a look and which you can test on-site.

There could not be a better date to present our absolute top innovation to the international technical experts. In Düsseldorf we present for the first time our new centering unit W44 in public. A unit which makes the centering of cavity plates imaginable simple. Concerning the development we centered our efforts - corresponding to our philosophy – on the practicability as well as on economic aspects.

And if you are not able to have a look at our new developments in Düsseldorf, simply call us. Our application engineers will be pleased to present the STRACK-products personally.

Have much fun while reading!

D. Friedrich

Dag Friedrich
Business Manager

...continuation page 1



■ Precision: In the own toolmaking of GGK the standard parts of STRACK NORMA are mounted.

Our technology paired with our know-how set benchmarks in the running of cables," explains Ulrich Labonte, who has puzzled out new product system for GGK for five years. Moreover the classic bottom-hole punching dies for cable channels are equipped with products of Lüdenschaid.

GGK supplies the electrical wholesale "just in time" and thus in the production all things have to function without problems. Hence Ulrich Labonte particularly commends that STRACK NORMA supports the demand of the managers with its high delivery capacity. The visitor with GGK sees why this is so important when he enters the production site. Here at nearly countless extruders, channels in the most different lengths and widths are produced- in a manner of speaking kilometers of cable management.

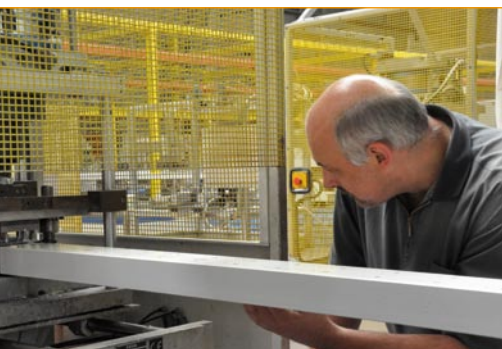

■ Quality: Ulrich Labonte examines daily the quality of the rail channels in the production.

Not only must the precision be secured permanently, but also the surface quality. The perfect visual appearance is important. We finally eliminate the cable tangle in the respective room situation with a decorative demand." The daily tour through the production line and the scrutiny on the surfaces of the extruded plastic channels is an absolute necessity for the skilled precision mechanic technician.

More flexibility concerning ejectors

New ejectors Z4262 are high-wear resistant

With the ejector Z4262 and Z4264 STRACK NORMA has included new flexible ejectors in its product range. These ejectors are the ideal choice for the demoulding of undercuts. Compared to the standard types they need less space in the mould design.

The products characterize by the utilization of special steel and a high-quality coating with a very high wear resistance. Materials like these are used in the aerospace technology and are subjected to highest quality requirements. The ejectors are available in a one-armed and a two-armed version and in different widths and total lengths. The program is perfected by reasonable accessories like ejector extensions and wear inserts.



■ For the two-armed version Z4264 reasonable accessories exist.

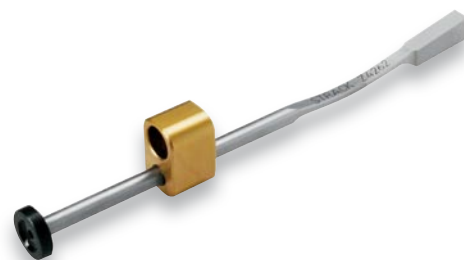

■ The one-armed ejector Z4262 is available in different widths and lengths.

New limit switches: switching at the end

Z7615-M can directly be inserted in the slide cavities

The insertion of the internal limit switches in the slide cavities is a great advantage of the new product, which has the article number Z7615-M. The new limit switch is ideally suited for inquiring the slide position in the tool directly at the slide to avoid false positions and consequently the break of the tool reliably. Combined with the test light Z7601 and the corresponding adapter Z7601-1, it can exactly

be adjusted. The micro limit switch, which is mounted in an aluminium case, can be used in temperature areas of up to 70 °C and is splash-proofed according to IP40. The utilization of several limit switches at a simultaneous switching is possible by using the alternative adapter housings Z7616 / Z7617. Not used adapters can comfortably be bridged by dummy plugs.



■ Inquiry directly at the slide. The new limit switch Z7615-M.

STRACK-team on fair tour in autumn

New products are presented on three fairs

The sales team as well as the application engineers of STRACK NORMA is facing a "hot" autumn. The standard part specialist is still present on 3 fairs till the end of this year and introduces its' product innovations from both product ranges for injection moulding dies and die casting moulds as well as for punching and forming tools.



The EuroBLECH takes place in Hannover from 26th to 30th October. The 21st remake of this international technology fair for sheet metal forming has the motto "Ideas and Know-How for the future". In hall 13 at booth D08 definitely the PowerMax® will be in the centre of interest. "The cam series turned out to be a bestseller. Among other things the PowerMax® has

already been used successfully by two automobile manufacturers", explains Ludger Müller, the technical manager.



After three years the K-fair opens its gates again. Düsseldorf is the Mecca of the plastics branch from the 27th October till 3rd November. The leading fair is the biggest trade fair for plastics and cautchouc worldwide. Traditionally STRACK NORMA exhibits on the fair. This year the booth F09 is in hall 1.



The EuroMold, world fair for tool- and mould making takes place as usual at the beginning of December in Francfort, this year from the 1st till the 4th December. STRACK NORMA is a permanent guest at the trade fair in the Main metropole. Like in the years before, you will find the booth in hall 9.0, stand A101.

Customers now have the possibility to have a look at the booking schedule prior to the respective fair. Thereby you can plan your fair visit in such a manner that you will meet the desired contact person at the booth of STRACK NORMA. The documents are ready for download under www.strack.de.



First of all: being on site: application engineer Jürgen Krugmann presents new products for the forming- and hot-runner technology of STRACK NORMA.

The construction tip:

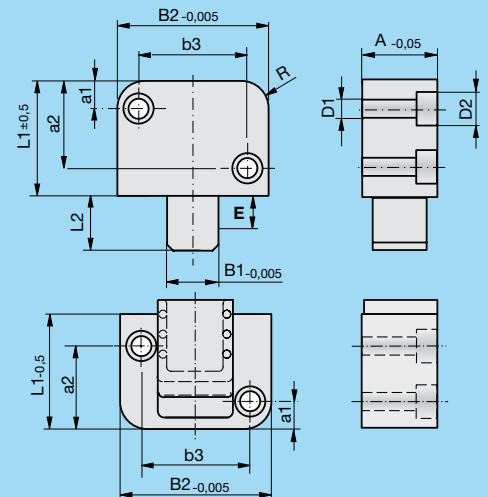
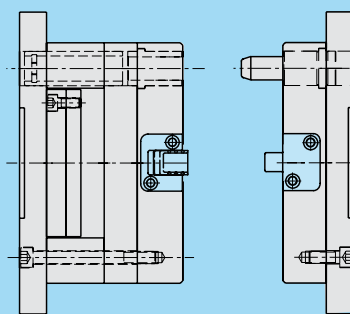
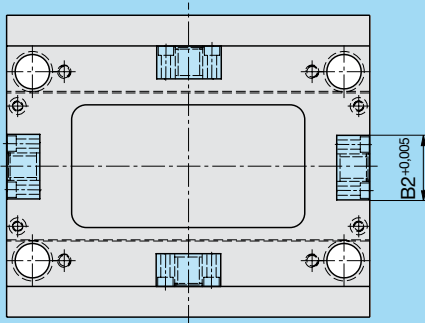

The centering of cavity plates can be very time-consuming in the practical experience. For the perfect centering of both cavity plates with the centering unit W44 an absolute and patented innovation of the company STRACK NORMA is available for the experts.

The new centering unit W44 works absolutely play-free after the mounting. This mounting condition is reached by

a pre-stressing of at least three thousandth millimeters. During the development the principle of the ball cage served as model. At the centering unit the bearing is realized by needle rollers.

A great advantage of this unit is without doubt the fact that it works nearly wear-free. In time-consuming tests even after 3 million strokes no traces of wear could be proved. Besides

the longevity, the simple mounting of the centering unit in the tool is a further characteristic.

As product supplement to the already existing rectangle guidances Z46/48 and the centering unit Z50, the centering unit W44 can be received in the installation sizes 32 mm x 63 mm and 40 x 100 mm.

Imprint

The „Normalienreport“ is an information service of STRACK NORMA GmbH & Co.KG
Königsberger Straße 11
D-58511 Lüdenscheid
Tel.: +49 (0) 23 51 - 87 01 -0
Fax: +49 (0) 23 51 - 87 01 -100
www.strack.de

Conception, text and layout:

[vogomedia]
Marketing & Kommunikation
Friedrich-Ebert-Str. 294-296
D-58566 Kierspe
www.vogomedia.de

Successful: Remake of the TOOLservice 2011

Concept should be maintained – major focus on own developments

“We were overwhelmed by the positive feedback”, concluded the business manager Dag Friedrich. In fact the organization team of the TOOLservice reckoned with much less guests at the premiere. Within two days about 180 guests informed themselves about “the world of the standard parts”. With good cause there will be a remake next year. This will again take place in the company of STRACK NORMA on the 4th and 5th May 2011.

The Wednesday will be in the centre of the mould technology for injection moulding dies and die casting tools. One day later the experts for punching- and forming tools will present new procedures and product developments. “We will follow the multiple expressed wish of our premiere guests to present even more products and procedures of

STRACK NORMA by ourselves”, says Dag Friedrich. Of course each participant of this TOOLservice, which is planned as further training activity, has the possi-

bility to get an insight in the production of standard parts. On each day after lunch a round tour through the premises is planned.



■ TOOLservice – the second: Next year STRACK NORMA invites the experts again to come to Lüdenscheid.

New guide bushes for a clean production

Low maintenance effort – temperature resistant up to 200°C

In the individual classes of cleanrooms products out of plastic are produced in a dust-free and sterile way. As is generally known, under these production conditions, the human being is the biggest source for the dumping of undesired dust particles and germs.

The standard part producer STRACK NORMA has particularly developed special standard parts for these sensible production conditions for the medical technology, electrical engineering or for the food production industry, which are presented for the first time on the K-fair in Düsseldorf. These feature themselves by a very low maintenance effort, which reduces the danger of particle- and germ emission considerably.

New in the product range of STRACK NORMA are actually guide bushes – a further development of the proven guide bushes of the standard range. These bushes, which are produced out of high-quality bronze and a special plastic material, dispose of special characteristics due to this material combination. Moreover they are temperature-resistant up to 200 °C. The guide bushes can be received in a manifold type selection with different lengths and diameters.

With the company STRACK NORMA a team of application engineers is at your



■ Many standard parts of STRACK NORMA are suited for the production in cleanrooms.

disposal concerning the construction and development of tools for production in cleanrooms. The application engineers support the constructing engineers concerning the selection of the adequate materials and standard parts.

STRACK[®] NORMALIEN

STRACK NORMA
congratulates the employees
who have belonged to the
STRACK family for many years.

10 years
Dirk Grote 01.10.

25 years
Kay-Uwe Köhler 02.12.
Rolf Dettmar 09.12

Congratulations!