

Gasdruckfedern TITANserie

Gas springs TITANseries

Ressorts à gaz TITANsérie

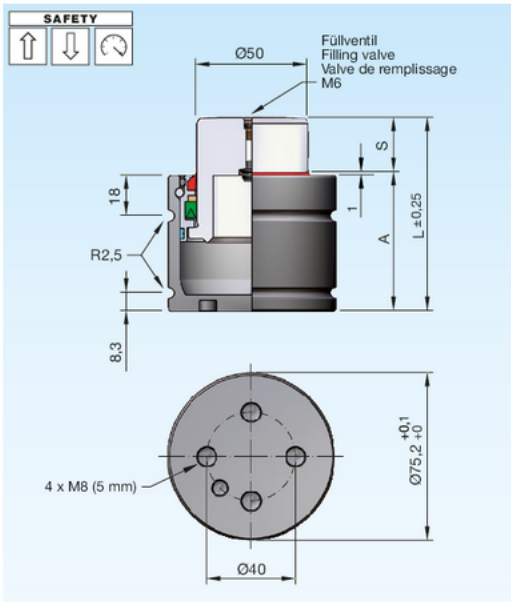

Einbauvarianten / Installation variants / Variantes de montage

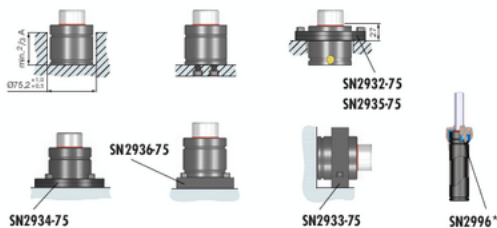

Druckmedium	Pressure medium	Médium de pression	Stickstoff (N ₂)
Max. Fülldruck	Max. filling pressure	Pression de rempl. max.	150 bar
Min. Fülldruck	Min. filling pressure	Pression de rempl. min.	50 bar
Max. Betriebs-temperatur	Max. working temperature	Température de service max.	80 °C
Temperaturabhängige Druckerhöhung	Pressure increase due to temperature	Accroissement de pression sous l'influence de la temp.	0,33 %/1 °C
Instandhaltungssatz	Maintenance kit	Jeu de maintenance	SN2990-T75
Max. Kolbengeschwindigkeit	Max. piston speed	Vitesse max. du piston	0,8 m/s

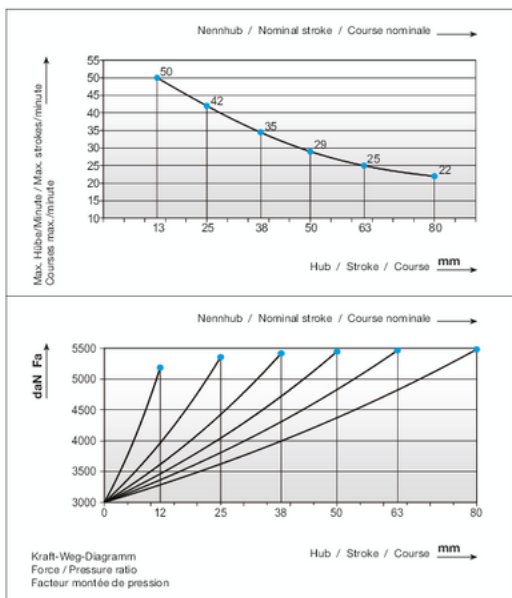

SN2807-3000-



SN2807-3000-S



S = Hub / Stroke / Course

bar = Fülldruck / Filling pressure / Pression de remplissage

* i SN2996 = Seite / Page 2.3.254

S	daN	daN	bar	A	L	V [l]	Fa [cm ²]	kg
12	3000	5160	150	49	61	0,056	19,63	1,25
25	(±5%)	5330	150	62	87	0,112	19,63	1,39
38		5390	150	75	113	0,167	19,63	1,62
50		5420	150	87	137	0,219	19,63	1,72
63		5435	150	100	163	0,274	19,63	1,99
80		5455	150	117	197	0,347	19,63	2,18