

Elastomer-Abstreifer

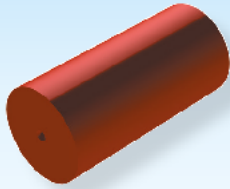

SN1816-

1 daN = 10 N
Mat.: PUR

SN1816-D2-L1



Polyurethane stripper

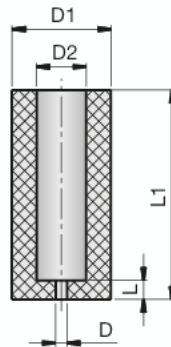

Dévêtisseur en polyuréthane

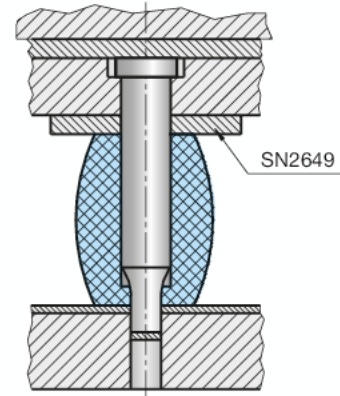

4

D2	L1	D1	D	L	Abstreiferkraft in [daN] bei Verformung von Stripper force in [daN] at deformation of Force du dévêtisseur [daN] à la déformation de		
					3 mm	6 mm	9 mm
4	45	17	1,6	5	60	115	-
6	55	19	1,6	5	65	120	180
8	55	21	3	5	70	130	210
10	55	23	3	5	90	160	240
13	55	26	3	5	110	190	300
16	55	30	3	5	140	230	370
20	55	38	3	5	210	360	550
25	55	50	3	5	370	650	1020

Druckstücke



SN1817-

1 daN = 10 N
Mat.: PUR

SN1817-D1-L1



Thrust piece

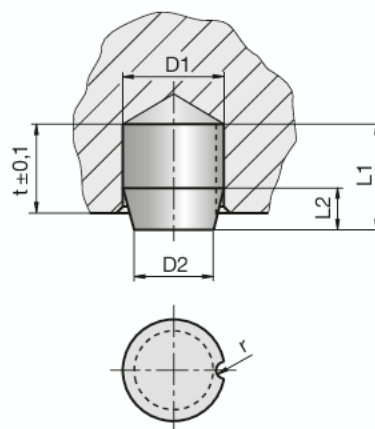

Pièce recevant la pression

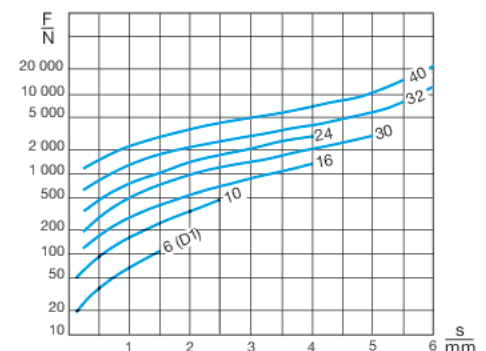

D1	L1	L2	D2	t	r	F [daN] max.	D1	L1	L2	D2	t	r	F [daN] max.
6	9,5	4,5	3,6	8		10	30	35	19	20	30	2,5	300
10	15,5	7,5	6	13	1	45	32	32	14	24	26	3	1200
16	25	12	9,5	21	1,5	150	39,5	40	16	30	34	3	2500
24	25	10	18	21	2	300							