

Gasdruckfedern TITANserie

Gas springs TITANseries

Ressorts à gaz TITANsérie

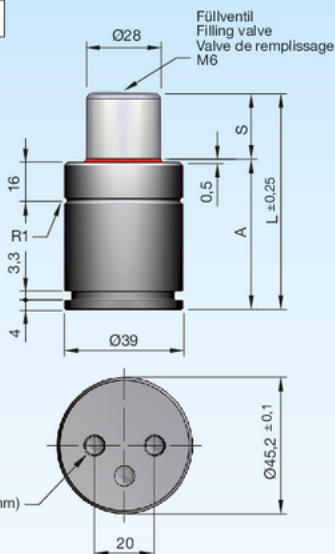

Einbauvarianten / Installation variants / Variantes de montage

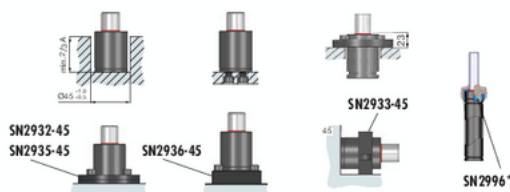

Druckmedium	Pressure medium	Médium de pression	Stickstoff (N ₂)
Max. Fülldruck	Max. filling pressure	Pression de rempl. max.	150 bar
Min. Fülldruck	Min. filling pressure	Pression de rempl. min.	35 bar
Max. Betriebs-temperatur	Max. working temperature	Température de service max.	80 °C
Temperaturabhängige Druckerhöhung	Pressure increase due to temperature	Accroissement de pression sous l'influence de la temp.	0,33 %/1 °C
Instandhaltungssatz	Maintenance kit	Jeu de maintenance	SN2990-T45
Max. Kolben-geschwindigkeit	Max. piston speed	Vitesse max. du piston	0,5 m/s

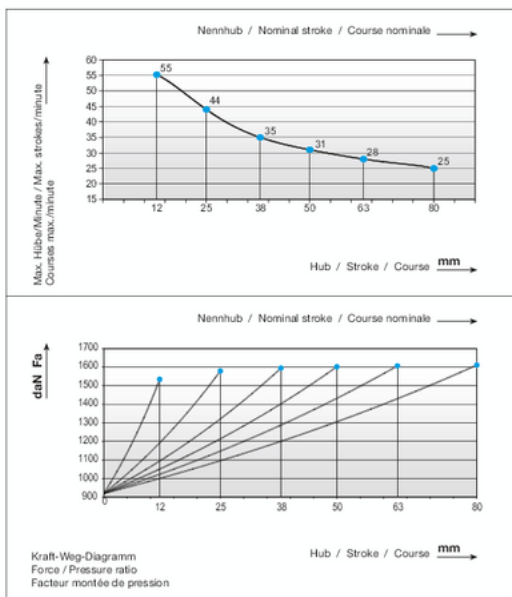

SN2807-920-

SN2807-920-S

S = Hub / Stroke / Course

bar = Fülldruck / Filling pressure / Pression de remplissage

* i SN2996 = Seite / Page 2.3.254

S	daN	daN	bar	A	L	V [l]	Fa [cm ²]	kg
12	920	1540	150	42	54	0,019	6,16	0,33
25	(±5%)	1585	150	55	80	0,037	6,16	0,43
38		1600	150	68	106	0,055	6,16	0,49
50		1610	150	80	130	0,072	6,16	0,58
63		1615	150	93	156	0,091	6,16	0,64
80		1615	150	110	190	0,115	6,16	0,84