

Gesteuerte Gasdruckfedern

Controlled gas springs

Ressorts à gaz contrôlés

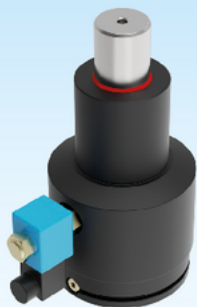

3

Druckmedium	Pressure medium	Médium de pression	Stickstoff (N ₂)
Max. Fülldruck	Max. filling pressure	Pression de rempl. max.	150 bar
Min. Fülldruck	Min. filling pressure	Pression de rempl. min.	50 bar
Max. Betriebs-temperatur	Max. working temperature	Température de service max.	60 °C
Temperaturabhängige Druckerhöhung	Pressure increase due to temperature	Accroissement de pression sous l'influence de la temp.	0,33 %/°C
Max. Kolben-geschwindigkeit	Max. piston speed	Vitesse max. du piston	0,5 m/s.
Max. empfohlene Hübe	Max. recommed strokes	Course recommandé max.	8 - 25[°] S/min.
* = Maximale Anzahl abhängig von Arbeitsparametern	* = Maximum rate will depend on working parameters	* = Nombre maximum dépendant des paramètres de travail	

Erforderliche Angaben des Kunden

Arbeitshub¹⁾: _____ mm
 Pressengeschwindigkeit: _____ m/min
 Maximale Pressenrate: _____ Hübe/min

¹⁾ Die 100 % Ausnutzung des Hubes **S** reduziert die max. möglichen Arbeitsparameter. 10 % Hubreserve sind in der Werkzeugkonstruktion einzukalkulieren.

Required information of the customer

Working stroke¹⁾: _____ mm
 Press speed: _____ m/min
 Maximum press rate: _____ Strokes/min

¹⁾ The 100 % utilization of the stroke **S** reduces the max. possible working parameters. 10 % stroke reserve is to be calculated in the tool construction.

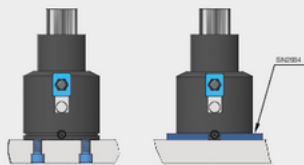

Type 1

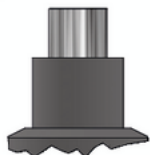

Type 2

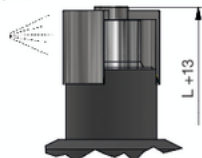

Type 3

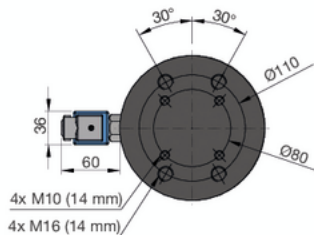
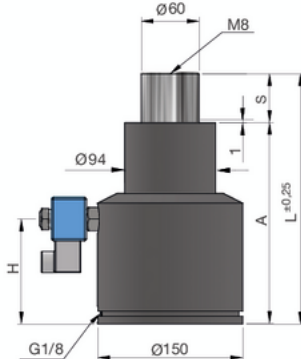
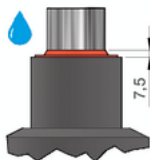

SN2884-4500



SN2884-4500-S-Type



S = Hub¹⁾ / Stroke¹⁾ / Course¹⁾

bar = Fülldruck / Filling pressure /
Pression de remplissage



S	Type	A	L	H	daN	daN	bar	Fa [cm ²]
50	1/2/3	208	258	88,5		5810		28,27
75	1/2/3	245	320	100,5	4500 ±5% (20°C)	6380	150 (20°C)	28,27
100	1/2/3	282	382	112,5		6450		28,27
125	1/2/3	319	444	124,5		6650		28,27