

**SN5650-PMU-0065 – SN5650-PMU-0260**  
**CAM UNITS**  
**OPERATING INSTRUCTIONS**

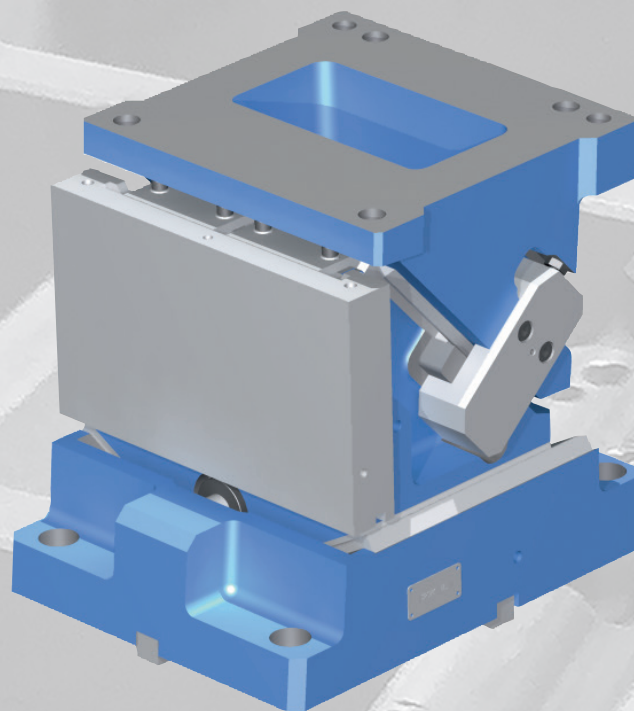

**PowerMax<sup>®</sup>**



**STRACK<sup>®</sup>**

**NORMALIEN**

| Content:  | Seite: |
|---|--------|
| Preamble  | 3      |
| 1. Safety instructions. Please absolutely consider!                         | 4      |
| 2. After receipt of delivery  | 5      |
| 3. Characteristics  | 6      |
| 3.1 Description of the construction types                                   | 7      |
| 4. Scope of delivery  | 7      |
| 5. Design of the PowerMax side cam  | 8      |
| 6. Preparation of tool and press  | 9      |
| 7. Shouldering  | 9      |
| 8. Production   | 10     |
| 8.1 Handling with safety ring bolt (SN1594)                                 | 11     |
| 8.2 Marking of the cams   | 12     |
| 9. Dismounting of the mounting plate at cam widths 0065-0260 (only Premium) | 13     |
| 9.1 Mounting of the mounting plate at cam units 0065-0260 (only Premium)    | 14     |
| 10. The Lock-Out-Systems  | 15     |
| 10.1 Lock-Out-System 2651-LOS   | 16     |
| 10.1.1 Mounting of the Lock-Out-System 2651-LOS                             | 17     |
| 10.2 Lock-Out-System 2654-LOS   | 19     |
| 10.2.1 Information of the Lock-Out-System 2654-LOS                          | 21     |
| 11. Dismounting / Mounting of the gas springs                               | 22     |
| 12. Modification of the system pressure of the gas springs                  | 23     |
| 12.1 Discharging of the pressure at a gas spring                            | 23     |
| 12.2 Increase of the pressure / charging of a gas spring                    | 24     |
| 13. Standstill and storing  | 26     |
| 14. Maintenance   | 26     |
| 14.1 Adjustment of the active return  | 27     |
| 14.2 Comparison bronze with solid lubricant and SNS sinter guiding elements | 28     |
| 15. Appendix  | 31     |
| 15.1 Internet and CAD   | 31     |
| 15.2 General description of gas springs                                     | 32     |
| 15.3 Maximal operating conditions for gas springs                           | 33     |
| 15.4 Calculations gas springs   | 34     |
| 15.5 Mounting instructions gas springs                                      | 35     |
| 15.6 Filling pressure list gas springs                                      | 36     |
| 16. Exploded view and item list   | 40     |

## PowerMax cam unit SN5650-PMU-0065 – SN5650-PMU-0260

### Preamble

Thank you for the confidence in the product of **STRACK NORMA GmbH & Co. KG**

We are pleased about your decision to buy a product of **STRACK**. To facilitate the handling with the product, we established these operating instructions.

The operating instructions are an important element to the side cam unit **SN5650-PMU** and provide the secure and efficient operating. It is intended for all persons which are working with these cam units and which are responsible for the secure operating.

For reasons of the operating safety a copy of these operating instructions has to be left at the side cam unit to guarantee the direct access for the operating personnel.

The security advices in the operating instructions have particularly been respected to recognize and to avoid possible dangers. Please read the operating instructions carefully and completely before mounting and initial operation of the side cam unit **SN5650**.

A regular maintenance is necessary to guarantee a secure and economic application.

If the instructions and advices of these operating instructions are not observed, any liability on our part for resulting damages and performance losses will be excluded.

## PowerMax cam unit SN5650-PMU-0065 – SN5650-PMU-0260

### 1. Security advices. Please absolutely consider!

Before mounting and initial operation and all further works at the **STRACK PowerMax cam** please absolutely read the following safety instructions.

The cam has to be used according to these operating instructions. If new operating instructions will be established, this version loses its validity.

Service and maintenance works at the mounted **STRACK** nitrogen-gas springs may only be effected by persons trained and instructed by **STRACK NORMA** with good professional knowledge.

If the mounted **STRACK** nitrogen-gas spring is used incorrectly or not for the intended application, menace:

Dangers for the health

Dangers for the **STRACK** nitrogen-gas springs  
and other property holdings of the operator,

Dangers for the efficiency of the **STRACK** nitrogen-gas springs.

For all operations at the **STRACK** side cam, the valid Ordinance on Industrial Safety and Health paragraph 3 has to be considered.

Press, tool and peripheral devices have to be suited, prepared and adjusted for the application of the **STRACK** side cams.



#### Attention:

Before and during the service- and maintenance operations at the tool respectively at the **STRACK cam** there is an increased risk of accident. Therefore these operations may only be effected at cam units which are driven back.

Seized cam units at faultless gas springs can cause an abrupt decompression. Thus they can be an injury risk.

Damaged gas spring may not be used again. The exchange of individual parts has to be agreed with **STRACK NORMA**.

## PowerMax cam unit SN5650-PMU-0065 – SN5650-PMU-0260

### 2. After receipt of delivery

Before opening, please check the delivery concerning damages. Please reclaim damages directly at the transport company, which has delivered the consignment.

Please compare the content of the consignment with the delivery note respectively the enclosed list of items (see appendix). Please also ascertain that all parts are present and unpacked.

**Not till then dispose of the transport- and packing material.**

If the content is damaged without visible damage of the packing material, please do not return it for repair or exchange.

Please contact **STRACK NORMA GmbH & Co.KG**, Lüdenscheid, to get further information.

Phone: 02351 / 8701 - 0   reception  
                                  - 252 Mr. Müller

## PowerMax cam unit SN5650-PMU-0065 – SN5650-PMU-0260

### 3. Characteristics

The execution of this STRACK cam unit is a “side cam unit type SN5650”.

These cams can be mounted: - without mounting plate as “Basis” and “Medium” version  
- with mounting plate as “Premium version”

These PowerMax cam units consists of:

- cam retainer
- cam body
- driver

with the corresponding accessories

All PowerMax cam units are equipped with gas springs.

In this system, nitrogen with a purity grade of  $\geq 99.8$  vol.-% is used as active fluid medium for the gas springs.

The cylinder dimension, cylinder number and filling pressure (different at the diverse cam types) determine the reset force which is available.

Please consider that all PowerMax cam units are the successful result of a long development work. The resulting advantages optimally develop at the full exploitation of the respective cam stroke during the work process; that means, the stamping- and benching operation of the cam unit should be carried out in the front end position.

The complete exploitation of the cam stroke allows the maximal intervention of the active return and the therewith connected highest possible supply of retracting- and stripper forces (about 10 % of the pressing force).

In the front endpoint of the cam stroke there is the maximal retraction of the gas spring. Generally applies: The construction and the resulting values, like assembly height and restoring forces, require that the cam unit is mounted in the front end position.



## PowerMax cam unit SN5650-PMU-0065 – SN5650-PMU-0260

### 3.1 Description of the construction types

Unique in the world is the differentiation of a cam program in 3 types:  
**BASIS, MEDIUM, PREMIUM.**

These types which are totally similar in the dimensions differ exclusively in their performance values and the equipment details.

The **BASIS** cam is equipped with guide elements out of bronze-graphite. The working surface is out of cast iron.

The **MEDIUM** cam is equipped with guide elements out of sintermetal, the working surface is out of cast iron and the active return can be adjusted.

The **PREMIUM** cam is equipped with guide elements out of sintermetal, the working surface is a removable mounting plate and the active return can be adjusted.



#### **Attention:**

The mounted gas springs serve for the additional reset of the cam slide.  
The working powers which are necessary for the operation are absorbed by the active return (only Medium- and Premium version).

### 4. Scope of delivery

The **PowerMax** cam units are delivered preassembled and with a precise guide clearance.

The mounted gas springs, unless otherwise desired, are delivered with maximal filling pressure.

The working surface can already contain client-specific insertions. Also Premium special mounting plates belong to these.

All cams can also be produced for the machining of high strength sheets, contrary to the angles in five steps described in the catalogue, in all intermediate angles according to customers' requirements.

Please contact us.

### PowerMax cam unit SN5650-PMU-0065 – SN5650-PMU-0260

## 5. Design of the PowerMax cams

STRACK NORMA Power Max cams are produced in a high-precision manner.

The guidances which are grinded to a tight guide clearance allow highest loads. The cam units can be equipped with the tool on the working surface. In doing so you have to consider that the force affects in the centre of the working surface.

If you have an off-center load irregular forces arise on the guidances and produce an increased wear.  
(See 3.1. description of the construction types)

SN5650-PMU-0230-20°-B-N/Z

|   |    |     |     |     |     |     |     |     |    |    |  |
|---|----|-----|-----|-----|-----|-----|-----|-----|----|----|--|
| 71  | 71 | 83  | 109 | 146 | 211 | 146 | 109 | 83  | 71 | 71 |  |
| 77  | 77 | 94  | 129 | 181 | 286 | 181 | 129 | 94  | 77 | 77 |  |
| 77  | 77 | 103 | 144 | 206 | 343 | 206 | 144 | 103 | 77 | 77 |  |
| 82  | 82 | 110 | 157 | 231 | 411 | 231 | 157 | 110 | 82 | 82 |  |
| 86  | 86 | 117 | 171 | 263 | 522 | 263 | 171 | 117 | 86 | 86 |  |
| 84  | 84 | 113 | 164 | 248 | 471 | 248 | 164 | 113 | 84 | 84 |  |
| 79  | 79 | 106 | 151 | 219 | 378 | 219 | 151 | 106 | 79 | 79 |  |
| 78  | 78 | 99  | 137 | 196 | 322 | 196 | 137 | 99  | 78 | 78 |  |
| <p style="text-align: center;"> <span style="margin-right: 20px;">3 x 25</span> <span style="margin-right: 20px;">17,5</span> <span style="margin-right: 20px;">3 x 15</span> <span style="margin-right: 20px;">17,5</span> <span style="margin-right: 20px;">3 x 25</span> </p> <p style="text-align: center;">230</p> |    |     |     |     |     |     |     |     |    |    |  |

● F max. = 568 kN

Herefrom you can clearly read the maximal force outside the centre of activity for the x respectively the y axis. Modifications of position which will be possible in future should be considered previously to choose a cam size which corresponds to the force.

To be able to guarantee an equal running life, the load forces reduce, according to the position, on the working face.

You will find detailed information in the catalogue indications concerning to your cam in the internet under:

[www.strack.de](http://www.strack.de)

**Basis** <750.000 strokes

**Medium** >1.000.000 strokes

**Premium** >1.000.000 strokes



#### Attention:

If the cam should be superstructured with accessories a new calculation is necessary.  
Please contact us.



### PowerMax cam unit SN5650-PMU-0065 – SN5650-PMU-0260

## 6. Preparation of tool and press

Tool, press and peripheral devices have to be suited, prepared and adapted according to the indications of **STRACK NORMA** for the utilisation of the **PowerMax cam** unit.

Drain off fluid (for example water or drawing compounds) well-directed by drainage. You have to take care that punching wastes don't fall in or on the cam guidance.

Cam slide and guidances can seize. Parts falling down can damage the guidances, hereby possibly the running life of the cam reduces. If there is a failure, the cam slide can't be placed back in the initial position.

## 7. Shouldering

The force distribution of the individual forces in the cams depends on the right shouldering in the tool and the cam angle.

If the heights  $h_1$  and  $h_2$  (see the picture below) reduce in the tool, the forces of the shouldering can't be completely absorbed.

You will find detailed information in the catalogue indications concerning your cam in the internet under [www.strack.de](http://www.strack.de)

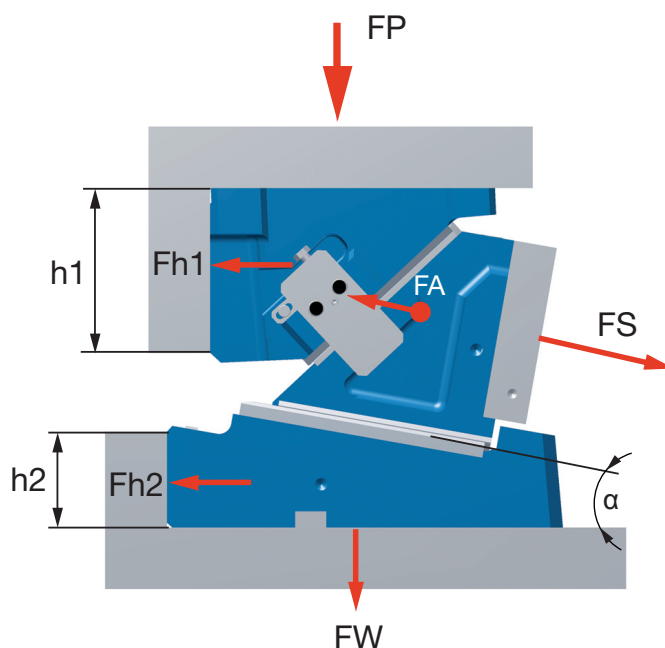

### PowerMax cam unit SN5650-PMU-0065 – SN5650-PMU-0260

## 8. Production

During the production no particular precautionary measures have to be taken, which exceed the valid operating safety regulations paragraph 3.



All data  
without guarantee.

#### Attention:

If attachments are removed during the assembly process, they must be secured again with Loctite 242.

Notes on tightening torques:

| Screws<br>DIN EN ISO 4762-10.9 | M6 | M8 | M10 | M12 | M16 | M20 |
|--------------------------------|----|----|-----|-----|-----|-----|
| Tightening torque [Nm]         | 14 | 33 | 65  | 121 | 302 | 590 |



#### Advice:

Please secure that the **STRACK** cams especially the gas springs are not dipped in fluid.

If you are using for example aggressive drawing oils during the production, make a controlled drain for them (drainage borings, cutouts and so on), so that the fluids are directed away from the gas springs.

Thereby seal damages are avoided.



#### Tip:

Control the nitrogen pressure of the gas springs in regular intervals, to detect changes in the pressure level in time. During maintenance works you have to consider a correct return of the cam slide.



#### Advice:

The cam units are equipped with low-maintenance slide elements out of bronze with solid lubricant. In normal case lubrication is not necessary.

A lubrication may only be effected in case of need with the following lubricants:

| Company | Oils         | Greases         |
|---------|--------------|-----------------|
| AGIP    | Potra ATF    | Agip GR MU 2    |
| BP      | Autran DX II | Energrease      |
| ESSO    | ATF Suffix A | Nebula EP 2     |
| ESSO    | ATF - D      | Beacon EP 2     |
| OMV     | ATF Serie    | OMV signum CX 2 |
| SHELL   | Donax TM     | Retinax LX      |
| SHELL   | Donax TF     |                 |

### PowerMax cam unit SN5650-PMU-0065 – SN5650-PMU-0260

#### 8.1 Handling with safety ring bolt (SN1594)

Beginning from the cam units 260, cam retainers and slides can simplified be mounted together by means of the safety ring bolt SN1594, because of the fact that the different positions of the handling screwing thread facilitates the mounting of the cam slide in the slide retainer.

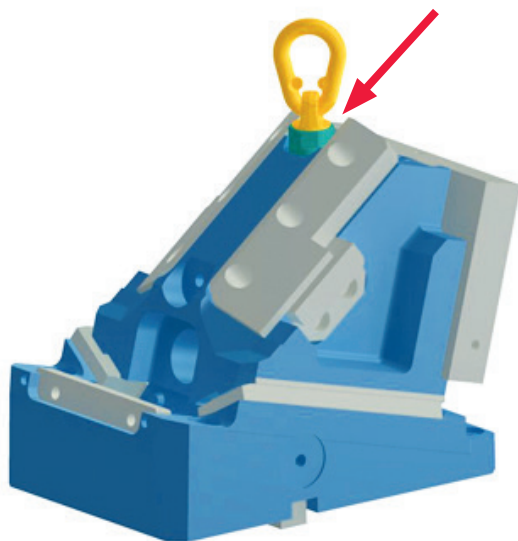
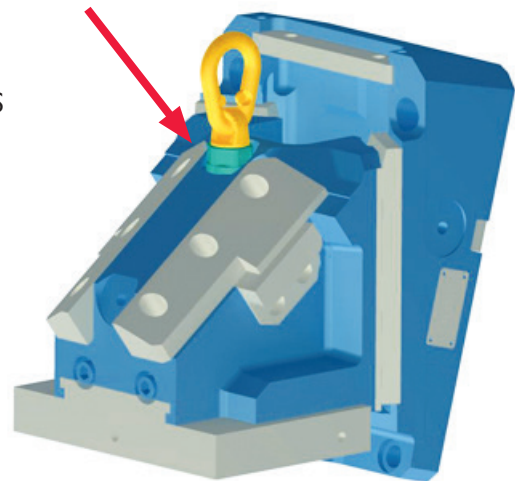

By changing the position of the safety ring bolt, the cam retainer and the cam slide can be simpler mounted together into the tool.

Mounting of the cam retainer with the cam slide in the tool with lateral thread for the flexible mounting and turning of the cam.

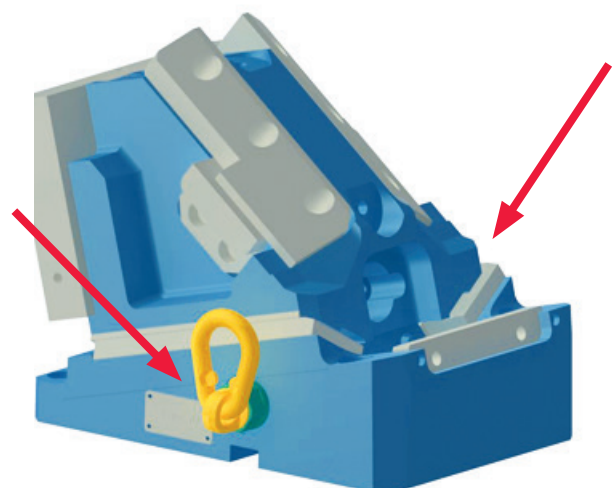

### PowerMax cam unit SN5650-PMU-0065 – SN5650-PMU-0260

## 8.2 Marking of the cams

All PowerMax cams are equipped with a type plate.

On this type plate the name and the serial number of the cam are lasered.

| STRACK®<br>NORMALIEN              |   | PowerMax® |                            |
|-----------------------------------|---|-----------|----------------------------|
| Name of the cam                   | → | Norm:     | SN5650-PMU-0065-25-B-N-V01 |
| 6-digit serial number             | → | Serie:    | Sn.-Nr.: 1 2 3 4 5 6       |
| For additional information        | → |           |                            |
| for customers                     | → |           |                            |
| <b>Gasdruckfeder montiert!</b>    |   |           |                            |
| <b>Mat.: EN-GJS-600-3 (GGG60)</b> |   |           |                            |

The serial number refers to all cams of an order and is different concerning order to order. The Power Max cams were adjusted in the company STRACK. For this the hardened steel guide strips were ground to the corresponding dimension. The appropriate screws were additionally secured by the screw locking adhesive Z9093.

**Attention:** Don't remove the rails. If this should be inevitable in a case of a crash, the replacement strips have to be adjusted again.

To avoid confusions within a series the assembly groups of the individual cams are marked within the series with numbers of 1 to ... (see picture below). During the mounting please absolutely consider the right coordination of the components to avoid problems.

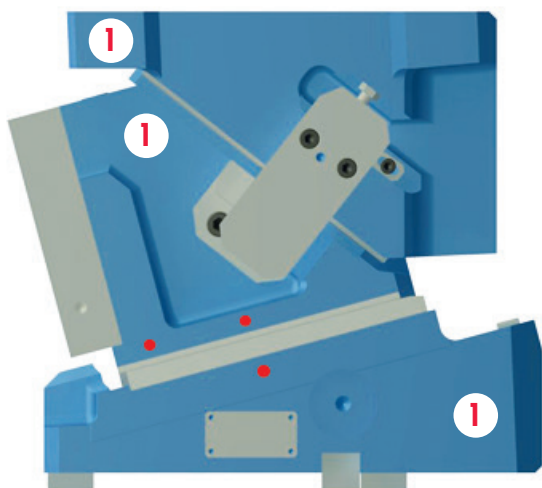

Additional markings on slide retainer and slide body make it possible to control the position of the cam in the tool.

If the cam is moved together, the upper markings correspond; if the cam is extended the lower markings correspond.

If the marking on the cam retainer is between the marking of the body, the whole cam is not driven back in the correct initial position.

### PowerMax cam unit SN5650-PMU-0065 – SN5650-PMU-0260

#### 9. Dismounting of the mounting plate at cam widths 0065-0260 (only Premium)

The **PREMIUM** version of the **PowerMax®** is equipped with a demountable mounting plate, which makes a simpler handling possible.

The high-precision plate can be dismounted easily to be able to carry out further machining.

##### Step 1

Loose and remove the securing screw on the top side (picture 1).

##### Step 2

Push the mounting plate out of the precision nut guidance (picture 2).

Now you can carry out further machining at your mounting plate.

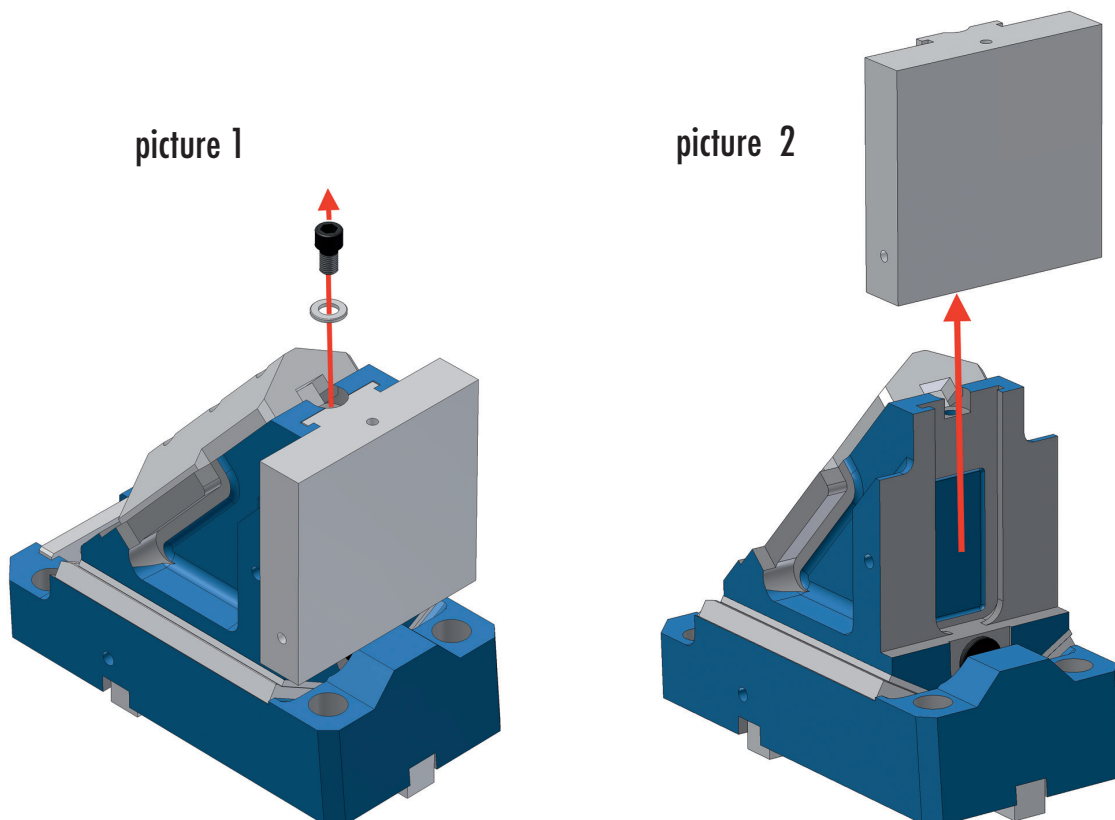

### PowerMax cam unit SN5650-PMU-0065 – SN5650-PMU-0260

#### 9.1 Mounting of the mounting plate at cam widths 0065-02030 (only Premium)

##### Step 1

Before pushing the mounting plate back in the groove guidance it is absolutely necessary to clean the stop lug (AN) and the t-nut guidance of both components.

##### Step 2

Fix the mounting plate with the securing screw again.

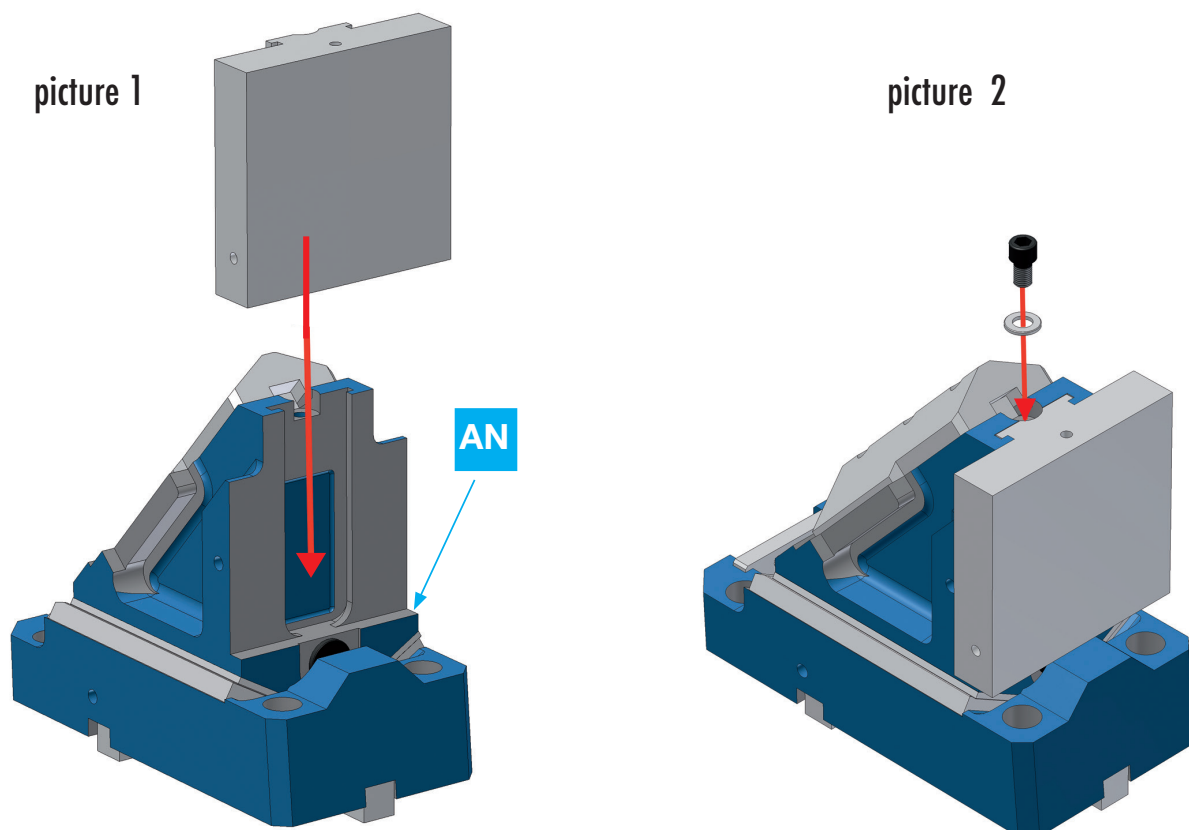



### PowerMax cam unit SN5650-PMU-0065 – SN5650-PMU-0260

## 10. The Lock-Out-Systems

---

### 10.1 Lock-Out-System SN5651-LOS

This lock-out system can be used at mounted and dismantled standard cams.

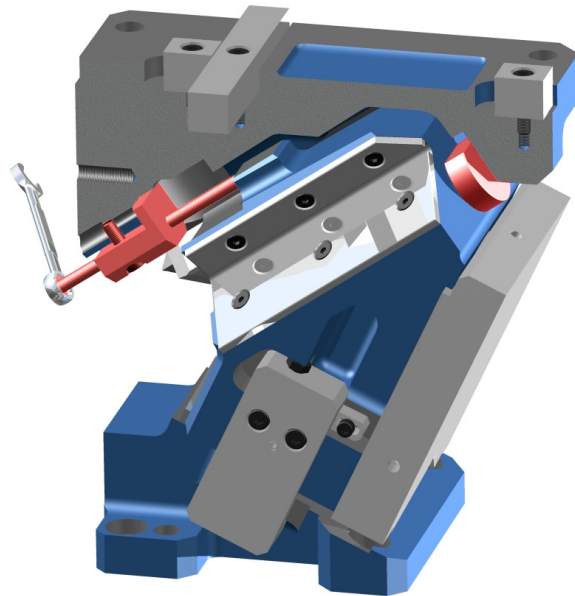

### 10.2 Lock-Out-System SN5654-LOS

This lock-out system can only be used at dismantled standard cams.

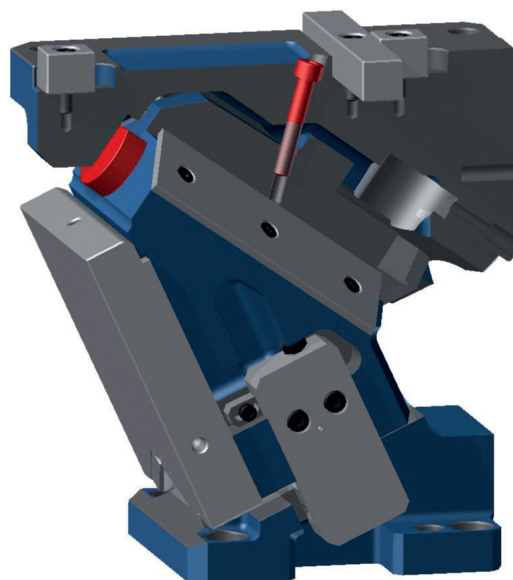

### PowerMax cam unit SN5650-PMU-0065 – SN5650-PMU-0260

#### 10. Lock-Out-System SN5651-LOS

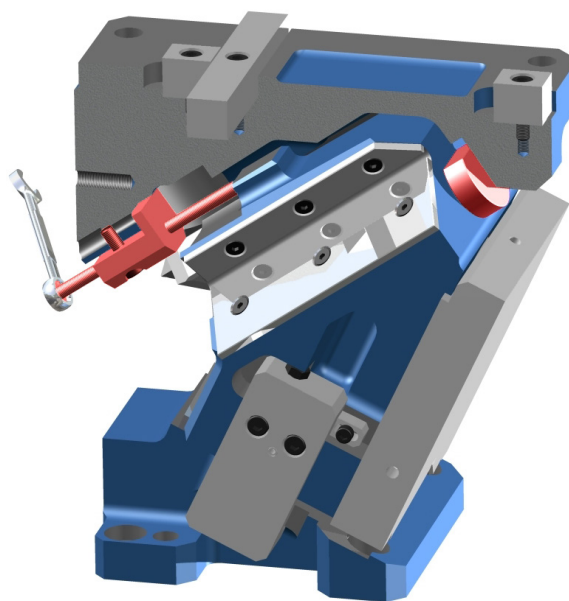
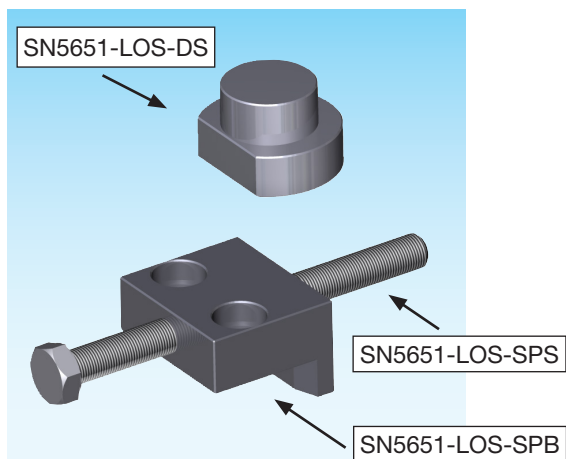

#### SN5651-LOS



SN5651-LOS-Type



Mat.: ST

further details under: [www.strack.de](http://www.strack.de)

| Type                | for cam         | SN5651-PMU-LOS-SPB | SN5651-LOS-SPS         | SN5651-LOS-DS |
|---------------------|-----------------|--------------------|------------------------|---------------|
| SN5651-PMU-LOS-0065 | SN5651-PMU-0065 | 0                  | SN5651-LOS-SPS-M6x90   | 2             |
| SN5651-PMU-LOS-0090 | SN5651-PMU-0090 | 0                  | SN5651-LOS-SPS-M8x90   | 2             |
| SN5651-PMU-LOS-0125 | SN5651-PMU-0125 | 0                  | SN5651-LOS-SPS-M8x90   | 2             |
| SN5651-PMU-LOS-0165 | SN5651-PMU-0165 | 0                  | SN5651-LOS-SPS-M10x120 | 2             |
| SN5651-PMU-LOS-0230 | SN5651-PMU-0230 | 0                  | SN5651-LOS-SPS-M12x120 | 2             |
| SN5651-PMU-LOS-0230 | SN5651-PMU-0260 | 0                  | SN5651-LOS-SPS-M12x120 | 2             |

### PowerMax Schiebereinheit SN5650-PMU-0065 – SN5650-PMU-0260

#### 10.1 Mounting of the Lock-Out-System SN5651-LOS

To fasten the cam for the insertion of borings, the fixation of the cam slide by means of a lock-out-system is necessary. For this purpose please act as following.

picture 1

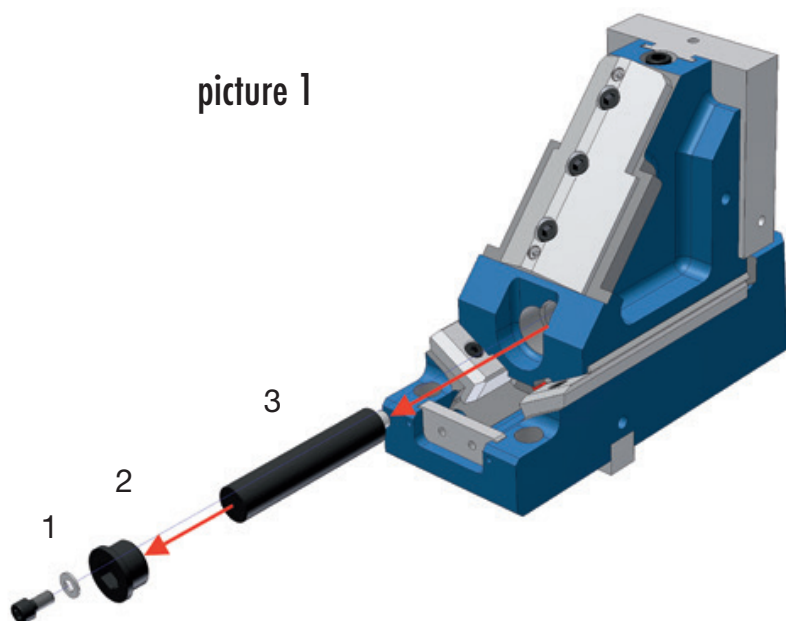

1. Remove the gas spring by removing at first the securing screw (step 1); afterwards remove the plug (step 2). Now you can remove the gas spring (step 3) out of the boring.

picture 2

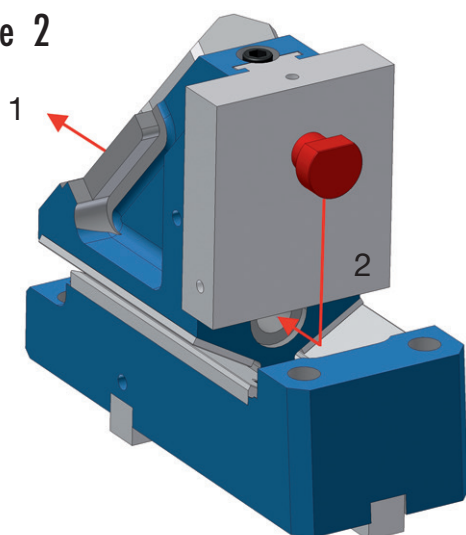

2. Push the slide in the rear position (step 1). Place the distance disc SN5651-LOS-DS in the boring (step 2).

### PowerMax Schiebereinheit SN5650-PMU-0065 – SN5650-PMU-0260

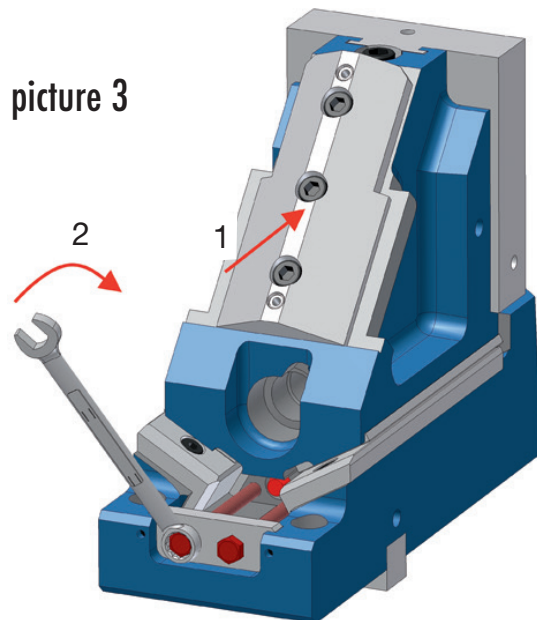

3. Now push the cam slide in the front position (step 1). Turn the screws **SN5651-LOS-SPS-M8 x 90** in the slide top (step 2). Tighten the screws cautiously to fasten the cam slide (step 2).

picture 4

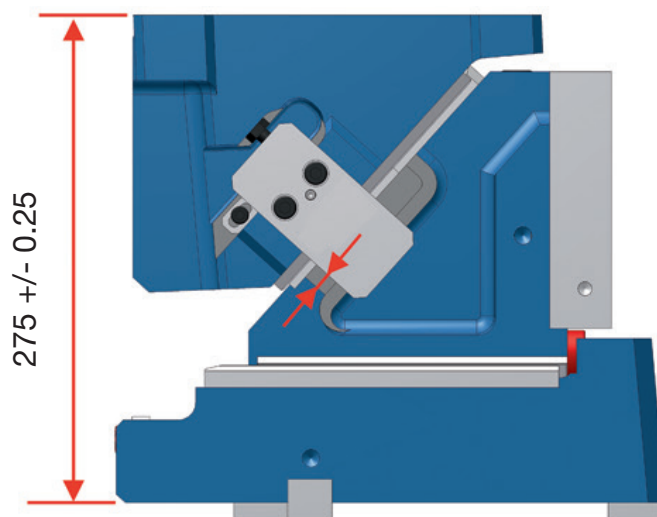

4. The slide has an installation height of 275 +/- 0.25 mm. Put a final dimension (10 mm) between the slide stop and the active return cramp, to get the exact installation height.

### PowerMax Schiebereinheit SN5650-PMU-0065 – SN5650-PMU-0260

#### 10.2 Lock-Out-System SN5654-LOS

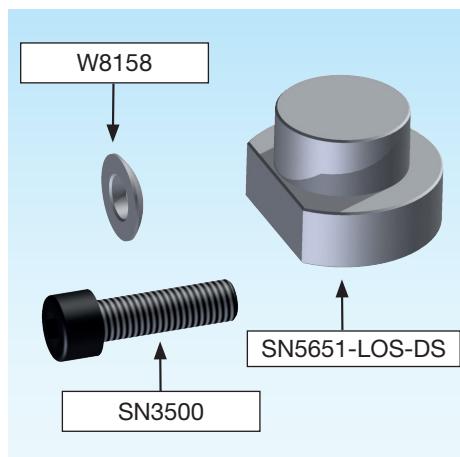

#### SN5654-LOS



SN5654-LOS-Type



Mat.: ST

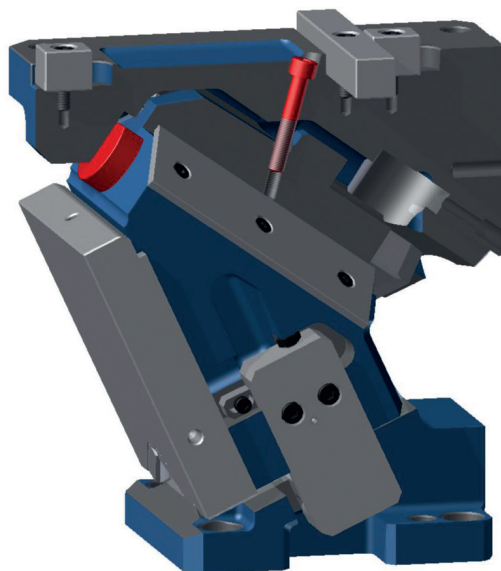

further details under: [www.strack.de](http://www.strack.de)

| Type                   |     | Screw         | Number | Screw | Number | Locking heel        | Number | Ball washer       | Number |
|------------------------|-----|---------------|--------|-------|--------|---------------------|--------|-------------------|--------|
| <b>PMU 0065</b>        |     |               |        |       |        |                     |        |                   |        |
| SN5654-PMU-LOS-0065-00 | 00° | SN3500-M10-35 | 1      | -     | -      | SN5651-LOS-DS-19x15 | 1      | SN5654-PMU-LOS-KS | 1      |
| SN5654-PMU-LOS-0065-05 | 05° | SN3500-M10-35 | 1      | -     | -      | SN5651-LOS-DS-19x15 | 1      | SN5654-PMU-LOS-KS | 1      |
| SN5654-PMU-LOS-0065-10 | 10° | SN3500-M10-35 | 1      | -     | -      | SN5651-LOS-DS-19x15 | 1      | -                 | -      |
| SN5654-PMU-LOS-0065-15 | 15° | SN3500-M10-35 | 1      | -     | -      | SN5651-LOS-DS-19x15 | 1      | -                 | -      |
| SN5654-PMU-LOS-0065-20 | 20° | SN3500-M10-40 | 1      | -     | -      | SN5651-LOS-DS-19x15 | 1      | -                 | -      |
| SN5654-PMU-LOS-0065-25 | 25° | SN3500-M10-45 | 1      | -     | -      | SN5651-LOS-DS-19x15 | 1      | -                 | -      |
| <b>PMU 0090</b>        |     |               |        |       |        |                     |        |                   |        |
| SN5654-PMU-LOS-0090-00 | 00° | SN3500-M10-35 | 1      | -     | -      | SN5651-LOS-DS-19x15 | 1      | SN5654-PMU-LOS-KS | 1      |
| SN5654-PMU-LOS-0090-05 | 05° | SN3500-M10-35 | 1      | -     | -      | SN5651-LOS-DS-19x15 | 1      | SN5654-PMU-LOS-KS | 1      |
| SN5654-PMU-LOS-0090-10 | 10° | SN3500-M10-35 | 1      | -     | -      | SN5651-LOS-DS-19x15 | 1      | -                 | -      |
| SN5654-PMU-LOS-0090-15 | 15° | SN3500-M10-35 | 1      | -     | -      | SN5651-LOS-DS-19x15 | 1      | -                 | -      |
| SN5654-PMU-LOS-0090-20 | 20° | SN3500-M10-40 | 1      | -     | -      | SN5651-LOS-DS-19x15 | 1      | -                 | -      |
| SN5654-PMU-LOS-0090-25 | 25° | SN3500-M10-45 | 1      | -     | -      | SN5651-LOS-DS-19x15 | 1      | -                 | -      |

### PowerMax Schiebereinheit SN5650-PMU-0065 – SN5650-PMU-0260

| Type                   |     | Screw         | Number | Screw | Number | Locking heel        | Number | Ball washer       | Number |
|------------------------|-----|---------------|--------|-------|--------|---------------------|--------|-------------------|--------|
| <b>PMU 0125</b>        |     |               |        |       |        |                     |        |                   |        |
| SN5654-PMU-LOS-0125-00 | 00° | SN3500-M10-35 | 1      | -     | -      | SN5651-LOS-DS-25x15 | 1      | SN5654-PMU-LOS-KS | 1      |
| SN5654-PMU-LOS-0125-05 | 05° | SN3500-M10-35 | 1      | -     | -      | SN5651-LOS-DS-25x15 | 1      | SN5654-PMU-LOS-KS | 1      |
| SN5654-PMU-LOS-0125-10 | 10° | SN3500-M10-40 | 1      | -     | -      | SN5651-LOS-DS-25x15 | 1      | -                 | -      |
| SN5654-PMU-LOS-0125-15 | 15° | SN3500-M10-45 | 1      | -     | -      | SN5651-LOS-DS-25x15 | 1      | -                 | -      |
| SN5654-PMU-LOS-0125-20 | 20° | SN3500-M10-55 | 1      | -     | -      | SN5651-LOS-DS-25x15 | 1      | -                 | -      |
| SN5654-PMU-LOS-0125-25 | 25° | SN3500-M10-55 | 1      | -     | -      | SN5651-LOS-DS-25x15 | 1      | -                 | -      |
| <b>PMU 0165</b>        |     |               |        |       |        |                     |        |                   |        |
| SN5654-PMU-LOS-0165-00 | 00° | SN3500-M10-35 | 1      | -     | -      | SN5651-LOS-DS-32x15 | 1      | SN5654-PMU-LOS-KS | 1      |
| SN5654-PMU-LOS-0165-05 | 05° | SN3500-M10-35 | 1      | -     | -      | SN5651-LOS-DS-32x15 | 1      | SN5654-PMU-LOS-KS | 1      |
| SN5654-PMU-LOS-0165-10 | 10° | SN3500-M10-40 | 1      | -     | -      | SN5651-LOS-DS-32x15 | 1      | -                 | -      |
| SN5654-PMU-LOS-0165-15 | 15° | SN3500-M10-45 | 1      | -     | -      | SN5651-LOS-DS-32x15 | 1      | -                 | -      |
| SN5654-PMU-LOS-0165-20 | 20° | SN3500-M10-55 | 1      | -     | -      | SN5651-LOS-DS-32x15 | 1      | -                 | -      |
| SN5654-PMU-LOS-0165-25 | 25° | SN3500-M10-55 | 1      | -     | -      | SN5651-LOS-DS-32x15 | 1      | -                 | -      |
| <b>PMU 0230</b>        |     |               |        |       |        |                     |        |                   |        |
| SN5654-PMU-LOS-0230-00 | 00° | SN3500-M12-40 | 1      | -     | -      | SN5651-LOS-DS-32x20 | 1      | -                 | -      |
| SN5654-PMU-LOS-0230-05 | 05° | SN3500-M12-40 | 1      | -     | -      | SN5651-LOS-DS-32x20 | 1      | -                 | -      |
| SN5654-PMU-LOS-0230-10 | 10° | SN3500-M12-45 | 1      | -     | -      | SN5651-LOS-DS-32x20 | 1      | -                 | -      |
| SN5654-PMU-LOS-0230-15 | 15° | SN3500-M12-50 | 1      | -     | -      | SN5651-LOS-DS-32x20 | 1      | -                 | -      |
| SN5654-PMU-LOS-0230-20 | 20° | SN3500-M12-60 | 1      | -     | -      | SN5651-LOS-DS-32x20 | 1      | -                 | -      |
| SN5654-PMU-LOS-0230-25 | 25° | SN3500-M12-60 | 1      | -     | -      | SN5651-LOS-DS-32x20 | 1      | -                 | -      |
| <b>PMU 0260</b>        |     |               |        |       |        |                     |        |                   |        |
| SN5654-PMU-LOS-0260-00 | 00° | SN3500-M12-40 | 1      | -     | -      | SN5651-LOS-DS-32x20 | 1      | -                 | -      |
| SN5654-PMU-LOS-0260-05 | 05° | SN3500-M12-40 | 1      | -     | -      | SN5651-LOS-DS-32x20 | 1      | -                 | -      |
| SN5654-PMU-LOS-0260-10 | 10° | SN3500-M12-45 | 1      | -     | -      | SN5651-LOS-DS-32x20 | 1      | -                 | -      |
| SN5654-PMU-LOS-0260-15 | 15° | SN3500-M12-50 | 1      | -     | -      | SN5651-LOS-DS-32x20 | 1      | -                 | -      |
| SN5654-PMU-LOS-0260-20 | 20° | SN3500-M12-60 | 1      | -     | -      | SN5651-LOS-DS-32x20 | 1      | -                 | -      |
| SN5654-PMU-LOS-0260-25 | 25° | SN3500-M12-60 | 1      | -     | -      | SN5651-LOS-DS-32x20 | 1      | -                 | -      |



### PowerMax Schiebereinheit SN5650-PMU-0065 – SN5650-PMU-0260

#### 10.2.1 Information about Lock-Out-System SN5654-LOS

##### Distribution of force:

The new developed lock out system makes it possible to fix the corresponding standard cam free of play in its front end position. In doing so, the cam body is screwed with the cam reception. The special thing is that the clamping screws act under an angle on the corresponding bearing face.

That means the cam body is once pulled by the divided (resulting) force against the prismatic arranged guide rails and at the same time is pulled against the pressure piece.

Now the cam body is positioned free of play exactly in its front end position and is prepared for additional machining.

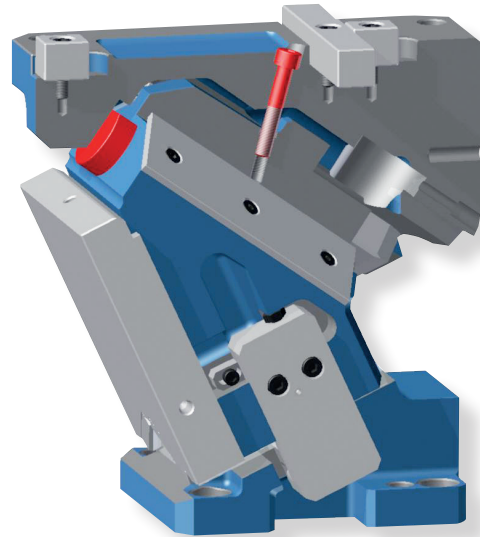

Please consider that the Lock-out-System can only be used in dismounted standard cams.

At the most Power-Max standard cams the fixing holes are partly covered, if the cam body is in the front end position.

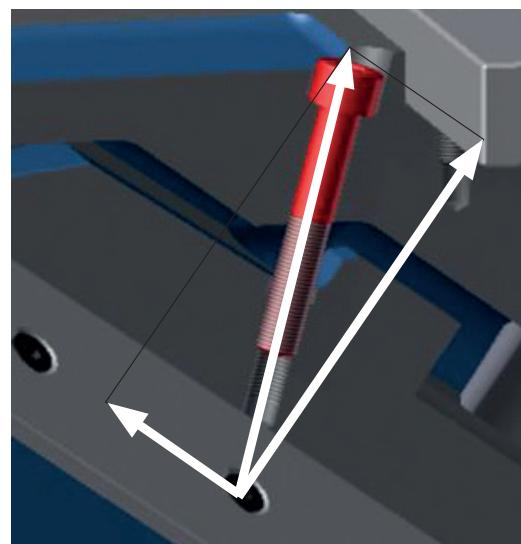
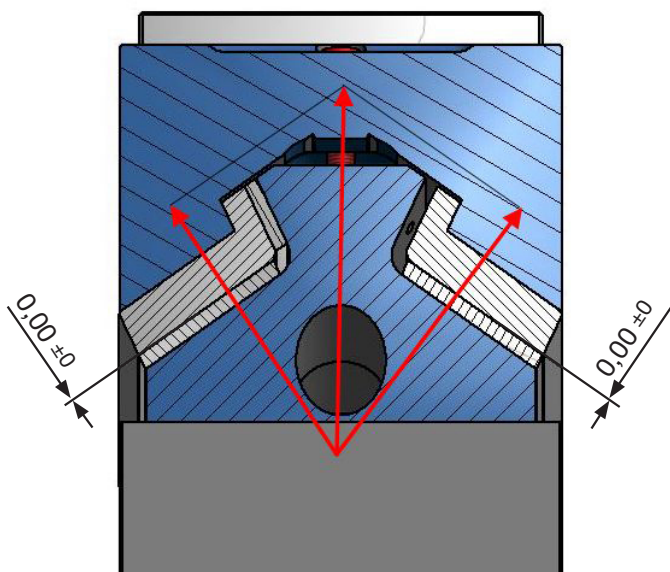

### PowerMax cam unit SN5650-PMU-0065 – SN5650-PMU-0260

## 11. Dismounting / Mounting of the gas springs

To remove the gas spring out of the cam, at first the safety bolt and the closing plug have to be dismantled.

The mounting is effected in the reverse order. For this the cam slide has to be pushed back to be able to turn the plug in. Afterwards the plug has to be secured with the safety bolt and the washer.

 Observe notes on point 8. production!

### 1. Removing of the gas springs

picture 1

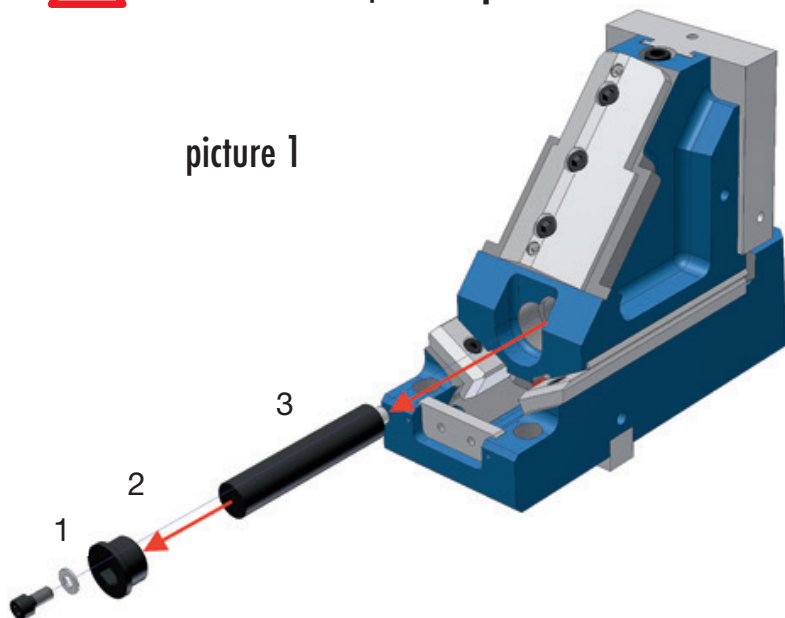

### 2. Mounting of the gas springs

Insert the gas spring into the hole provided. Screw the sealing plug into the sealing thread. If necessary, lift the slide body for this purpose until the thread of the plug engages.

Place the lock washer in the recess and screw in the screw. Tighten the screw to 33 Nm.

#### ATTENTION!

Use Loctite 243 medium strength to secure the screw.

To ensure disassembly under the press, do not secure the screw plug with Loctite.

picture 2

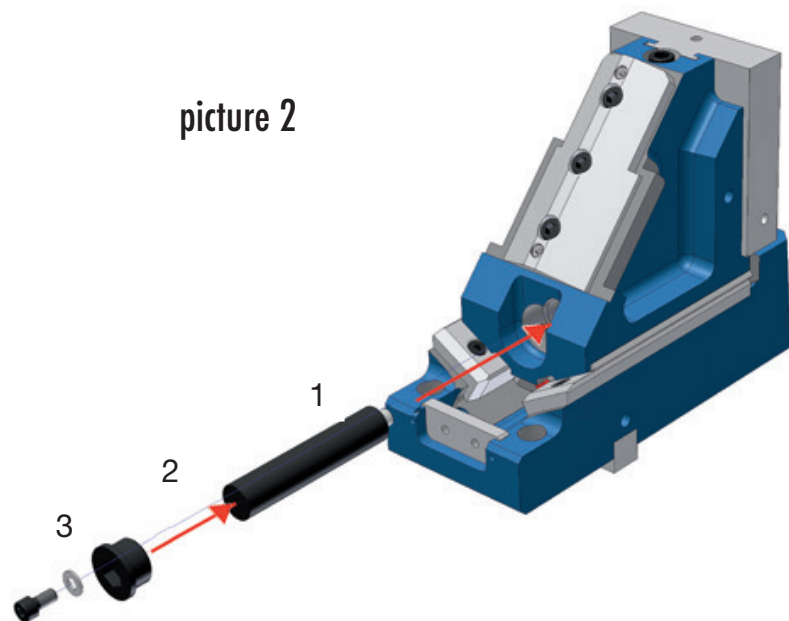

### PowerMax cam unit SN5650-PMU-0065 – SN5650-PMU-0260

## 12. Modification of the system pressure of the gas springs

### 12.1 Discharging of the pressure at a gas spring

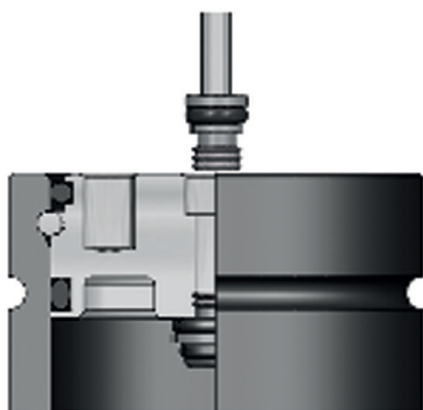

1. If necessary remove the closing plug.

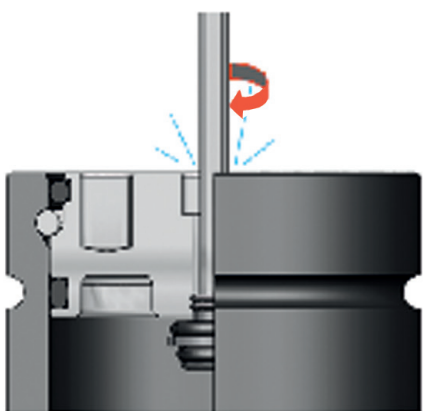

2. To loose the valve, use a 3 mm socket wrench. Turn it to the right till the gas escapes (1-2 turns).



3. As soon as the gas spring is discharged, turn the valve to the left till the initial position is reached. The gas spring is ready to be charged.

### PowerMax cam unit SN5650-PMU-0065 – SN5650-PMU-0260

## 12.2 Increase of pressure / Charging of a gas spring

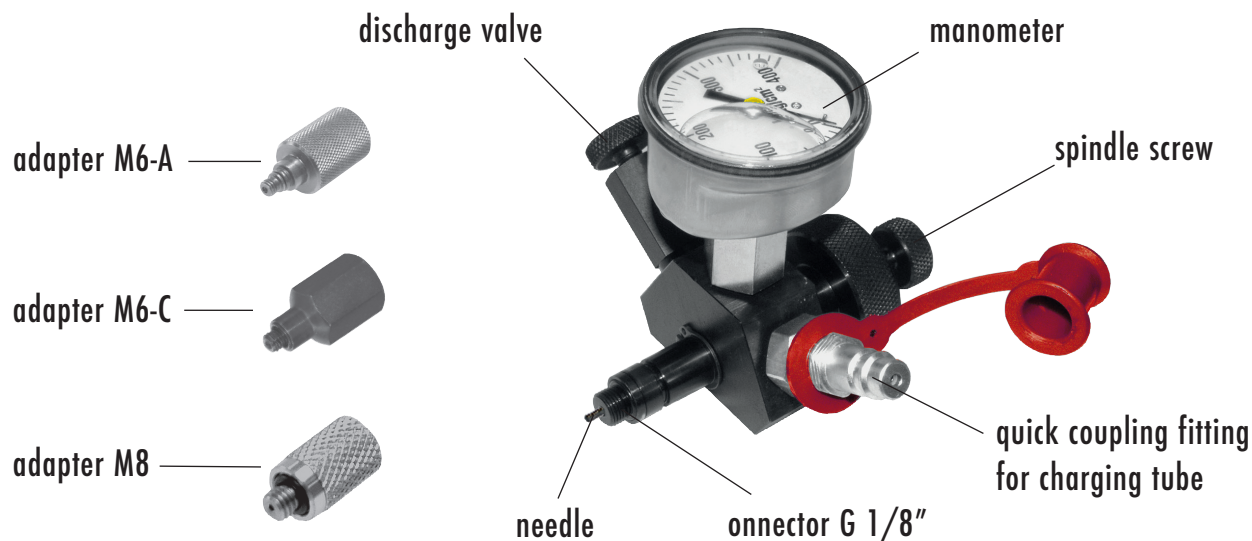

**Attention!**  
Please consider

Minimum pressure 25 bar  
Maximum pressure 175 bar

### Charging of gas springs

For gas springs with connector thread G1/8":

1. Turn the spindle screw back till the needle ends flush in the centre of the connector G1/8".
2. Turn the charging equipment with the connector G1/8" in the gas spring. Continue with step 3.

For the gas springs with the connecting thread M6-A/M8:

- 2a Turn the adapter M6-A/M8 on the connecting thread G1/8".
- 2b Turn the charging equipment with the connector M6 in the gas spring. Continue with step 3.

3. Plug the coupling of the charging tube to the quick coupling fitting.
4. Open slowly the valve at the charging tube till the manometer shows the desired pressure (close the valve).
5. The valve in the gas spring closes automatically. To discharge the pressure which is still in the charging equipment, turn the screw of the discharging valve slowly till the residual pressure escapes. Finally turn the adjusting screw of the discharging valve immediately back to its initial position.
6. Turn the charging equipment out of the gas spring.

### PowerMax cam unit SN5650-PMU-0065 – SN5650-PMU-0260

#### Pressure monitoring of gas springs with connecting thread G1/8"

1. Turn the spindle screw back as far as in the centre of the connector G1/8" the needle closes flush (picture 1).
2. Turn the charging equipment with the connector G1/8" in the gas spring.
3. By turning the spindle screw the needle opens the valve in the gas spring and the pressure is indicated at the manometer.

⚠ Pressure monitoring of gas springs with connecting thread M6 is not possible!

#### Release or reduce pressure at gas springs with connecting thread G1/8"

1. Act as in step 1-3 concerning the pressure monitoring of gas spring with connecting thread G1/8".
2. To release the pressure, which is in the gas spring, turn the screw of the discharge valve slowly in till the pressure escapes or till the desired pressure is indicated at the manometer. Finally turn the adjusting screw of the discharge valve immediately back in the initial position.

⚠ You must be able to press the piston rod down by hand to secure that the gas spring is depressurized! A dismantling of the gas spring may only be effected in a depressurized condition!

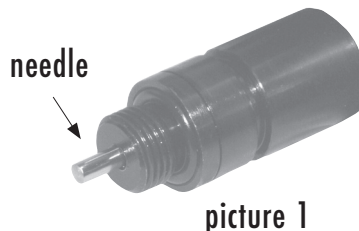

#### Release pressure at gas springs with connecting thread M6

1. Gas springs with a connecting thread M6 can't be discharged with the charging equipment SN2967! The needle of the charging equipment can't be turned through the screwed adapter M6-A.
2. Gas springs of the series SN2900 and SN2910-M16 and SN2910-M24 dispose of a disc valve SN2992. Continue with step 5.
3. To release the pressure of a gas spring with thread M6, use the discharging lug SN2955-M6 (picture 2).
4. The valve can be screwed out of the gas spring with the side B.
5. Please act as described in picture 3. To release the pressure turn the disc valve SN2992 in the clockwise direction, one or two turns, till the gas begins to escape. Stop and wait till the gas has escaped. Finally screw the disc valve in anticlockwise direction to close it again (picture 4).

#### SN2955-M6 discharging lug

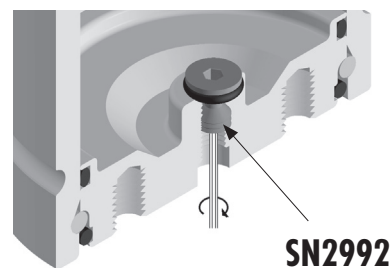
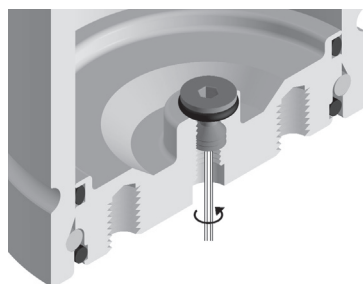
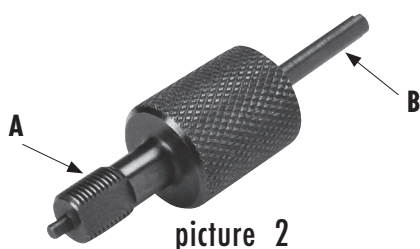

## PowerMax cam unit SN5650-PMU-0065 – SN5650-PMU-0260

### 13. Standstill and storing

#### Standstill

During the standstill of the press no particular precautions have to be taken, which exceed the usual valid regulations at appliances which are actuated with gas springs.

#### Storing

For the transport or storage of the tool with a mounted **STRACK** nitrogen gas spring system, it is reasonable to discharge the system pressure.



Please consider that, according to the construction, components of the tool, during a longer storing, can uncontrollably be pushed together because of the lowering of the system pressure of the gas springs in the cam units (Accident Prevention Regulation).

Please check the system pressure of the gas spring before restarting the tool. If you have to increase the system pressure, act as described in chapter 11.2.

### 14. Maintenance

Guide strips out of steel are hardened and normally are not submitted to any wear.

If necessary these strips are adjusted during the mounting in the company **STRACK** to guarantee a low guide clearance.

The fixing screws of these strips are secured with the bolt adhesive **Z9093**.

The guide strips out of bronze with solid lubricant respectively sintered metal are submitted to a greater wear compared with the steel strips.

The strips are produced in a narrow tolerance range. The exchange of these elements is thus effected without a new adjustment. If both guide partners are exchanged, the guide clearance has to be examined and if necessary has to be adjusted newly.



### PowerMax cam unit SN5650-PMU-0065 – SN5650-PMU-0260

#### 14.1 Adjustment of the active return

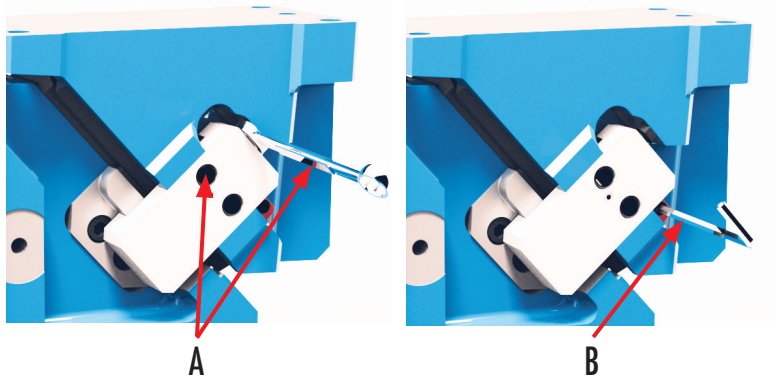

Please ensure that the cam has a secure stand.

Loosen the fixing screws of the active returns (A) and of the adjusting wedge (B).



Pull the adjusting wedge back and put the driver on the prism of the cam slide.

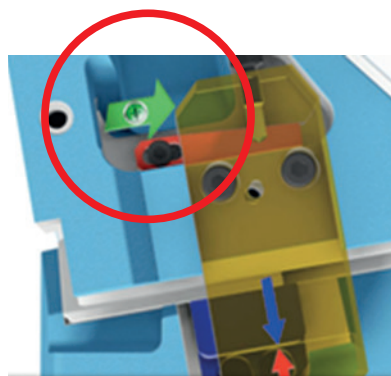

After the installation of the driver on the cam slide push the active returns on the inserts of the driver and fix them by moving the adjusting wedges in the direction of the arrow.

Subsequently fix the screws in the reverse order.

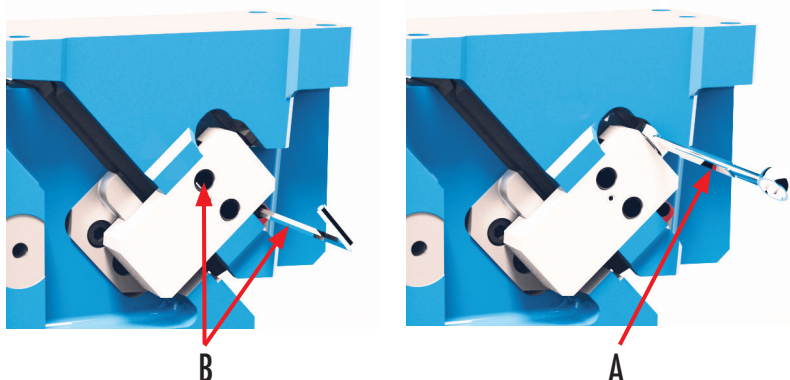

Fix the fastening screws of the adjusting wedges and the active returns, subsequently you secure the active return (A) and control the guide clearance with a 0.01 mm precision calibre band. To avoid a tipping of the driver, both sides should be tightened in the same way.

### PowerMax cam unit SN5650-PMU-0065 – SN5650-PMU-0260

SNS Sintermetall  
SNS sintered metal  
Métal fritté SNS



Maximale Gleitgeschwindigkeit / Maximal sliding speed /  
Vitesse de glissement maximale

40 m/min trocken / dry / sec  
80 m/min geschmiert / lubricated / lubrifié

Reibungskoeffizient / Frictional coefficient / Coefficient de frottement

0,05 - 0,15

PV Wert / PV-value / Valeur PV

2950 daN/cm<sup>2</sup> x m/min

Flächenpressung max. / Surface pressure max. /  
Pression superficielle maximale

76 N/mm<sup>2</sup>

Arbeitstemperatur / Operating temperature /  
Température de travail

< 250 °C trocken / dry / sec  
< 150 °C geschmiert / lubricated / lubrifié  
(in Abhängigkeit vom verwendeten Schmierstoff / dependent from the used  
lubrication / dépendant de la lubrification utilisée)

Porösität der Sintergleitfläche / Porosity of the sinter sliding surface /  
Porosité de la surface de glissement frittée

15 - 25 %

Integrierter Schmierstoff / Integrated lubricant / Lubrifiant intégré

Fe+Cu+Graphit+MoS<sub>2</sub>

Schmierstoffanteil / Portion of lubricant / Part du lubrifiant

15 - 20 %

### PowerMax cam unit SN5650-PMU-0065 – SN5650-PMU-0260

#### Comparison of application

##### Bronze with solid lubricant

##### SNS Sinter metal

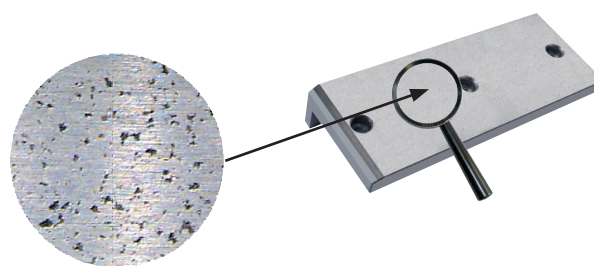
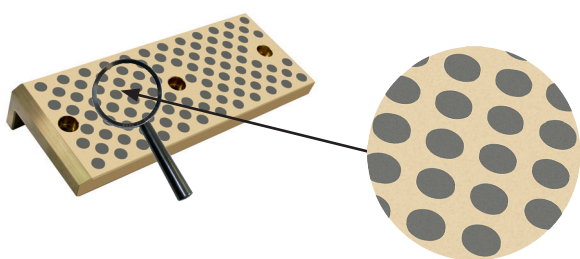

#### Hints

Please consider the lubrication hints to increase the running life of the low-maintenance sliding elements. The guide plates are always engaged with a sliding partner out of hardened steel. Please absolutely avoid damages of the sliding surfaces by impacts on the sliding face or cants during the mounting/dismounting of the cams. Please look after the cleanness of the sliding surfaces. Damages or impurities may possibly lead to scuffing marks during operation. To maintain the soft running you should exchange the low-maintenance slide rails when they are damaged. The hardened steel rails are adapted to the respective guide clearance of the cam and should not be exchanged in the normal case. The low-maintenance sliding elements have a high accuracy, so that replacement rails should be introduced without subsequent work. You will receive exact indications and exploded assembly drawings in the Internet under [www.strack.de](http://www.strack.de)



Low-maintenance sliding elements out of bronze with solid lubricant:

In normal case lubrication is not necessary.

In case of need, lubrication may only be effected with the following lubricants:

The lubricants can also be used for the relubrication of the SNS sinter metal

| Company      | Oils               | max. °C | Fats              | max. °C |
|--------------|--------------------|---------|-------------------|---------|
| STRACK       | Z9084              | 240     | Z9080             | 140     |
| AGIP         | Rotra ATF          | 100     | Agip GR MU 2      | 120     |
| BP           | Autran DX III      | 100     | Energrease        | 140     |
| ESSO / Mobil | ATF 320            | 100     | Nebula EP2        | 120     |
| ESSO / Mobil | ATF 220            | 100     | Beacon EP2        | 130     |
| Castrol      | ATF DEX II         | 100     | Tribol GR 4020 PD | 150     |
| SHELL        | Spirax S1 ATF TASA | 80      | Retinax LX        | 140     |

### PowerMax cam unit SN5650-PMU-0065 – SN5650-PMU-0260

#### Application test in the cam of a cutting tool

Bronze with solid lubricant

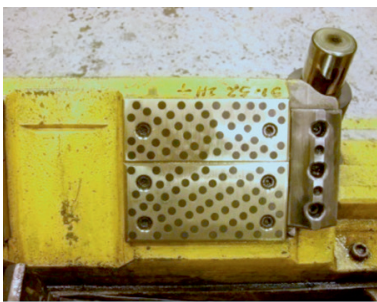

Test tool

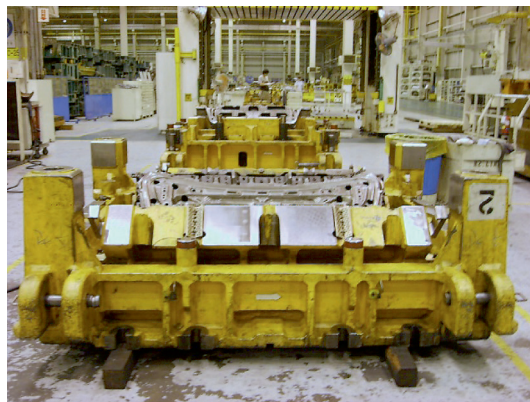

SNS Sinter metal

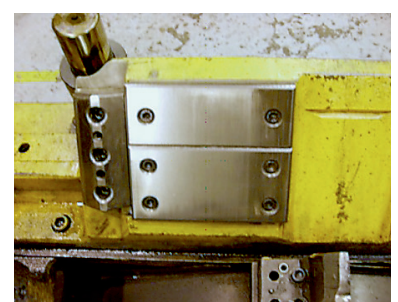

Counter bearing

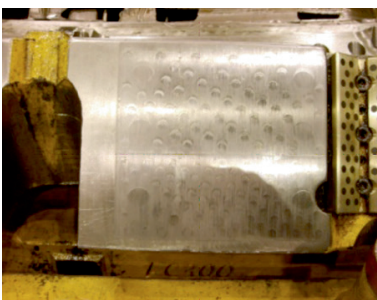

Counter bearing

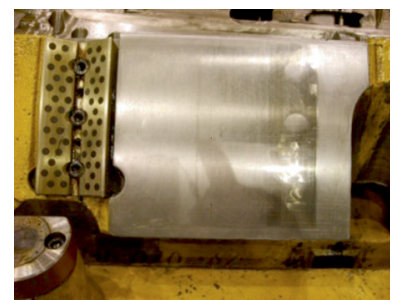

Already after 185.750 parts clear impressions of up to 0.02 mm in the counter bearing of the bronze guide rail.

### PowerMax cam unit SN5650-PMU-0065 – SN5650-PMU-0260

## 15. Appendix

### 15.1 Internet and CAD

The company **STRACK NORMA** has created an online presence for the PowerMax cam elements which is tailored to the requirements of the constructing engineers.

By using the link [www.strack.de](http://www.strack.de) you can reach the corresponding homepage.

### PowerMax cam unit SN5650-PMU-0065 – SN5650-PMU-0260

## 15.2 General description of gas springs

### GAS SPRINGS

The gas springs are developed and produced based on the long experience in the nitrogen gas spring research and development.

We understand that the final quality of our product is the individual quality of all its parts, and we therefore painstakingly check each and every one of them.

All the components are subjected to visual and dimensional inspection prior to assembly.

100 % of the gas springs are subjected to dynamic and static gas-proof testing.

All **STRACK** gas springs, thanks to their design, admit maintenance in a quick and simple manner.

Most **STRACK** gas springs have a one-piece construction in all their components, thus eliminating risks of breakage due to material fatigue and therefore also eliminating possible leakage points.

All **STRACK** gas springs are supplied with a quality certificate.

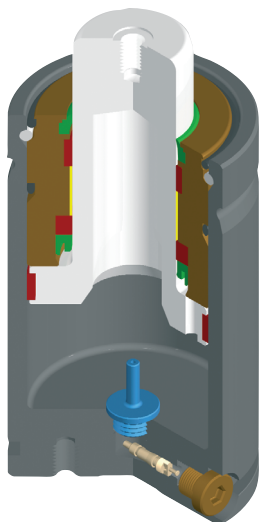

### COMPONENT CHARACTERISTICS

#### Body

Developed in one piece up to strokes of 125 mm. In higher strokes they have a tubular construction with a welded lid. As a difference with other brands, **STRACK** incorporates a threaded joint between the two elements that eliminates the possible fatigue factor in the weld bead.

#### Stem

Fatigue-resistant steels are employed, which have specific treatments that ensure a long useful life. **STRACK** offers the maximum quality MICROFINISH on the surface of all its stems, thus ensuring a longer service life by reducing friction and wear and tear in the seals..

#### Bushing

It incorporates a scraper, an element that avoids the entrance of filth. All bushings are designed avoiding a metal-to-metal contact, recurring to self-lubricating guiding elements. Reference to gastightness, specific seals are used, which have been painstakingly tested and which offer a high working yield even near their maximum limits of use.

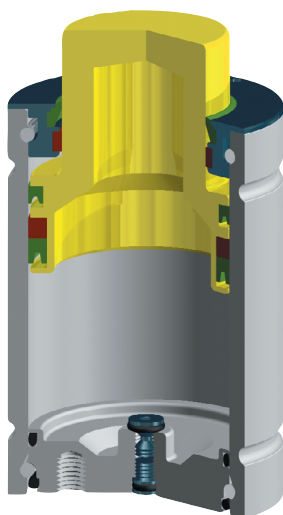



### PowerMax cam unit SN5650-PMU-0065 – SN5650-PMU-0260

#### 15.3 Maximal operating conditions for gas springs

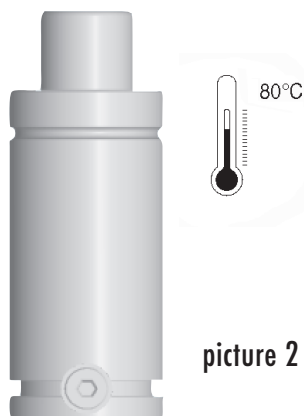
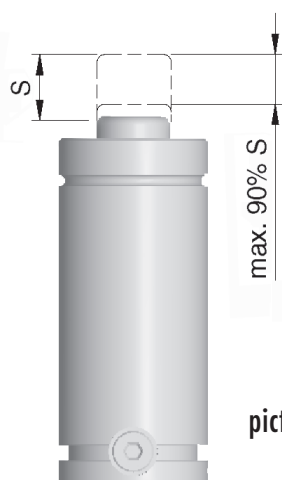
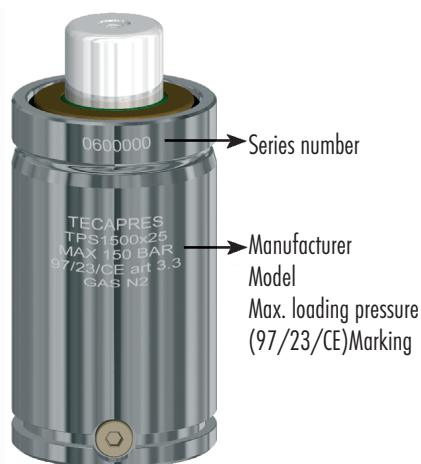

#### Identification

All **STRACK** gas springs are clearly identified by means of a consistent engraving on the body in accordance with the specification of the European norm (97/23/CE).

#### Working stroke

The working stroke is maintained invariable during use thanks to a mechanical stop. All **STRACK** gas springs can work using the whole of their nominal stroke (S) as all models have a stroke reserve. However, in order to reach an optimal service life, it is convenient to design with an optimal safety level. It is therefore recommended to foresee a 10 % stroke reserve. (picture 1)

#### Working temperature

Maximum working temperature is 80°C. Higher temperatures can damage the gastightness elements, and seriously affect the length of the gas spring service life. (picture 2)

#### Maximum filling pressure

You should never go over the maximum loading pressure for each gas spring, which is between 150 and 175 bar (at 20°C) depending on each model. Maximum loading pressure is detailed in each model's technical specifications.

#### Maximum working speed

Maximum lineal working stem speed is variable depending on the type of gas spring. Maximum working speeds are detailed in each model's technical specifications.

#### Maximum rate

The calculation of maximum rate per minute (N) is calculated following this formula:

$$N = \frac{K}{(2 \times S) + 50}$$

K = Calculation coefficient  
(values detailed in the technical specifications for each model)  
S = Working stroke



### PowerMax cam unit SN5650-PMU-0065 – SN5650-PMU-0260

## 15.4 Calculations gas springs

### Initial force

Gas spring initial force is calculated in relation with the working surface and loading force in accordance with the following formula:

$$F_i = A \times P$$

$F_i$  = Initial nominal force in daN  
 $A$  = Working area in cm<sup>2</sup> (as detailed in the specifications of each model)  
 $P$  = Loading pressure in Bar

### Variation of the initial force

Loading pressure may be modified to vary the initial force of a gas spring.

If we know the initial force, we can use the following formula:

$$P = P_i \times \frac{F}{F_i}$$

$P$  = Pressure wanted (Bar),  $P_i$  = Gas spring nominal loading pressure (Bar)  
 $F$  = Required initial force (daN),  $F_i$  = Gas spring nominal initial force (daN)

### Variation of forces depending on the temperature

Gas temperature affects the pressure of gas springs and therefore also their force. The forces specified in the catalogue correspond to loading pressures at a temperature of 20°C. In the temperature/pressure graph it is possible to see how nitrogen pressure varies according to the temperature.

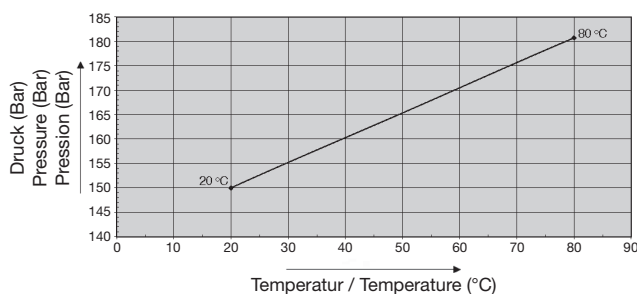

### Technical advice

With the purpose of helping our customers we have a technical advice service. By means of this service, you will receive advice from specialised technicians, and all your queries will be answered. We will help you choose the most adequate product depending on the type of work you wish to carry out.

### Guarantee and duration

The guarantee that STRACK offers in gas springs is for one year as from the date of acquisition, or the equivalent to a stem lineal displacement of 100,000 metres in gas springs with strokes equal to or over 25 mm. whereas in gas springs with shorter strokes the guarantee is of 2,000,000 cycles.

The guarantee (which covers parts and labour costs) is applicable if and when the following conditions are fulfilled:

1. The gas springs does not present defects due to dents (blows, scratches, welding detachments, rust and so on..).
2. Their application and use has been strictly within the limits of the technical conditions specified, and of the various applicable recommendations.
3. The gas spring has not been manipulated (opening the gas spring cancels the guarantee).

### PowerMax cam unit SN5650-PMU-0065 – SN5650-PMU-0260

#### 15.5 Mounting instructions gas springs

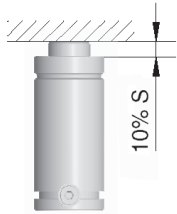

A 10 % nominal stroke reserve should be foreseen to prevent irreparable damage in the gas springs and serious safety hazards.

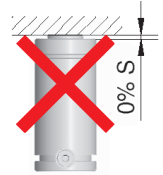

If possible fix the gas spring on the tool using the attachment holes at the bottom of the body or assembly accessories. Do not use threaded hole on the stem to fix the gas spring onto the tool.



Do not install the gas spring onto the tool in such a way it makes a free stem ejection possible. The installation of a compressed gas spring is dangerous due to serious safety risks.

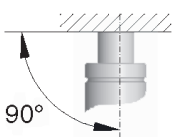
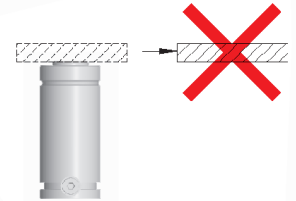

The gas spring is to work completely perpendicularly to the contact surface. Lateral forces reduce the gas spring's service life.

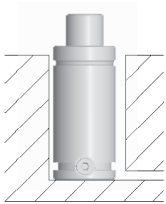

Protect the gas spring from direct contact with liquid pollution: lubricants, cleaners and so on..

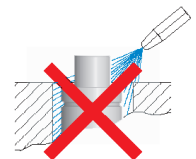

Protect the gas spring against mechanical damage or blows, especially the stem. Any imperfection may bring about a loss of pressure.

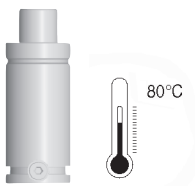

Service temperature should not exceed 80°C. Higher temperatures will affect the seals, reducing the gas spring's service life.



Do not exceed maximum filling pressures established for each Gas spring. Higher pressures will reduce both the gas spring service life and endanger its use.

## PowerMax cam unit SN5650-PMU-0065 – SN5650-PMU-0260

### 15.6 Filling pressure list gas springs

| Gasdruckfedern<br>Gas springs<br>Ressorts à gaz  | Fülldruck in bar / Filling pressure in bar / Pression de remplissage en bar |            |   |     |     |     |      |      |      |      |      |      |      |      |      |      |      | F max.<br>[daN] | P max.<br>[bar] |     |
|--|---|------------|---|-----|-----|-----|------|------|------|------|------|------|------|------|------|------|------|-----------------|-----------------|-----|
|  | Nenndruck<br>Nominal pressure / Pression nominale                           |            | Nennkraft<br>Nominal force / Force nominale |     |     |     |      |      |      |      |      |      |      |      |      |      |      |                 |                 |     |
|  | P<br>[bar]  | F<br>[daN] | A   | 30  | 40  | 50  | 60   | 70   | 80   | 90   | 100  | 110  | 120  | 130  | 140  | 150  | 160  |                 |                 | 170 |
| Zylinderkraft in daN bei Fülldruck in bar<br>Cylinder force in daN at filling pressure in bar<br>Force du cylindre en daN à pression de remplissage en bar |   |            |   |     |     |     |      |      |      |      |      |      |      |      |      |      |      |                 |                 |     |
| SN2800-42  | 150   | 42         | 0,28  | 8   | 11  | 14  | 17   | 20   | 22   | 25   | 28   | 31   | 34   | 36   | 39   | 42   |      |                 | 42              | 150 |
| SN2800-50  | 175   | 50         | 0,28  | 8   | 11  | 14  | 17   | 20   | 22   | 25   | 28   | 31   | 34   | 36   | 39   | 42   | 45   | 48              | 49              | 175 |
| SN2800-100   | 175   | 90         | 0,50  | 15  | 20  | 25  | 30   | 35   | 40   | 45   | 50   | 55   | 60   | 65   | 70   | 75   | 80   | 85              | 88              | 175 |
| SN2800-200   | 175   | 200        | 1,13  | 34  | 45  | 57  | 68   | 79   | 90   | 102  | 113  | 124  | 136  | 147  | 158  | 170  | 181  | 192             | 198             | 175 |
| SN2803-90  | 175   | 90         | 0,50  | 15  | 20  | 25  | 30   | 35   | 40   | 45   | 50   | 55   | 60   | 65   | 70   | 75   | 80   | 85              | 88              | 175 |
| SN2803-200   | 175   | 200        | 1,13  | 34  | 45  | 57  | 68   | 79   | 90   | 102  | 113  | 124  | 136  | 147  | 158  | 170  | 181  | 192             | 198             | 175 |
| SN2805-90  | 175   | 90         | 0,50  | 15  | 20  | 25  | 30   | 35   | 40   | 45   | 50   | 55   | 60   | 65   | 70   | 75   | 80   | 85              | 88              | 175 |
| SN2805-25-200  | 175   | 200        | 1,13  | 34  | 45  | 57  | 68   | 79   | 90   | 102  | 113  | 124  | 136  | 147  | 158  | 170  | 181  | 192             | 198             | 175 |
| SN2805-300   | 150   | 300        | 2,01  | 60  | 80  | 101 | 121  | 141  | 161  | 181  | 201  | 221  | 241  | 261  | 281  | 302  |      |                 | 312             | 155 |
| SN2805-450   | 175   | 450        | 2,54  | 76  | 102 | 127 | 152  | 178  | 203  | 229  | 254  | 279  | 305  | 330  | 356  | 381  | 406  | 432             | 445             | 175 |
| SN2807-500   | 190   | 500        | 2,54  | 76  | 102 | 127 | 152  | 178  | 203  | 229  | 254  | 279  | 305  | 330  | 356  | 381  | 406  | 432             | 508             | 200 |
| SN2807-750   | 190   | 750        | 3,80  | 114 | 152 | 190 | 228  | 266  | 304  | 342  | 380  | 418  | 456  | 494  | 532  | 570  | 608  | 646             | 760             | 200 |
| SN2807-920   | 150   | 920        | 6,16  | 185 | 246 | 308 | 370  | 431  | 493  | 554  | 616  | 678  | 739  | 801  | 862  | 924  |      |                 | 924             | 150 |
| SN2807-1200  | 150   | 1200       | 8,04  | 241 | 322 | 402 | 482  | 563  | 643  | 724  | 804  | 884  | 965  | 1045 | 1126 | 1206 |      |                 | 1206            | 150 |
| SN2807-2100  | 150   | 2100       | 13,85                                       | 416 | 554 | 693 | 831  | 970  | 1108 | 1247 | 1385 | 1524 | 1662 | 1801 | 1939 | 2078 |      |                 | 2078            | 150 |
| SN2807-3000  | 150   | 3000       | 19,63                                       | 589 | 785 | 982 | 1178 | 1374 | 1570 | 1767 | 1963 | 2159 | 2356 | 2552 | 2748 | 2945 |      |                 | 2945            | 150 |
| SN2808-90  | 175   | 90         | 0,50  | 15  | 20  | 25  | 30   | 35   | 40   | 45   | 50   | 55   | 60   | 65   | 70   | 75   | 80   | 85              | 88              | 175 |
| SN2808-V-170   | 175   | 170        | 0,95  | 29  | 38  | 48  | 57   | 67   | 76   | 86   | 95   | 105  | 114  | 124  | 133  | 143  | 152  | 162             | 166             | 175 |
| SN2808-275   | 175   | 275        | 1,54  | 46  | 62  | 77  | 92   | 108  | 123  | 139  | 154  | 169  | 185  | 200  | 216  | 231  | 246  | 262             | 270             | 175 |
| SN2808-H-275   | 175   | 275        | 1,54  | 46  | 62  | 77  | 92   | 108  | 123  | 139  | 154  | 169  | 185  | 200  | 216  | 231  | 246  | 262             | 270             | 175 |
| SN2808-R-275   | 175   | 275        | 1,54  | 46  | 62  | 77  | 92   | 108  | 123  | 139  | 154  | 169  | 185  | 200  | 216  | 231  | 246  | 262             | 270             | 175 |
| SN2808-V-350   | 175   | 350        | 2,01  | 60  | 80  | 101 | 121  | 141  | 161  | 181  | 201  | 221  | 241  | 261  | 281  | 302  | 322  | 342             | 352             | 175 |
| SN2808-VS-350  | 175   | 350        | 2,01  | 60  | 80  | 101 | 121  | 141  | 161  | 181  | 201  | 221  | 241  | 261  | 281  | 302  | 322  | 342             | 352             | 175 |
| SN2808-C-350   | 175   | 350        | 2,01  | 60  | 80  | 101 | 121  | 141  | 161  | 181  | 201  | 221  | 241  | 261  | 281  | 302  | 322  | 342             | 352             | 175 |
| SN2808-450   | 175   | 450        | 2,54  | 76  | 102 | 127 | 152  | 178  | 203  | 229  | 254  | 279  | 305  | 330  | 356  | 381  | 406  | 432             | 445             | 175 |
| SN2808-H-450   | 175   | 450        | 2,54  | 76  | 102 | 127 | 152  | 178  | 203  | 229  | 254  | 279  | 305  | 330  | 356  | 381  | 406  | 432             | 457             | 175 |
| SN2808-R-450   | 175   | 450        | 2,54  | 76  | 102 | 127 | 152  | 178  | 203  | 229  | 254  | 279  | 305  | 330  | 356  | 381  | 406  | 432             | 457             | 175 |
| SN2808-V-470   | 150   | 470        | 3,14  | 94  | 126 | 157 | 188  | 220  | 251  | 283  | 314  | 345  | 377  | 408  | 440  | 471  |      |                 | 471             | 150 |
| SN2808-VS-470  | 150   | 470        | 3,14  | 94  | 126 | 157 | 188  | 220  | 251  | 283  | 314  | 345  | 377  | 408  | 440  | 471  |      |                 | 471             | 150 |
| SN2808-660   | 175   | 660        | 3,80  | 114 | 152 | 190 | 228  | 266  | 304  | 342  | 380  | 418  | 456  | 494  | 532  | 570  | 608  | 646             | 665             | 175 |
| SN2808-H-660   | 175   | 660        | 3,80  | 114 | 152 | 190 | 228  | 266  | 304  | 342  | 380  | 418  | 456  | 494  | 532  | 570  | 608  | 646             | 684             | 175 |
| SN2808-R-660   | 175   | 660        | 3,80  | 114 | 152 | 190 | 228  | 266  | 304  | 342  | 380  | 418  | 456  | 494  | 532  | 570  | 608  | 646             | 684             | 175 |
| SN2808-800   | 150   | 800        | 4,90  | 147 | 196 | 245 | 294  | 343  | 392  | 441  | 490  | 539  | 588  | 637  | 686  | 735  |      |                 | 735             | 150 |
| SN2808-V-800   | 150   | 740        | 4,91  | 147 | 196 | 246 | 295  | 344  | 393  | 442  | 491  | 540  | 589  | 638  | 687  | 737  |      |                 | 737             | 150 |
| SN2808-920   | 150   | 920        | 6,16  | 185 | 246 | 308 | 370  | 431  | 493  | 554  | 616  | 678  | 739  | 801  | 862  | 924  |      |                 | 924             | 150 |
| SN2808-VS-920  | 150   | 920        | 6,16  | 185 | 246 | 308 | 370  | 431  | 493  | 554  | 616  | 678  | 739  | 801  | 862  | 924  |      |                 | 924             | 150 |
| SN2808-C-1100  | 160   | 1100       | 7,07  | 212 | 283 | 354 | 424  | 495  | 566  | 636  | 707  | 778  | 848  | 919  | 990  | 1061 | 1131 |                 | 1131            | 160 |

Näherungswerte, Abweichungen möglich / Approximate values, tolerances possible / Valeurs approchées, tolérances possibles

## PowerMax cam unit SN5650-PMU-0065 – SN5650-PMU-0260

### Filling pressure list gas springs

| Gasdruckfedern<br>Gas springs<br>Ressorts à gaz  | Fülldruck in bar / Filling pressure in bar / Pression de remplissage en bar |            |        |   |      |      |      |      |       |       |       |       |       |       |       |       |      | F max.<br>[daN] | P max.<br>[bar] |     |
|--|---|------------|--------|---|------|------|------|------|-------|-------|-------|-------|-------|-------|-------|-------|------|-----------------|-----------------|-----|
|  | Nenndruck<br>Nominal pressure / Pression nominale                           |            |        | Nennkraft<br>Nominal force / Force nominale |      |      |      |      |       |       |       |       |       |       |       |       |      |                 |                 |     |
|  | P<br>[bar]  | F<br>[daN] | A      | 30  | 40   | 50   | 60   | 70   | 80    | 90    | 100   | 110   | 120   | 130   | 140   | 150   | 160  |                 |                 | 170 |
| Zylinderkraft in daN bei Fülldruck in bar<br>Cylinder force in daN at filling pressure in bar<br>Force du cylindre en daN à pression de remplissage en bar |   |            |        |   |      |      |      |      |       |       |       |       |       |       |       |       |      |                 |                 |     |
| SN2808-V-1100  | 160   | 1100       | 7,07   | 212   | 283  | 354  | 424  | 495  | 566   | 636   | 707   | 778   | 848   | 919   | 990   | 1061  | 1131 |                 | 1131            | 160 |
| SN2808-C-1500  | 150   | 1500       | 10,18  | 305   | 407  | 509  | 611  | 713  | 814   | 916   | 1018  | 1120  | 1222  | 1323  | 1425  | 1527  |      |                 | 1527            | 150 |
| SN2808-V-1500  | 150   | 1500       | 10,18  | 305   | 407  | 509  | 611  | 713  | 814   | 916   | 1018  | 1120  | 1222  | 1323  | 1425  | 1527  |      |                 | 1527            | 150 |
| SN2808-1900  | 150   | 1900       | 12,57  | 377   | 503  | 629  | 754  | 880  | 1006  | 1131  | 1257  | 1383  | 1508  | 1634  | 1760  | 1886  |      |                 | 1886            | 150 |
| SN2808-2400  | 150   | 2400       | 15,90  | 477   | 636  | 795  | 954  | 1113 | 1272  | 1431  | 1590  | 1749  | 1908  | 2067  | 2226  | 2385  |      |                 | 2385            | 150 |
| SN2808-4250  | 150   | 4250       | 28,27  | 848   | 1131 | 1414 | 1696 | 1979 | 2262  | 2544  | 2827  | 3110  | 3392  | 3675  | 3958  | 4241  |      |                 | 4241            | 150 |
| SN2808-6600  | 150   | 6600       | 44,18  | 1325  | 1767 | 2209 | 2651 | 3093 | 3534  | 3976  | 4418  | 4860  | 5302  | 5743  | 6185  | 6627  |      |                 | 6627            | 150 |
| SN2808-V-6600  | 150   | 6600       | 44,18  | 1325  | 1767 | 2209 | 2651 | 3093 | 3534  | 3976  | 4418  | 4860  | 5302  | 5743  | 6185  | 6627  |      |                 | 6627            | 150 |
| SN2808-9500  | 150   | 9500       | 63,62  | 1909  | 2545 | 3181 | 3817 | 4453 | 5090  | 5726  | 6362  | 6998  | 7634  | 8271  | 8907  | 9543  |      |                 | 9543            | 150 |
| SN2808-20000   | 150   | 20000      | 132,73 | 3982  | 5309 | 6637 | 7964 | 9291 | 10618 | 11946 | 13273 | 14600 | 15928 | 17255 | 18582 | 19910 |      |                 | 19910           | 150 |
| SN2809-200   | 175   | 200        | 1,13   | 34  | 45   | 57   | 68   | 79   | 90    | 102   | 113   | 124   | 136   | 147   | 158   | 170   | 181  | 192             | 198             | 175 |
| SN2809-R-200   | 175   | 200        | 1,13   | 34  | 45   | 57   | 68   | 79   | 90    | 102   | 113   | 124   | 136   | 147   | 158   | 170   | 181  | 192             | 198             | 175 |
| SN2809-400   | 155   | 400        | 2,54   | 76  | 102  | 127  | 152  | 178  | 203   | 229   | 254   | 279   | 305   | 330   | 356   | 381   |      |                 | 394             | 155 |
| SN2809-600   | 155   | 600        | 3,80   | 114   | 152  | 190  | 228  | 266  | 304   | 342   | 380   | 418   | 456   | 494   | 532   | 570   |      |                 | 589             | 155 |
| SN2809-750   | 150   | 750        | 4,90   | 147   | 196  | 245  | 294  | 343  | 392   | 441   | 490   | 539   | 588   | 637   | 686   | 735   |      |                 | 735             | 150 |
| SN2809-1000  | 142   | 1000       | 7,07   | 212   | 283  | 354  | 424  | 495  | 566   | 636   | 707   | 778   | 848   | 919   | 990   | 1061  |      |                 | 1061            | 150 |
| SN2809-1500  | 148   | 1500       | 10,17  | 305   | 407  | 509  | 610  | 712  | 814   | 915   | 1017  | 1119  | 1220  | 1322  | 1424  | 1526  |      |                 | 1526            | 150 |
| SN2809-3000  | 150   | 3000       | 19,63  | 589   | 785  | 982  | 1178 | 1374 | 1570  | 1767  | 1963  | 2159  | 2356  | 2552  | 2748  | 2945  |      |                 | 2945            | 150 |
| SN2820-200   | 175   | 200        | 1,13   | 34  | 45   | 57   | 68   | 79   | 90    | 102   | 113   | 124   | 136   | 147   | 158   | 170   | 181  | 192             | 198             | 175 |
| SN2820-250   | 142   | 250        | 1,77   | 53  | 71   | 89   | 106  | 124  | 142   | 159   | 177   | 195   | 212   | 230   | 248   | 266   |      |                 | 266             | 150 |
| SN2820-P-300   | 150   | 300        | 2,01   | 60  | 80   | 101  | 121  | 141  | 161   | 181   | 201   | 221   | 241   | 261   | 281   | 302   | 322  | 342             | 302             | 150 |
| SN2820-500   | 150   | 470        | 3,14   | 94  | 126  | 157  | 188  | 220  | 251   | 283   | 314   | 345   | 377   | 408   | 440   | 471   |      |                 | 471             | 150 |
| SN2820-P-500   | 150   | 500        | 3,14   | 94  | 126  | 157  | 188  | 220  | 251   | 283   | 314   | 345   | 377   | 408   | 440   | 471   |      |                 | 471             | 150 |
| SN2820-750   | 150   | 740        | 4,90   | 147   | 196  | 245  | 294  | 343  | 392   | 441   | 490   | 539   | 588   | 637   | 686   | 735   |      |                 | 735             | 150 |
| SN2820-C-750   | 150   | 740        | 4,91   | 147   | 196  | 246  | 295  | 344  | 393   | 442   | 491   | 540   | 589   | 638   | 687   | 737   |      |                 | 737             | 150 |
| SN2820-P-750   | 150   | 740        | 3,14   | 94  | 126  | 157  | 188  | 220  | 251   | 283   | 314   | 345   | 377   | 408   | 440   | 471   |      |                 | 471             | 150 |
| SN2820-P-1000  | 142   | 1000       | 7,07   | 212   | 283  | 354  | 424  | 495  | 566   | 636   | 707   | 778   | 848   | 919   | 990   | 1061  |      |                 | 1061            | 150 |
| SN2820-1500  | 148   | 1500       | 10,17  | 305   | 407  | 509  | 610  | 712  | 814   | 915   | 1017  | 1119  | 1220  | 1322  | 1424  | 1526  |      |                 | 1526            | 150 |
| SN2820-C-1500  | 148   | 1500       | 10,18  | 305   | 407  | 509  | 611  | 713  | 814   | 916   | 1018  | 1120  | 1222  | 1323  | 1425  | 1527  |      |                 | 1527            | 150 |
| SN2820-P-2400  | 150   | 2400       | 15,90  | 477   | 636  | 795  | 954  | 1113 | 1272  | 1431  | 1590  | 1749  | 1908  | 2067  | 2226  | 2385  |      |                 | 2385            | 150 |
| SN2820-3000  | 150   | 3000       | 19,63  | 589   | 785  | 982  | 1178 | 1374 | 1570  | 1767  | 1963  | 2159  | 2356  | 2552  | 2748  | 2945  |      |                 | 2945            | 150 |
| SN2820-C-3000  | 150   | 3000       | 19,63  | 589   | 785  | 982  | 1178 | 1374 | 1570  | 1767  | 1963  | 2159  | 2356  | 2552  | 2748  | 2945  |      |                 | 2945            | 150 |
| SN2820-P-4200  | 150   | 4200       | 28,27  | 848   | 1131 | 1414 | 1696 | 1979 | 2262  | 2544  | 2827  | 3110  | 3392  | 3675  | 3958  | 4241  |      |                 | 4241            | 150 |
| SN2820-5000  | 150   | 5000       | 31,18  | 935   | 1247 | 1559 | 1871 | 2183 | 2494  | 2806  | 3118  | 3430  | 3742  | 4053  | 4365  | 4677  |      |                 | 4677            | 150 |
| SN2820-C-5000  | 150   | 5000       | 33,18  | 995   | 1327 | 1659 | 1991 | 2323 | 2654  | 2986  | 3318  | 3650  | 3982  | 4313  | 4645  | 4977  |      |                 | 4977            | 150 |
| SN2820-P-6600  | 147   | 6600       | 44,18  | 1325  | 1767 | 2209 | 2651 | 3093 | 3534  | 3976  | 4418  | 4860  | 5302  | 5743  | 6185  | 6627  |      |                 | 6627            | 150 |
| SN2820-7500  | 150   | 7500       | 50,26  | 1508  | 2010 | 2513 | 3016 | 3518 | 4021  | 4523  | 5026  | 5529  | 6031  | 6534  | 7036  | 7539  |      |                 | 7539            | 150 |

Näherungswerte, Abweichungen möglich / Approximate values, tolerances possible / Valeurs approchées, tolérances possibles

## PowerMax cam unit SN5650-PMU-0065 – SN5650-PMU-0260

### Filling pressure list gas springs

| Gasdruckfedern<br>Gas springs<br>Ressorts à gaz  | Fülldruck in bar / Filling pressure in bar / Pression de remplissage en bar |            |  |      |      |      |      |      |      |       |       |       |       |       |       |       |      | F max.<br>[daN] | P max.<br>[bar] |     |
|--|---|------------|--|------|------|------|------|------|------|-------|-------|-------|-------|-------|-------|-------|------|-----------------|-----------------|-----|
|  | Nominaldruck<br>Nominal pressure / Pression nominale                        |            | Nominalkraft<br>Nominal force / Force nominale |      |      |      |      |      |      |       |       |       |       |       |       |       |      |                 |                 |     |
|  | P<br>[bar]  | F<br>[daN] | A  | 30   | 40   | 50   | 60   | 70   | 80   | 90    | 100   | 110   | 120   | 130   | 140   | 150   | 160  |                 |                 | 170 |
| Zylinderkraft in daN bei Fülldruck in bar<br>Cylinder force in daN at filling pressure in bar<br>Force du cylindre en daN à pression de remplissage en bar |   |            |  |      |      |      |      |      |      |       |       |       |       |       |       |       |      |                 |                 |     |
| SN2820-C-7500  | 150   | 7500       | 50,27  | 1508 | 2011 | 2514 | 3016 | 3519 | 4022 | 4524  | 5027  | 5530  | 6032  | 6535  | 7038  | 7541  |      |                 | 7541            | 150 |
| SN2820-P-9500  | 150   | 9500       | 63,62  | 1909 | 2545 | 3181 | 3817 | 4453 | 5090 | 5726  | 6362  | 6998  | 7634  | 8271  | 8907  | 9543  |      |                 | 9543            | 150 |
| SN2820-A-10000   | 141   | 10000      | 70,88  | 2126 | 2835 | 3544 | 4253 | 4962 | 5670 | 6379  | 7088  | 7797  | 8506  | 9214  | 9923  | 10632 |      |                 | 10632           | 150 |
| SN2820-C-10000   | 141   | 10000      | 70,88  | 2126 | 2835 | 3544 | 4253 | 4962 | 5670 | 6379  | 7088  | 7797  | 8506  | 9214  | 9923  | 10632 |      |                 | 10632           | 150 |
| SN2825-750   | 150   | 750        | 4,91   | 147  | 196  | 246  | 295  | 344  | 393  | 442   | 491   | 540   | 589   | 638   | 687   | 736   |      |                 | 737             | 150 |
| SN2825-1250  | 175   | 1250       | 7,07   | 212  | 283  | 354  | 424  | 495  | 566  | 636   | 707   | 778   | 848   | 919   | 990   | 1061  | 1131 | 1202            | 1237            | 175 |
| SN2825-1500  | 148   | 1500       | 10,18  | 305  | 407  | 509  | 611  | 713  | 814  | 916   | 1018  | 1120  | 1222  | 1323  | 1425  | 1527  |      |                 | 1527            | 150 |
| SN2825-1800  | 175   | 1800       | 10,18  | 305  | 407  | 509  | 611  | 713  | 814  | 916   | 1018  | 1120  | 1222  | 1323  | 1425  | 1527  | 1629 | 1731            | 1782            | 175 |
| SN2825-3000  | 150   | 3000       | 19,63  | 589  | 785  | 982  | 1178 | 1374 | 1570 | 1767  | 1963  | 2159  | 2356  | 2552  | 2748  | 2945  |      |                 | 2945            | 150 |
| SN2825-5000  | 150   | 5000       | 33,18  | 995  | 1327 | 1659 | 1991 | 2323 | 2654 | 2986  | 3318  | 3650  | 3982  | 4313  | 4645  | 4977  |      |                 | 4977            | 150 |
| SN2830-350   | 138   | 350        | 2,54   | 76   | 102  | 127  | 152  | 178  | 203  | 229   | 254   | 279   | 305   | 330   | 356   | 381   |      |                 | 381             | 150 |
| SN2830-500   | 132   | 500        | 3,80   | 114  | 152  | 190  | 228  | 266  | 304  | 342   | 380   | 418   | 456   | 494   | 532   | 570   |      |                 | 570             | 150 |
| SN2830-1000  | 142   | 1000       | 7,06   | 212  | 282  | 353  | 424  | 494  | 565  | 635   | 706   | 777   | 847   | 918   | 988   | 1059  |      |                 | 1059            | 150 |
| SN2830-1500  | 148   | 1500       | 10,17  | 305  | 407  | 509  | 610  | 712  | 814  | 915   | 1017  | 1119  | 1220  | 1322  | 1424  | 1526  |      |                 | 1526            | 150 |
| SN2900-420   | 133   | 420        | 3,14   | 94   | 126  | 157  | 188  | 220  | 251  | 283   | 314   | 345   | 377   | 408   | 440   | 471   |      |                 | 471             | 150 |
| SN2900-750   | 150   | 750        | 4,90   | 147  | 196  | 245  | 294  | 343  | 392  | 441   | 490   | 539   | 588   | 637   | 686   | 735   |      |                 | 735             | 150 |
| SN2900-7000  | 139   | 7000       | 50,27  | 1508 | 2011 | 2514 | 3016 | 3519 | 4022 | 4524  | 5027  | 5530  | 6032  | 6535  | 7038  | 7541  |      |                 | 7541            | 150 |
| SN2900-7500  | 150   | 7500       | 50,26  | 1508 | 2010 | 2513 | 3016 | 3518 | 4021 | 4523  | 5026  | 5529  | 6031  | 6534  | 7036  | 7539  |      |                 | 7539            | 150 |
| SN2900-11800   | 150   | 11800      | 78,54  | 2356 | 3142 | 3927 | 4712 | 5498 | 6283 | 7069  | 7854  | 8639  | 9425  | 10210 | 10996 | 11781 |      |                 | 11781           | 150 |
| SN2900-18300   | 150   | 18300      | 122,72   | 3682 | 4909 | 6136 | 7363 | 8590 | 9818 | 11045 | 12272 | 13499 | 14726 | 15954 | 17181 | 18408 |      |                 | 18408           | 150 |
| SN2901-7500  | 150   | 7500       | 50,26  | 1508 | 2010 | 2513 | 3016 | 3518 | 4021 | 4523  | 5026  | 5529  | 6031  | 6534  | 7036  | 7539  |      |                 | 7539            | 150 |
| SN2901-11800   | 150   | 11800      | 78,54  | 2356 | 3142 | 3927 | 4712 | 5498 | 6283 | 7069  | 7854  | 8639  | 9425  | 10210 | 10996 | 11781 |      |                 | 11781           | 150 |
| SN2901-18300   | 150   | 18300      | 122,72   | 3682 | 4909 | 6136 | 7363 | 8590 | 9818 | 11045 | 12272 | 13499 | 14726 | 15954 | 17181 | 18408 |      |                 | 18408           | 150 |
| SN2902-1000  | 150   | 1000       | 7,07   | 212  | 283  | 354  | 424  | 495  | 566  | 636   | 707   | 778   | 848   | 919   | 990   | 1061  |      |                 | 1061            | 150 |
| SN2902-1800  | 142   | 1800       | 12,57  | 377  | 503  | 629  | 754  | 880  | 1006 | 1131  | 1257  | 1383  | 1508  | 1634  | 1760  | 1886  |      |                 | 1886            | 150 |
| SN2902-2000  | 155   | 2000       | 12,57  | 377  | 503  | 629  | 754  | 880  | 1006 | 1131  | 1257  | 1383  | 1508  | 1634  | 1760  | 1886  |      |                 | 1948            | 155 |
| SN2902-3000  | 150   | 3000       | 19,63  | 589  | 785  | 982  | 1178 | 1374 | 1570 | 1767  | 1963  | 2159  | 2356  | 2552  | 2748  | 2945  |      |                 | 2945            | 150 |
| SN2902-4700  | 150   | 4700       | 31,17  | 935  | 1247 | 1559 | 1870 | 2182 | 2494 | 2805  | 3117  | 3429  | 3740  | 4052  | 4364  | 4676  |      |                 | 4676            | 150 |
| SN2910-M16   | 175   | 50         | 0,28   | 8    | 11   | 14   | 17   | 20   | 22   | 25    | 28    | 31    | 34    | 36    | 39    | 42    | 45   | 48              | 49              | 175 |
| SN2910-M24   | 175   | 140        | 0,78   | 23   | 31   | 39   | 47   | 55   | 62   | 70    | 78    | 86    | 94    | 101   | 109   | 117   | 125  | 133             | 137             | 175 |
| SN2910-M28   | 175   | 200        | 1,13   | 34   | 45   | 57   | 68   | 79   | 90   | 102   | 113   | 124   | 136   | 147   | 158   | 170   | 181  | 192             | 198             | 175 |
| SN2910-M38x1.5   | 142   | 250        | 1,77   | 53   | 71   | 89   | 106  | 124  | 142  | 159   | 177   | 195   | 212   | 230   | 248   | 266   |      |                 | 266             | 150 |
| SN2910-M45   | 150   | 750        | 4,90   | 147  | 196  | 245  | 294  | 343  | 392  | 441   | 490   | 539   | 588   | 637   | 686   | 735   |      |                 | 735             | 150 |
| SN2910-M50   | 142   | 1000       | 7,06   | 212  | 282  | 353  | 424  | 494  | 565  | 635   | 706   | 777   | 847   | 918   | 988   | 1059  |      |                 | 1059            | 150 |

**PowerMax cam unit SN5650-PMO-0065 – SN5650-PMO-0260**

### PowerMax cam unit SN5650-PMU-0065 – SN5650-PMU-0260

#### 16. Exploded view and item list

On the following pages you will find an exploded view and an item list (exemplary) like it can be downloaded on the internet side of the PowerMax cam ([www.strack.de](http://www.strack.de))

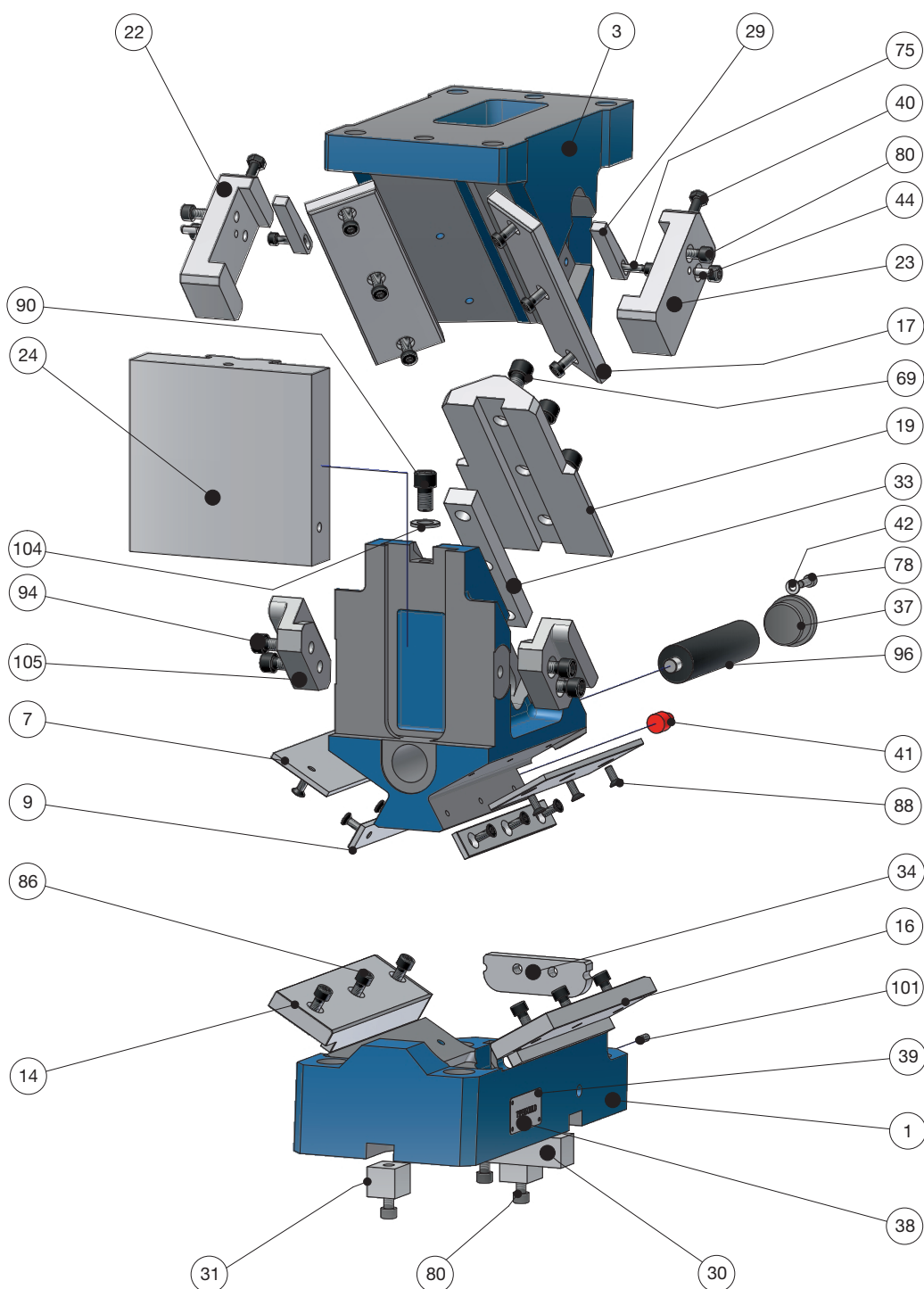



### PowerMax cam unit SN5650-PMU-0065 – SN5650-PMU-0260

| Stückliste zu /<br>Partlist to: SN5650-PMU-0165-20-B-N *** SN5650-PMU-0165-20-M-N *** SN5650-PMU-0165-20-P-N |               |  |                    |        |         |
|--|---------------|--|--------------------|--------|---------|
| Pos  | Stck<br>Piece | Bezeichnung / partname   | Art.Nr. / Art.-No. |        |         |
|  |               |  | BASIC              | MEDIUM | PREMIUM |
|  |               | Set-Nr. / Set-No.:   | 222126             | 222128 | 222130  |
| 1  | 1             | SN5650-PMU-SAF-0165-20-N-V01   | 225101             | 225101 | 225101  |
| 2  | 1             | SN5650-PMU-SKF-0165-20-B-V01<br>SN5650-PMU-SKF-0165-20-M-V01<br>SN5650-PMU-SKF-0165-20-P-V01 | 225246             | 225252 | 225258  |
| 3  | 1             | SN5650-PMU-TF-0165-20-V01  | 225408             | 225408 | 225408  |
| 7  | 2             | SN5650-PMU-BS-T4-V01   | 227023             | 227023 | 227023  |
| 9  | 2             | SN5650-PMU-BSS-T2-V01  | 227018             | 227018 | 227018  |
| 14   | 1             | SN5650-PMU-GSAL-B-T4-V01<br>SN5650-PMU-GSAL-P-T4-V01<br>SN5650-PMU-GSAL-P-T4-V01             | 227040             | 227045 | 227045  |
| 16   | 1             | SN5650-PMU-GSAR-B-T4-V01<br>SN5650-PMU-GSAR-P-T4-V01<br>SN5650-PMU-GSAR-P-T4-V01             | 227056             | 227061 | 227061  |
| 17   | 2             | SN5650-PMU-GST-B-T4-V01<br>SN5650-PMU-GST-P-T4-V01<br>SN5650-PMU-GST-P-T4-V01                | 227066             | 227076 | 227076  |
| 19   | 1             | SN5650-PMU-GTL-T4-V01  | 227082             | 227082 | 227082  |
| 22   | 1             | SN5650-PMU-ZWL-B-T4-V01<br>SN5650-PMU-ZWL-P-T4-V01<br>SN5650-PMU-ZWL-P-T4-V01                | 227136             | 227142 | 227142  |
| 23   | 1             | SN5650-PMU-ZWR-B-T4-V01<br>SN5650-PMU-ZWR-P-T4-V01<br>SN5650-PMU-ZWR-P-T4-V01                | 227148             | 227154 | 227154  |
| 24   | 1             | SN5650-PMU-AP-T4-V01   |                    |        | 227006  |
| 29   | 2             | SN5650-PMU-KEZ-T4-V01  |                    | 227096 | 227096  |
| 30   | 1             | SN5650-PMU-PS1-T4-V01  | 227102             | 227102 | 227102  |
| 31   | 2             | SN5650-PMU-PS2-T2-V01  | 227107             | 227107 | 227107  |
| 33   | 1             | SN5650-PMU-PST-V01   | 227111             | 227111 | 227111  |
| 34   | 1             | SN5650-PMU-SA-T4-V01   | 227115             | 227115 | 227115  |
| 37   | 1             | SN5650-PMU-VS-T3-V01   | 227131             | 227131 | 227131  |
| 38   | 1             | SN5650-PMU-TYPS-V01  | 227128             | 227128 | 227128  |
| 39   | 4             | SN5650-PMU-PN-4-3  | 227098             | 227098 | 227098  |
| 40   | 2             | SN5650-PMU-SKS-M8-16   | 227126             | 227126 | 227126  |
| 41   | 2             | SN1817-16-25   | 64791              | 64791  | 64791   |
| 42   | 1             | SN5650-PMU-SB-M6   | 227122             | 227122 | 227122  |
| 44   | 2             | SN1975-6-16  | 62508              | 62508  | 62508   |
| 69   | 3             | SN3450-M12-35  | 62733              | 62733  | 62733   |
| 75   | 2             | SN3450-M6-25   |                    | 62688  | 62688   |
| 78   | 1             | SN3450-M8-16   | 62698              | 62698  | 62698   |
| 80   | 7             | SN3450-M8-25   | 62700              | 62700  | 62700   |
| 86   | 12            | SN3540-M8-20   | 62607              | 62607  | 62607   |
| 88   | 12            | SN3550-M6-16   | 62642              | 62642  | 62642   |
| 90   | 1             | SN3450-M12-20  |                    |        | 62730   |
| 94   | 4             | SN3450-M10-20  | 62714              | 62714  | 62714   |
| 96   | 1             | SN2820-200-80-4  | 70274              | 70274  | 70274   |
| 101  | 2             | SN3600-M6-16   | 140836             | 140836 | 140836  |
| 104  | 1             | SN5650-PMU-SB-M12  |                    |        | 227121  |
| 105  | 2             | SN5650-PMU-EZS-T4-V01  | 227033             | 227033 | 227033  |

Partlist of examples

# STRACK®

## NORMALIEN

### STRACK NORMA GmbH & Co. KG

Königsberger Str. 11  
D-58511 Lüdenscheid  
Postfach 16 29  
D-58466 Lüdenscheid

**Tel** +49 2351 8701-0  
**Fax** +49 2351 8701-100  
**Mail** [info@strack.de](mailto:info@strack.de)  
**Web** [www.strack.de](http://www.strack.de)

