

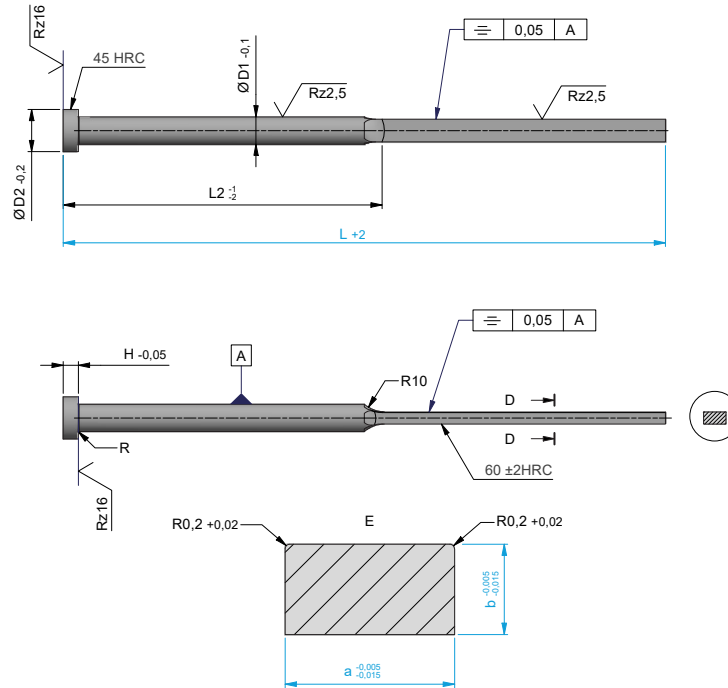

**Z85**

Flat ejector pin with chamfer radii, 2-fold



Mat.:  
1.2067  
Norm:  
DIN ISO 6893,  
Form FAH

a	b	L	L2	D1	D2	H	R	Order No.
1.8	0.8	100	50	2	4	2	0.2	Z85-1.8-0.8-100
1.8	0.8	125	60	2	4	2	0.2	Z85-1.8-0.8-125
1.8	0.8	160	80	2	4	2	0.2	Z85-1.8-0.8-160
1.8	0.8	200	100	2	4	2	0.2	Z85-1.8-0.8-200
1.8	0.8	250	125	2	4	2	0.2	Z85-1.8-0.8-250
1.8	0.8	315	160	2	4	2	0.2	Z85-1.8-0.8-315
2	2	100	50	3	6	3	0.3	Z85-2-2-100
2	2	125	60	3	6	3	0.3	Z85-2-2-125
2	2	160	80	3	6	3	0.3	Z85-2-2-160
2	2	200	100	3	6	3	0.3	Z85-2-2-200
2	2	250	125	3	6	3	0.3	Z85-2-2-250
2	2	315	160	3	6	3	0.3	Z85-2-2-315
2.3	0.8	100	50	2.5	5	2	0.3	Z85-2.3-0.8-100
2.3	0.8	125	60	2.5	5	2	0.3	Z85-2.3-0.8-125
2.3	0.8	160	80	2.5	5	2	0.3	Z85-2.3-0.8-160
2.3	0.8	200	100	2.5	5	2	0.3	Z85-2.3-0.8-200
2.8	0.5	80	40	3	6	3	0.3	Z85-2.8-0.5-80
2.8	0.5	100	50	3	6	3	0.3	Z85-2.8-0.5-100
2.8	0.5	125	60	3	6	3	0.3	Z85-2.8-0.5-125
2.8	0.5	160	80	3	6	3	0.3	Z85-2.8-0.5-160
2.8	0.6	80	40	3	6	3	0.3	Z85-2.8-0.6-80
2.8	0.6	100	50	3	6	3	0.3	Z85-2.8-0.6-100
2.8	0.6	125	60	3	6	3	0.3	Z85-2.8-0.6-125
2.8	0.6	160	80	3	6	3	0.3	Z85-2.8-0.6-160
2.8	0.6	200	100	3	6	3	0.3	Z85-2.8-0.6-200
2.8	0.7	125	60	3	6	3	0.3	Z85-2.8-0.7-125
2.8	0.7	160	80	3	6	3	0.3	Z85-2.8-0.7-160
2.8	0.7	200	100	3	6	3	0.3	Z85-2.8-0.7-200
2.8	0.7	250	125	3	6	3	0.3	Z85-2.8-0.7-250
2.8	0.8	80	40	3	6	3	0.3	Z85-2.8-0.8-80
2.8	0.8	100	50	3	6	3	0.3	Z85-2.8-0.8-100

a	b	L	L2	D1	D2	H	R	Order No.
2.8	0.8	125	60	3	6	3	0.3	Z85-2.8-0.8-125
2.8	0.8	160	80	3	6	3	0.3	Z85-2.8-0.8-160
2.8	0.8	200	100	3	6	3	0.3	Z85-2.8-0.8-200
2.8	0.8	250	125	3	6	3	0.3	Z85-2.8-0.8-250
2.8	0.8	315	160	3	6	3	0.3	Z85-2.8-0.8-315
2.8	1	100	50	3	6	3	0.3	Z85-2.8-1-100
2.8	1	125	60	3	6	3	0.3	Z85-2.8-1-125
2.8	1	160	80	3	6	3	0.3	Z85-2.8-1-160
2.8	1	200	100	3	6	3	0.3	Z85-2.8-1-200
2.8	1	250	125	3	6	3	0.3	Z85-2.8-1-250
2.8	1	315	160	3	6	3	0.3	Z85-2.8-1-315
3	3	100	50	5	10	3	0.3	Z85-3-3-100
3	3	125	60	5	10	3	0.3	Z85-3-3-125
3	3	160	80	5	10	3	0.3	Z85-3-3-160
3	3	200	100	5	10	3	0.3	Z85-3-3-200
3	3	250	125	5	10	3	0.3	Z85-3-3-250
3	3	315	160	5	10	3	0.3	Z85-3-3-315
3.3	0.8	100	50	4	8	3	0.3	Z85-3.3-0.8-100
3.3	0.8	125	60	4	8	3	0.3	Z85-3.3-0.8-125
3.3	0.8	160	80	4	8	3	0.3	Z85-3.3-0.8-160
3.3	0.8	200	100	4	8	3	0.3	Z85-3.3-0.8-200
3.3	0.8	250	125	4	8	3	0.3	Z85-3.3-0.8-250
3.5	1	125	60	4	8	3	0.3	Z85-3.5-1-125
3.5	1	160	80	4	8	3	0.3	Z85-3.5-1-160
3.5	1	200	100	4	8	3	0.3	Z85-3.5-1-200
3.5	1	250	125	4	8	3	0.3	Z85-3.5-1-250
3.5	1.5	125	60	4.2	8	3	0.3	Z85-3.5-1.5-125
3.5	1.5	160	80	4.2	8	3	0.3	Z85-3.5-1.5-160
3.5	1.5	200	100	4.2	8	3	0.3	Z85-3.5-1.5-200
3.5	1.5	250	125	4.2	8	3	0.3	Z85-3.5-1.5-250
3.5	2	125	60	4.2	8	3	0.3	Z85-3.5-2-125



## Z85

Flat ejector pin with chamfer radii, 2-fold



a	b	L	L2	D1	D2	H	R	Order No.	a	b	L	L2	D1	D2	H	R	Order No.
3.5	2	160	80	4.2	8	3	0.3	Z85-3.5-2-160	4.5	0.8	400	200	5	10	3	0.3	Z85-4.5-0.8-400
3.5	2	200	100	4.2	8	3	0.3	Z85-3.5-2-200	4.5	1	80	40	5	10	3	0.3	Z85-4.5-1-80
3.5	2	250	125	4.2	8	3	0.3	Z85-3.5-2-250	4.5	1	100	50	5	10	3	0.3	Z85-4.5-1-100
3.8	0.5	80	40	4.2	8	3	0.3	Z85-3.8-0.5-80	4.5	1	125	60	5	10	3	0.3	Z85-4.5-1-125
3.8	0.5	100	50	4.2	8	3	0.3	Z85-3.8-0.5-100	4.5	1	160	80	5	10	3	0.3	Z85-4.5-1-160
3.8	0.5	125	60	4.2	8	3	0.3	Z85-3.8-0.5-125	4.5	1	200	100	5	10	3	0.3	Z85-4.5-1-200
3.8	0.5	160	80	4.2	8	3	0.3	Z85-3.8-0.5-160	4.5	1	250	125	5	10	3	0.3	Z85-4.5-1-250
3.8	0.6	80	40	4.2	8	3	0.3	Z85-3.8-0.6-80	4.5	1	315	160	5	10	3	0.3	Z85-4.5-1-315
3.8	0.6	100	50	4.2	8	3	0.3	Z85-3.8-0.6-100	4.5	1	400	200	5	10	3	0.3	Z85-4.5-1-400
3.8	0.6	125	60	4.2	8	3	0.3	Z85-3.8-0.6-125	4.5	1.2	80	40	5	10	3	0.3	Z85-4.5-1.2-80
3.8	0.6	160	80	4.2	8	3	0.3	Z85-3.8-0.6-160	4.5	1.2	100	50	5	10	3	0.3	Z85-4.5-1.2-100
3.8	0.6	200	100	4.2	8	3	0.3	Z85-3.8-0.6-200	4.5	1.2	125	60	5	10	3	0.3	Z85-4.5-1.2-125
3.8	0.6	250	125	4.2	8	3	0.3	Z85-3.8-0.6-250	4.5	1.2	160	80	5	10	3	0.3	Z85-4.5-1.2-160
3.8	0.7	100	50	4.2	8	3	0.3	Z85-3.8-0.7-100	4.5	1.2	200	100	5	10	3	0.3	Z85-4.5-1.2-200
3.8	0.7	125	60	4.2	8	3	0.3	Z85-3.8-0.7-125	4.5	1.2	250	125	5	10	3	0.3	Z85-4.5-1.2-250
3.8	0.7	160	80	4.2	8	3	0.3	Z85-3.8-0.7-160	4.5	1.2	315	160	5	10	3	0.3	Z85-4.5-1.2-315
3.8	0.7	200	100	4.2	8	3	0.3	Z85-3.8-0.7-200	4.5	1.2	400	200	5	10	3	0.3	Z85-4.5-1.2-400
3.8	0.7	250	125	4.2	8	3	0.3	Z85-3.8-0.7-250	4.5	1.5	100	50	5	10	3	0.3	Z85-4.5-1.5-100
3.8	0.8	80	40	4.2	8	3	0.3	Z85-3.8-0.8-80	4.5	1.5	125	60	5	10	3	0.3	Z85-4.5-1.5-125
3.8	0.8	100	50	4.2	8	3	0.3	Z85-3.8-0.8-100	4.5	1.5	160	80	5	10	3	0.3	Z85-4.5-1.5-160
3.8	0.8	125	60	4.2	8	3	0.3	Z85-3.8-0.8-125	4.5	1.5	200	100	5	10	3	0.3	Z85-4.5-1.5-200
3.8	0.8	160	80	4.2	8	3	0.3	Z85-3.8-0.8-160	4.5	1.5	250	125	5	10	3	0.3	Z85-4.5-1.5-250
3.8	0.8	200	100	4.2	8	3	0.3	Z85-3.8-0.8-200	4.5	1.5	315	160	5	10	3	0.3	Z85-4.5-1.5-315
3.8	0.8	250	125	4.2	8	3	0.3	Z85-3.8-0.8-250	4.5	1.5	400	200	5	10	3	0.3	Z85-4.5-1.5-400
3.8	0.8	315	160	4.2	8	3	0.3	Z85-3.8-0.8-315	5	3	125	60	6	12	5	0.5	Z85-5-3-125
3.8	0.8	400	200	4.2	8	3	0.3	Z85-3.8-0.8-400	5	3	160	80	6	12	5	0.5	Z85-5-3-160
3.8	1	80	40	4.2	8	3	0.3	Z85-3.8-1-80	5	3	200	100	6	12	5	0.5	Z85-5-3-200
3.8	1	100	50	4.2	8	3	0.3	Z85-3.8-1-100	5	3	250	125	6	12	5	0.5	Z85-5-3-250
3.8	1	125	60	4.2	8	3	0.3	Z85-3.8-1-125	5	3	315	160	6	12	5	0.5	Z85-5-3-315
3.8	1	160	80	4.2	8	3	0.3	Z85-3.8-1-160	5	3	400	200	6	12	5	0.5	Z85-5-3-400
3.8	1	200	100	4.2	8	3	0.3	Z85-3.8-1-200	5.5	0.7	125	60	6	12	5	0.5	Z85-5.5-0.7-125
3.8	1	250	125	4.2	8	3	0.3	Z85-3.8-1-250	5.5	0.8	100	50	6	12	5	0.5	Z85-5.5-0.8-100
3.8	1	315	160	4.2	8	3	0.3	Z85-3.8-1-315	5.5	0.8	125	60	6	12	5	0.5	Z85-5.5-0.8-125
3.8	1	400	200	4.2	8	3	0.3	Z85-3.8-1-400	5.5	0.8	160	80	6	12	5	0.5	Z85-5.5-0.8-160
3.8	1.2	80	40	4.2	8	3	0.3	Z85-3.8-1.2-80	5.5	0.8	200	100	6	12	5	0.5	Z85-5.5-0.8-200
3.8	1.2	100	50	4.2	8	3	0.3	Z85-3.8-1.2-100	5.5	0.8	250	125	6	12	5	0.5	Z85-5.5-0.8-250
3.8	1.2	125	60	4.2	8	3	0.3	Z85-3.8-1.2-125	5.5	0.8	315	160	6	12	5	0.5	Z85-5.5-0.8-315
3.8	1.2	160	80	4.2	8	3	0.3	Z85-3.8-1.2-160	5.5	0.8	400	200	6	12	5	0.5	Z85-5.5-0.8-400
3.8	1.2	200	100	4.2	8	3	0.3	Z85-3.8-1.2-200	5.5	1	80	40	6	12	5	0.5	Z85-5.5-1-80
3.8	1.2	250	125	4.2	8	3	0.3	Z85-3.8-1.2-250	5.5	1	100	50	6	12	5	0.5	Z85-5.5-1-100
3.8	1.2	315	160	4.2	8	3	0.3	Z85-3.8-1.2-315	5.5	1	125	60	6	12	5	0.5	Z85-5.5-1-125
3.8	1.2	400	200	4.2	8	3	0.3	Z85-3.8-1.2-400	5.5	1	160	80	6	12	5	0.5	Z85-5.5-1-160
4	4	125	60	6	12	5	0.5	Z85-4-4-125	5.5	1	200	100	6	12	5	0.5	Z85-5.5-1-200
4	4	160	80	6	12	5	0.5	Z85-4-4-160	5.5	1	250	125	6	12	5	0.5	Z85-5.5-1-250
4	4	200	100	6	12	5	0.5	Z85-4-4-200	5.5	1	315	160	6	12	5	0.5	Z85-5.5-1-315
4	4	250	125	6	12	5	0.5	Z85-4-4-250	5.5	1	400	200	6	12	5	0.5	Z85-5.5-1-400
4	4	315	160	6	12	5	0.5	Z85-4-4-315	5.5	1.2	80	40	6	12	5	0.5	Z85-5.5-1.2-80
4	4	400	200	6	12	5	0.5	Z85-4-4-400	5.5	1.2	100	50	6	12	5	0.5	Z85-5.5-1.2-100
4.5	0.6	125	60	5	10	3	0.3	Z85-4.5-0.6-125	5.5	1.2	125	60	6	12	5	0.5	Z85-5.5-1.2-125
4.5	0.7	125	60	5	10	3	0.3	Z85-4.5-0.7-125	5.5	1.2	160	80	6	12	5	0.5	Z85-5.5-1.2-160
4.5	0.8	100	50	5	10	3	0.3	Z85-4.5-0.8-100	5.5	1.2	200	100	6	12	5	0.5	Z85-5.5-1.2-200
4.5	0.8	125	60	5	10	3	0.3	Z85-4.5-0.8-125	5.5	1.2	250	125	6	12	5	0.5	Z85-5.5-1.2-250
4.5	0.8	160	80	5	10	3	0.3	Z85-4.5-0.8-160	5.5	1.2	315	160	6	12	5	0.5	Z85-5.5-1.2-315
4.5	0.8	200	100	5	10	3	0.3	Z85-4.5-0.8-200	5.5	1.2	400	200	6	12	5	0.5	Z85-5.5-1.2-400
4.5	0.8	250	125	5	10	3	0.3	Z85-4.5-0.8-250	5.5	1.5	100	50	6	12	5	0.5	Z85-5.5-1.5-100
4.5	0.8	315	160	5	10	3	0.3	Z85-4.5-0.8-315	5.5	1.5	125	60	6	12	5	0.5	Z85-5.5-1.5-125



## Z85

Flat ejector pin with chamfer radii, 2-fold



6

a	b	L	L2	D1	D2	H	R	Order No.	a	b	L	L2	D1	D2	H	R	Order No.
5.5	1.5	160	80	6	12	5	0.5	Z85-5.5-1.5-160	7.5	2	250	125	8	14	5	0.5	Z85-7.5-2-250
5.5	1.5	200	100	6	12	5	0.5	Z85-5.5-1.5-200	7.5	2	315	160	8	14	5	0.5	Z85-7.5-2-315
5.5	1.5	250	125	6	12	5	0.5	Z85-5.5-1.5-250	7.5	2	400	200	8	14	5	0.5	Z85-7.5-2-400
5.5	1.5	315	160	6	12	5	0.5	Z85-5.5-1.5-315	7.5	4	125	60	9	14	5	0.5	Z85-7.5-4-125
5.5	1.5	400	200	6	12	5	0.5	Z85-5.5-1.5-400	7.5	4	160	80	9	14	5	0.5	Z85-7.5-4-160
5.5	2	100	50	6	12	5	0.5	Z85-5.5-2-100	7.5	4	200	100	9	14	5	0.5	Z85-7.5-4-200
5.5	2	125	60	6	12	5	0.5	Z85-5.5-2-125	7.5	4	250	125	9	14	5	0.5	Z85-7.5-4-250
5.5	2	160	80	6	12	5	0.5	Z85-5.5-2-160	7.5	4	315	160	9	14	5	0.5	Z85-7.5-4-315
5.5	2	200	100	6	12	5	0.5	Z85-5.5-2-200	8	8	160	80	12	18	7	0.8	Z85-8-8-160
5.5	2	250	125	6	12	5	0.5	Z85-5.5-2-250	8	8	200	100	12	18	7	0.8	Z85-8-8-200
5.5	2	315	160	6	12	5	0.5	Z85-5.5-2-315	8	8	250	125	12	18	7	0.8	Z85-8-8-250
5.5	2	400	200	6	12	5	0.5	Z85-5.5-2-400	8	8	315	160	12	18	7	0.8	Z85-8-8-315
5.5	4	125	60	7	12	5	0.5	Z85-5.5-4-125	8.5	5	160	80	10	16	5	0.5	Z85-8.5-5-160
5.5	4	160	80	7	12	5	0.5	Z85-5.5-4-160	8.5	5	200	100	10	16	5	0.5	Z85-8.5-5-200
5.5	4	200	100	7	12	5	0.5	Z85-5.5-4-200	8.5	5	250	125	10	16	5	0.5	Z85-8.5-5-250
5.5	4	250	125	7	12	5	0.5	Z85-5.5-4-250	8.5	5	315	160	10	16	5	0.5	Z85-8.5-5-315
5.5	4	315	160	7	12	5	0.5	Z85-5.5-4-315	8.5	6	160	80	10.5	16	5	0.5	Z85-8.5-6-160
5.5	5.5	125	60	8	14	5	0.5	Z85-5.5-5.5-125	8.5	6	200	100	10.5	16	5	0.5	Z85-8.5-6-200
5.5	5.5	160	80	8	14	5	0.5	Z85-5.5-5.5-160	8.5	6	250	125	10.5	16	5	0.5	Z85-8.5-6-250
5.5	5.5	200	100	8	14	5	0.5	Z85-5.5-5.5-200	8.5	6	315	160	10.5	16	5	0.5	Z85-8.5-6-315
5.5	5.5	250	125	8	14	5	0.5	Z85-5.5-5.5-250	9.5	1.5	125	60	10	16	5	0.5	Z85-9.5-1.5-125
5.5	5.5	315	160	8	14	5	0.5	Z85-5.5-5.5-315	9.5	1.5	160	80	10	16	5	0.5	Z85-9.5-1.5-160
6.5	3.5	125	60	8	14	5	0.5	Z85-6.5-3.5-125	9.5	1.5	200	100	10	16	5	0.5	Z85-9.5-1.5-200
6.5	3.5	160	80	8	14	5	0.5	Z85-6.5-3.5-160	9.5	1.5	250	125	10	16	5	0.5	Z85-9.5-1.5-250
6.5	3.5	200	100	8	14	5	0.5	Z85-6.5-3.5-200	9.5	1.5	315	160	10	16	5	0.5	Z85-9.5-1.5-315
6.5	3.5	250	125	8	14	5	0.5	Z85-6.5-3.5-250	9.5	1.5	400	200	10	16	5	0.5	Z85-9.5-1.5-400
6.5	3.5	315	160	8	14	5	0.5	Z85-6.5-3.5-315	9.5	2	125	60	10	16	5	0.5	Z85-9.5-2-125
7.5	0.8	125	60	8	14	5	0.5	Z85-7.5-0.8-125	9.5	2	160	80	10	16	5	0.5	Z85-9.5-2-160
7.5	0.8	160	80	8	14	5	0.5	Z85-7.5-0.8-160	9.5	2	200	100	10	16	5	0.5	Z85-9.5-2-200
7.5	0.8	200	100	8	14	5	0.5	Z85-7.5-0.8-200	9.5	2	250	125	10	16	5	0.5	Z85-9.5-2-250
7.5	0.8	250	125	8	14	5	0.5	Z85-7.5-0.8-250	9.5	2	315	160	10	16	5	0.5	Z85-9.5-2-315
7.5	1	125	60	8	14	5	0.5	Z85-7.5-1-125	9.5	2	400	200	10	16	5	0.5	Z85-9.5-2-400
7.5	1	160	80	8	14	5	0.5	Z85-7.5-1-160	9.5	3	160	80	10	16	5	0.5	Z85-9.5-3-160
7.5	1	200	100	8	14	5	0.5	Z85-7.5-1-200	9.5	3	200	100	10	16	5	0.5	Z85-9.5-3-200
7.5	1	250	125	8	14	5	0.5	Z85-7.5-1-250	9.5	8	160	80	12.5	18	7	0.8	Z85-9.5-8-160
7.5	1	315	160	8	14	5	0.5	Z85-7.5-1-315	9.5	8	200	100	12.5	18	7	0.8	Z85-9.5-8-200
7.5	1	400	200	8	14	5	0.5	Z85-7.5-1-400	9.5	8	250	125	12.5	18	7	0.8	Z85-9.5-8-250
7.5	1.2	100	50	8	14	5	0.5	Z85-7.5-1.2-100	9.5	8	315	160	12.5	18	7	0.8	Z85-9.5-8-315
7.5	1.2	125	60	8	14	5	0.5	Z85-7.5-1.2-125	11.5	2	160	80	12	18	7	0.8	Z85-11.5-2-160
7.5	1.2	160	80	8	14	5	0.5	Z85-7.5-1.2-160	11.5	2	200	100	12	18	7	0.8	Z85-11.5-2-200
7.5	1.2	200	100	8	14	5	0.5	Z85-7.5-1.2-200	11.5	2	250	125	12	18	7	0.8	Z85-11.5-2-250
7.5	1.2	250	125	8	14	5	0.5	Z85-7.5-1.2-250	11.5	2	315	160	12	18	7	0.8	Z85-11.5-2-315
7.5	1.2	315	160	8	14	5	0.5	Z85-7.5-1.2-315	11.5	2.5	160	80	12	18	7	0.8	Z85-11.5-2.5-160
7.5	1.2	400	200	8	14	5	0.5	Z85-7.5-1.2-400	11.5	2.5	200	100	12	18	7	0.8	Z85-11.5-2.5-200
7.5	1.5	100	50	8	14	5	0.5	Z85-7.5-1.5-100	11.5	2.5	250	125	12	18	7	0.8	Z85-11.5-2.5-250
7.5	1.5	125	60	8	14	5	0.5	Z85-7.5-1.5-125	11.5	2.5	315	160	12	18	7	0.8	Z85-11.5-2.5-315
7.5	1.5	160	80	8	14	5	0.5	Z85-7.5-1.5-160	11.5	2.5	400	200	12	18	7	0.8	Z85-11.5-2.5-400
7.5	1.5	200	100	8	14	5	0.5	Z85-7.5-1.5-200	12	10	200	100	16	22	7	0.8	Z85-12-10-200
7.5	1.5	250	125	8	14	5	0.5	Z85-7.5-1.5-250	12	10	250	125	16	22	7	0.8	Z85-12-10-250
7.5	1.5	315	160	8	14	5	0.5	Z85-7.5-1.5-315	12	10	315	160	16	22	7	0.8	Z85-12-10-315
7.5	1.5	400	200	8	14	5	0.5	Z85-7.5-1.5-400	16	12	200	100	20	26	8	1	Z85-16-12-200
7.5	2	80	40	8	14	5	0.5	Z85-7.5-2-80	16	12	250	125	20	26	8	1	Z85-16-12-250
7.5	2	100	50	8	14	5	0.5	Z85-7.5-2-100	16	12	315	160	20	26	8	1	Z85-16-12-315
7.5	2	125	60	8	14	5	0.5	Z85-7.5-2-125	18	8	200	100	20	26	8	1	Z85-18-8-200
7.5	2	160	80	8	14	5	0.5	Z85-7.5-2-160	18	8	250	125	20	26	8	1	Z85-18-8-250
7.5	2	200	100	8	14	5	0.5	Z85-7.5-2-200	18	8	315	160	20	26	8	1	Z85-18-8-315