

### Formensenker für Posaunenhalstempel

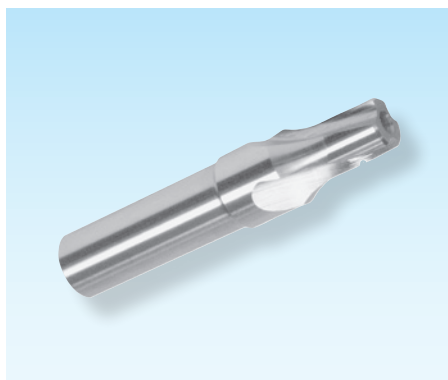

**W8460-HSS-**

Mat.: HSS (1.3343) /  
DIN 9861 D



W8460-HSS-d1



### Countersinker for punch with trombone collar

### Foret aléreur pour poinçons avec collerette de trombone

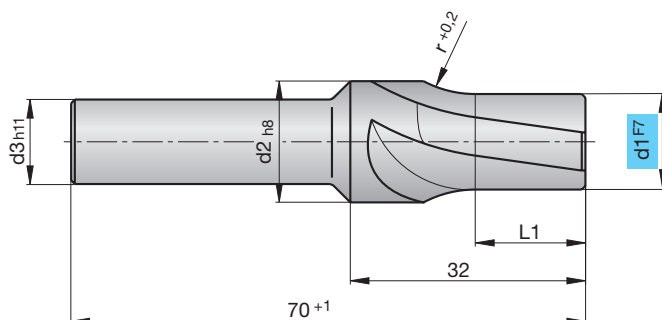

4

X\* – Stufung in mm  
– graduation in mm  
– progression en mm



SN1842

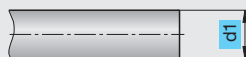

SN1841



SN1843



d1	d2	d3	r	L1	X*(d1)
2,0	3,3	3,3	3,5	5,0	
2,1 - 2,2	3,5	3,5	5,0	5,0	0,1
2,3 - 2,5	3,8	3,8	5,0	5,0	0,1
2,6 - 2,9	4,3	4,3	6,5	7,0	0,1
3,0 - 3,4	4,9	4,9	6,5	7,0	0,1
3,5 - 3,9	5,4	5,4	8,0	7,0	0,1
4,0 - 4,4	5,9	5,9	8,0	8,0	0,1
4,5 - 4,9	6,4	6,4	8,0	8,0	0,1
5,0 - 5,4	7,4	7,4	10,0	10,0	0,1
5,5 - 5,9	8,5	8,5	10,0	10,0	0,1
6,0	9,5	9,5	10,0	10,0	
6,5 - 7,0	10,5	10,0	12,0	12,0	0,5
7,5 - 8,0	11,5	10,0	12,0	12,0	0,5
8,5 - 9,0	13,5	10,0	15,0	12,0	0,5
9,5 - 10,0	14,5	10,0	15,0	12,0	0,5
10,5 - 11,0	15,5	10,0	15,0	15,0	0,5
11,5 - 12,0	16,5	10,0	15,0	15,0	0,5
12,5 - 13,0	17,5	10,0	15,0	15,0	0,5
13,5 - 14,0	18,5	10,0	15,0	15,0	0,5
14,5 - 15,0	19,5	10,0	15,0	15,0	0,5
15,5 - 16,0	20,5	10,0	15,0	15,0	0,5
16,5 - 17,0	21,5	16,0	15,0	15,0	0,5
17,5 - 18,0	22,5	16,0	15,0	15,0	0,5
18,5 - 19,0	23,5	16,0	15,0	15,0	0,5
19,5 - 20,0	25,5	16,0	15,0	15,0	0,5