

Gasdruckfedern kleine Abmessungen

Gas springs small dimensions

Ressorts à gaz dimensions petites

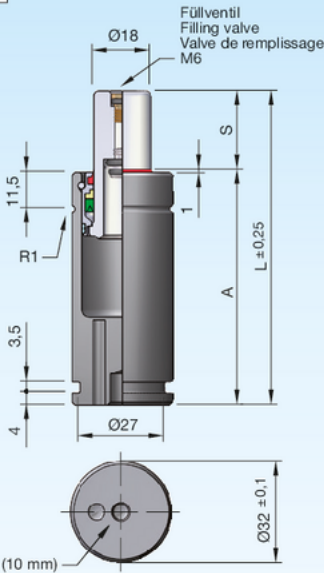

Druckmedium	Pressure medium	Médium de pression	Stickstoff (N ₂)
Max. Fülldruck	Max. filling pressure	Pression de rempl. max.	175 bar
Min. Fülldruck	Min. filling pressure	Pression de rempl. min.	25 bar
Max. Betriebs-temperatur	Max. working temperature	Température de service max.	80 °C
Temperaturabhängige Druckerhöhung	Pressure increase due to temperature	Accroissement de pression sous l'influence de la temp.	0,33 %/1 °C
Instandhaltungssatz	Maintenance kit	Jeu de maintenance	SN2990-GP32
Max. Kolben-geschwindigkeit	Max. piston speed	Vitesse max. du piston	1,2 m/s

3

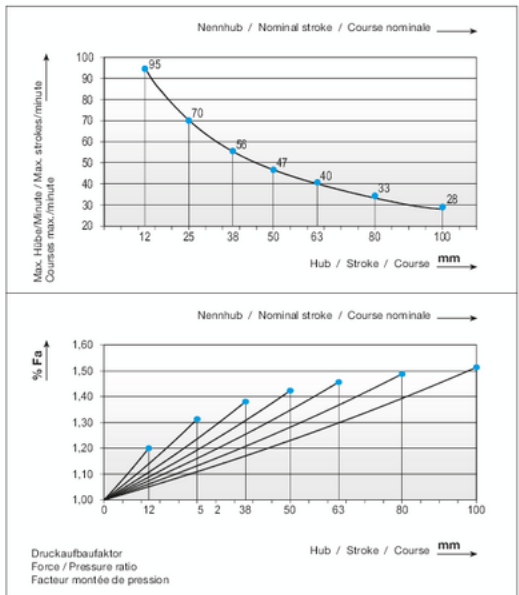

Einbauvarianten / Installation variants / Variantes de montage

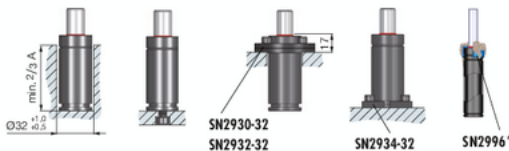

SN2805-450-		S	Type	A	L	V [l]	Fa [cm ²]	kg
 S = Hub / Stroke / Course bar = Fülldruck / Filling pressure / Pression de remplissage	SN2805-450-S-Type	12	1	72	84	0,008	2,54	0,36
		25	2	85	110	0,017	2,54	0,37
		38	3	98	136	0,025	2,54	0,41
		50	4	110	160	0,033	2,54	0,48
		63		123	186	0,041	2,54	0,49
		80		140	220	0,052	2,54	0,57
		100		160	260	0,065	2,54	0,65
Type	Farbcode Colour code Code couleur	daN	daN	bar				
1	Grün / Green / Vert	100 (-5)	165	40				
2	Blau / Blue / Bleu	200 (-10)	330	80				
3	Rot / Red / Rouge	300 (-15)	500	120				
4	Gelb / Yellow / Jaune	450 (-20)	725	175				
Andere Kräfte / Other forces / Autres forces		60-450	≈25-725	25-175				

i SN2996* = Seite / Page 2.3.254