

Gasdruckfedern kleine Abmessungen

Gas springs small dimensions

Ressorts à gaz dimensions petites

3

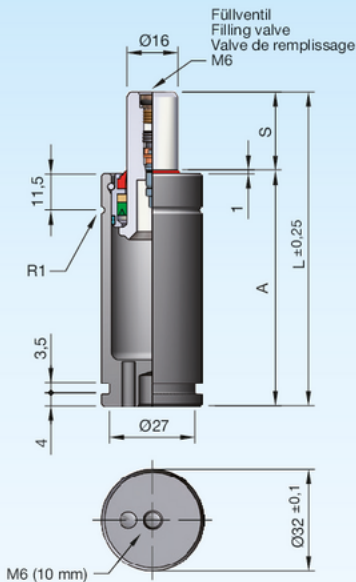

Druckmedium	Pressure medium	Médium de pression	Stickstoff (N ₂)
Max. Fülldruck	Max. filling pressure	Pression de rempl. max.	150 bar
Min. Fülldruck	Min. filling pressure	Pression de rempl. min.	25 bar
Max. Betriebstemperatur	Max. working temperature	Température de service max.	80 °C
Temperaturabhängige Druckerhöhung	Pressure increase due to temperature	Accroissement de pression sous l'influence de la temp.	0,33 %/1 °C
Instandhaltungssatz	Maintenance kit	Jeu de maintenance	SN2990-G32
Max. Kolbengeschwindigkeit	Max. piston speed	Vitesse max. du piston	1,6 m/s

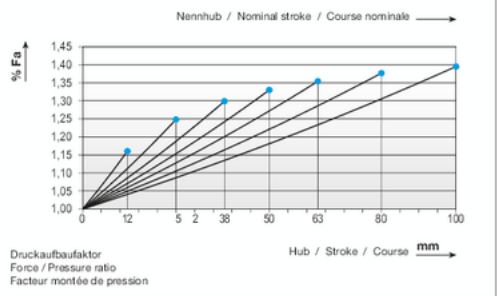
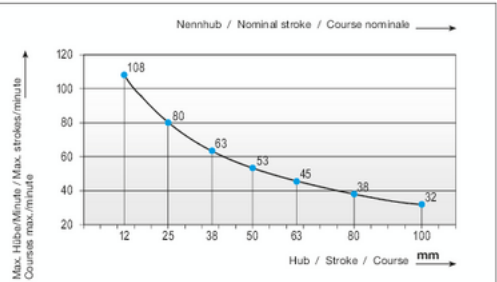

Einbauvarianten / Installation variants / Variantes de montage

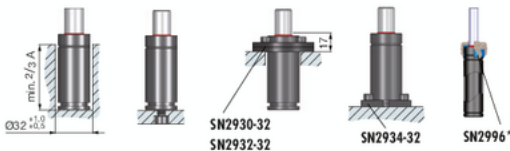

SN2805-300-		S	Type	A	L	V [l]	Fa [cm ²]	kg
 SN2805-300-S-Type		12	1	72	84	0,007	2,01	0,35
		25	2	85	110	0,015	2,01	0,36
		38	3	98	136	0,023	2,01	0,40
		50	4	110	160	0,030	2,01	0,47
		63		123	186	0,038	2,01	0,48
		80		140	220	0,049	2,01	0,56
		100		160	260	0,061	2,01	0,64
Type	Farbcode Colour code Code couleur	daN	daN					bar
1	Grün / Green / Vert	100 (-5)	150					50
2	Blau / Blue / Bleu	200 (-10)	300					100
3	Rot / Red / Rouge	250 (-15)	375					125
4	Gelb / Yellow / Jaune	300 (-20)	450					150
Andere Kräfte / Other forces / Autres forces		50-300	≈75-450					25-150

i SN2996* = Seite / Page 2.3.254