

>> Editorial <<



More modern, more comfortable: Elina Flaum, responsible for the project, presents the new website and the online-shop of STRACK NORMA

STRACK STANDARD PARTS all over the world

Successful relaunch of the company's website numerous new features

An internet presentation is an excellent marketing instrument, particularly for companies with a high service structure and a pronounced customer oriented service. For good reasons STRACK NORMA has made a relaunch of its internet sites. After some months of intensive work now a modern, comfortable and multilingual platform for the toolmaker is created.

Kosima Bardtke can breathe freely. After many months of work, particularly of the internal IT-department, the relaunch of the homepage is completed.

"The multilingual website was extensively overhauled and adapted to the current technical standard," explains the Marketing Manager. But it particularly offers lots of comfort to the producers of injection moulding dies and die casting tools as well as to the producers of stamping- and forming tools.

In the download center the user finds all important information about the company and the products, starting with the information sheets over operating instructions up to important updates of CAD – as well as DVD data. The toolmaker needs a lot of input and this normally at once", Kosima Bardtke knows what is important for the customers. STRACK NORMA reacted accordingly.

Thanks to the homepage it can be calculated immediately. The pre-planning in the company of the customer can begin directly and an ordering procedure can be initiated at once in the internet shop which is simple to use. Hereby the production times are reduced. Also the procurement of spare parts is accelerated, whereby the standstill periods are considerably reduced.



It is done! The completely reworked homepage is online. Offering more than 200.000 different articles this was a lot of additional work for the IT-department in the past months. My thanks go to all involved employees.

The result is more than presentable. The Homepage and the Onlineshop are more modern and particularly more comfortable in handling. Simply visit our sites and be impressed by the new features under strack.de.

For our worldwide customers this is a further step in the future of the toolmaking. There is no time to sit back. We definitely haven't done this. We are showing this presenting our continuous product improvements in the Main metropolis Frankfurt. At the end of the year once again new articles are presented on the fair EuroMold.

Have fun while reading!

Dag Friedrich

Managing Director



The core of the homepage is the presentation of the products in 2D and 3D models. The data can be included in the construction by the download functions with just a few clicks. These are high quality CAD data which can always be downloaded at the current state of technology. Even complex components with many adjustment possibilities are online available for the user. A detailed operating

Continued on the next page >>

instruction which is available in the download center explains how it works. "If, however, problems arise, we are the right contact", Kosima Bardtke explains how important the personal contact is for the company STRACK.

The specialist for standard parts is active around the globe, thus all contents are available in three languages. You can choose between German, English and French. The online-shop even offers a selection of 10 different languages. All contents, particularly the programming of the CAD data were entered by the IT-department of STRACK NORMA.

"The internal cooperation between the individual departments has functioned excellently", praises Kosima Bardtke. ■

Tool calibration facilitated

Toothed spacer plates SN 4530

The calibration of tools is an unpleasant work. Now STRACK NORMA offers the spacer plates SN4530 to facilitate this.



The toothed spacer plates allow a fine height adjustment in the interaction with the two tool halves. Because of a slight tilt of the rows of teeth to each other, the height can be changed by 0,02 mm by the sliding of the upper plate to the lower plate by one tooth. This allows a maximal tuning range per unit of 0,24 to 0,28 mm. ■

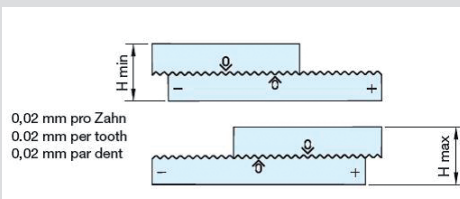

Good products even better

The centering unit Z50 becomes Z 51

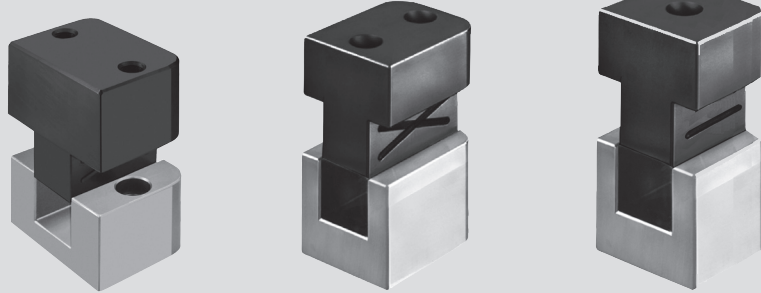

High precision centering units of STRACK NORMA may not be lacking in a tool. The evergreen was further improved by a new DLC-coating to respond to the requirements for even higher service performances of the precision toolmaking.

The centering unit with the STRACK-standard Z51 replaces the proven centering unit Z 50 completely.

Being absolutely identical in construction the unit Z51 offers an extended service life – and this without additional charge. ■

SNS-sliding elements resist wearing

Now SNS sintered metal is available in further dimensions

In everyday use sliding elements are exposed to an enormous mechanical stress. Now STRACK NORMA applies a new sintered metal to increase the running lives for these products considerably.

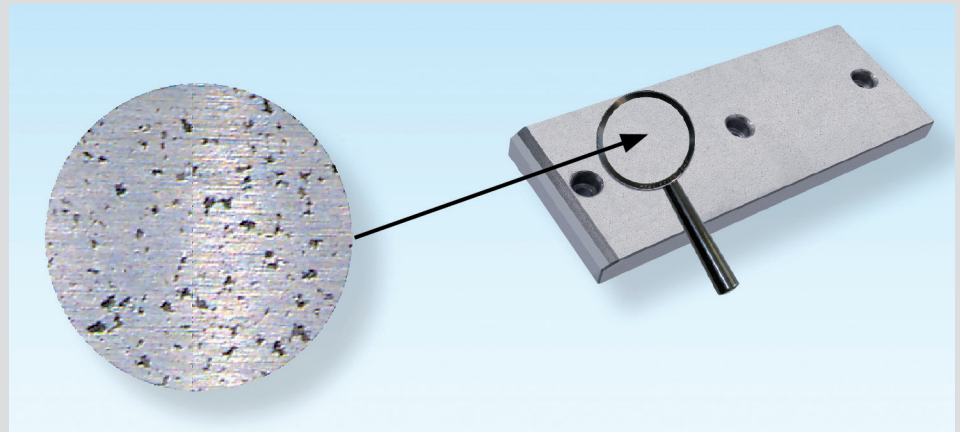

The new generation of bearing elements is now a porous sintered metal, which is reinforced with steel and based on iron. The bearing elements characterize by their extremely high resistance to wear at medium to high speed.

The sintered metal is applied to a steel base body, which gives a higher strength to the sliding element. The advantages of these elements arise from a maximal sliding speed which is at least 4,5 fold higher, from a three-times higher unlubricated service life at a three-times higher PV-value indicated in daN/cm²xm/min.

A further advantage is the considerably increased maximal working temperature of 250 °C, which makes the material particularly interesting for the utilization in hot forming tools. Here in the practical application the application engineers could realize a service life being 8-times higher compared to bronze with solid lubricant.

After the successful introduction of the SNS-sliding elements in the successful PowerMax standard cam program STRACK NORMA has enlarged the product range of the maintenance-free sliding elements correspondingly. ■

Construction tip: Angle pin Z 69

Quick mounting and cost reduction in practice

Proven products are regularly optimized at STRACK NORMA. Thereby the articles are kept up to day following the development in the modern toolmaking. Thus also the on the market proven angle pin has been redesigned.

According to customer requirements the angle pin R650 with the incorporated hexagon socket for a quick and comfortable mounting, was additionally tolerated in the hundredths range in length and rounding radius. Thereby the angle pin hits the determined point on the sliding element. Moreover the user can define slide ways.

This highly precise element is a considerable time- and cost reduction for the toolmaking. Furthermore concerning this angle pin the adaptation of the tool environment is not necessary.

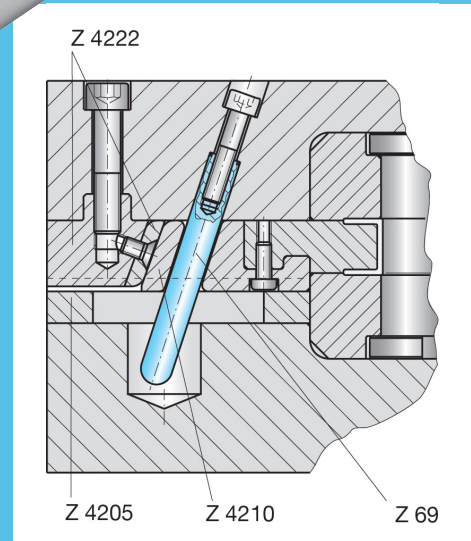
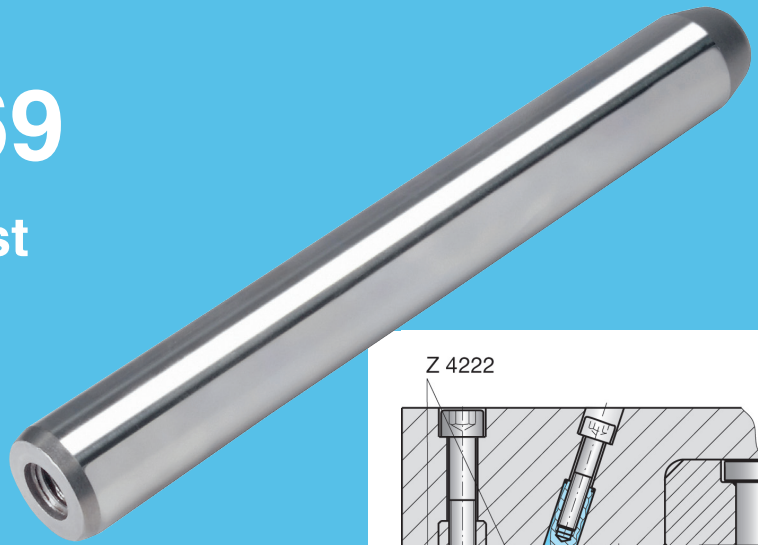

MASTIPline: hot runner nozzles for each utilisation

Special nozzles for the processing of POM and glass-fiber reinforced material

For the hot channel technology STRACK NORMA offers with MASTIPline a complete product family for a flexible and cost-effective construction of forming tools. There are specially designed nozzle variants for the processing of defined materials.

In the construction phase the user can access with the series X to all necessary details in the hot channel technology which are thus ensuring an optimal result. The hotrunner nozzles of the whole series which have a modular construction characterize by a high quality, practice-oriented and robust components and a high operating safety. Further attributes of the product family are the unsurpassed and continuous performance for demanding applications as well as the simple insertion and installation requirements.

The series X consists of the nozzles of the MX-, BX-, and SX family, which share the same tips and gating options; thus a variety of thermal gating possibilities results.

Moreover you can receive also needle valve gate options to meet the most demanding application cases, which require either an exceptional gate quality, higher flowrates or sequential filling processes.

The complete series has a modular construction and the articles are also delivered separately. This allows the user to remain flexible. If the products have to be maintained, the necessary work is very simple and thus very

maintenance-friendly. Concerning this series it is not necessary to send the nozzles back to the manufacturer to repair them.

In the development of the nozzle family concerning the processing of glass-fibre reinforced material attention was paid to high service lives. These are achieved by specifically designed carbide tips.

If polyoxymethylene (POM), a high molecular thermoplastic material, is processed, the torpedo tips are made from copper beryllium and have been placed over a carbide metal tip. Thus concerning this material the tips for the heating can be used without problems. ■





Comfortably from A to B

Safety ring bolt adapter SN 5655

Moving components quickly from A to B is a must in the modern toolmaking. Especially for the current standard cam series of STRACK NORMA the ring safety bolt adapter SN 5655 was developed.

In the installation condition this adapter is fixed with one hand grip at the standard cam. Thereby the positioning of the adapter is flexible. Carrying screw threads which were used before for the transport belong to the past. ■

STRACK NORMA on the fair EuroMold



Andreas Geyer and his sales team are looking forward to your visit.

In this year STRACK NORMA was presented with a booth on numerous international and regional fairs. According to the company's philosophy to be particularly on spot, the producers of injection moulding dies and die casting tools as well as producers of stamping- and forming tools have the possibility to search for the personal contact with the application engineers and the sales representatives.

As in every year this year's fair marathon is finished with the participation in the fair EuroMold 2012. The global fair for the

tool- and mould making, design and product development takes place as usual in Frankfurt – this time from 27th to 30th November. STRACK presents itself at the same place as in the previous year, in hall 9.0 at booth A 101.

2013 will be again a K-year. Of course the standard part specialist is represented on the world's largest plastics fair in Düsseldorf. Customers wishing a contact beyond the respective fair can contact us personally. Then a sales representative will set up an appointment with you. ■



You find us in hall 9.0, booth A101

Impressum

The „Normalienreport“ is an information service of STRACK NORMA GmbH & Co. KG
Königsberger Straße 11
D-58511 Lüdenscheid
Tel.: +49 (0)2351 8701 -0
Fax: +49 (0)2351 8701 -100
www.strack.de

Konzeption, Text und Layout:
[vogomedia]
Marketing & Kommunikation
Friedrich-Ebert-Str. 294-296
D-58566 Kierspe
www.vogomedia.de

STRACK® intern Anniversaries

STRACK NORMA congratulates the employees belonging to the STRACK family for 10 years.

Congratulations!

Amende, Frank	June 2012
Kuper, Sascha	July 2012
Kioschis, Kirsten	August 2012
Hoffmann, Tanja	September 2012
Mengen, Aysun	September 2012
Saracino, Dennis	September 2012
Bobitka, Petra	Oktober 2012

and the employees belonging to the STRACK family for 25 years

Mitter, Hans Georg December 2012