

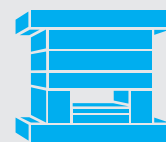









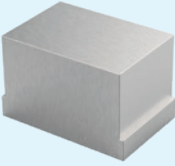
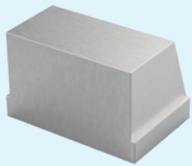
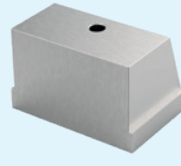

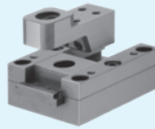
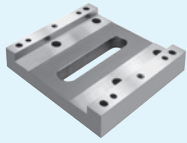
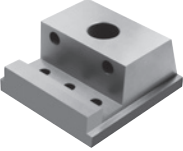





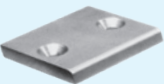
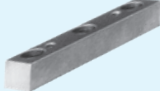

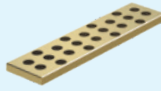
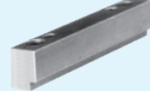
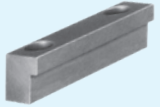
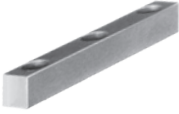











ENTFORMUNGSELEMENTE – DIREKT
DEMOULDING ELEMENTS – DIRECT
ELEMENTS DE DEMOULAGE – DIRECTS

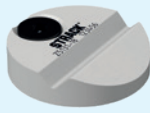

5

STRACK®

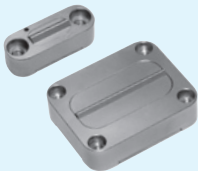
NORMALIEN

 Z42100 5.5.1	 Z42105 5.5.3	 Z42110 5.5.5	 Großschieber in Sonderausführung Large slides in special design Coulisseaux de grande dimension ou design spécial Z42110 5.5.7	 Z4200 5.6	 Z4205 5.10
 Z4210 5.11	 Z42900 5.11.2	 Z42110 5.11.3	 Z4211 5.12	 Z4220 5.13	 Z4222 5.14
 Z4230 5.15	 Z4240 5.16	 Z4165 5.20	 Z4166 5.21	 Z4242 5.22	 Z4244 5.24
 Z4248 5.26	 Z4278 5.28	 DLC  Z4279 5.30	 Z4085 5.31	 Z4090 5.31	 Z4290 5.34
 Z4290L 5.35.1	 Z4292 5.36	 Z4293 5.38	 Z4294 5.40	 Z4294L 5.41.1	 Z4295 5.42
 Z4296 5.43	 Z4296L 5.43.1	 Z4298 5.44			
 Z5129/5130 5.48	 Z5131 5.49	 Z5133/5134 5.50	 Z5135 5.52	 Z5136 5.52	 Z5140 5.54
 Z5141 5.56					

SCHIEBERELEMENTE
SLIDE ELEMENTS
ELEMENTS DE COULISSEAU



STRACK®

NORMALIEN

Großschieber

Large slides

Coulisseaux de grande dimension

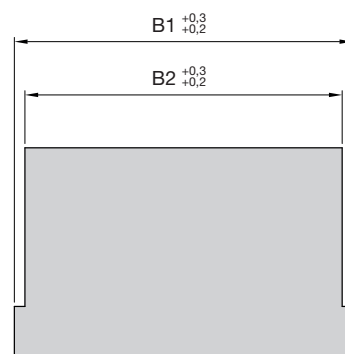
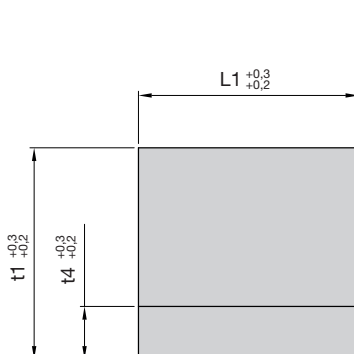
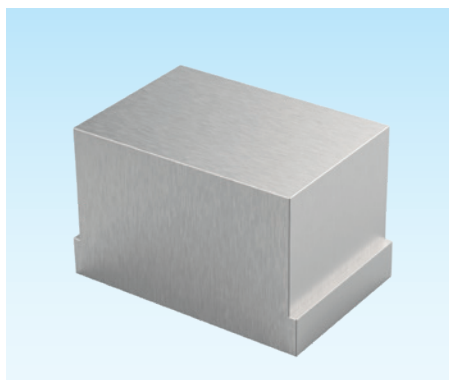

Z42100-

Mat.: 1.2311/1.2343/
1.2767

Z42100-B2-t1-
L1-Mat



5

B2	t1	L1	Mat	B1	t4
100	80	75	2311	112	18
100	80	75	2343	112	18
100	80	75	2767	112	18
120	80	75	2311	132	18
120	80	75	2343	132	18
120	80	75	2767	132	18
140	80	75	2311	152	18
140	80	75	2343	152	18
140	80	75	2767	152	18
160	80	75	2311	172	18
160	80	75	2343	172	18
160	80	75	2767	172	18
180	80	75	2311	192	18
180	80	75	2343	192	18
180	80	75	2767	192	18
100	100	100	2311	112	25
100	100	100	2343	112	25
100	100	100	2767	112	25
120	100	100	2311	132	25
120	100	100	2343	132	25
120	100	100	2767	132	25
140	100	100	2311	152	25
140	100	100	2343	152	25
140	100	100	2767	152	25
160	100	100	2311	172	25
160	100	100	2343	172	25
160	100	100	2767	172	25
180	100	100	2311	192	25
180	100	100	2343	192	25
180	100	100	2767	192	25
100	120	125	2311	112	30
100	120	125	2343	112	30

Z42100-



B2	t1	L1	Mat	B1	t4
100	120	125	2767	112	30
120	120	125	2311	132	30
120	120	125	2343	132	30
120	120	125	2767	132	30
140	120	125	2311	152	30
140	120	125	2343	152	30
140	120	125	2767	152	30
160	120	125	2311	172	30
160	120	125	2343	172	30
160	120	125	2767	172	30
180	120	125	2311	192	30
180	120	125	2343	192	30
180	120	125	2767	192	30

Großschieber

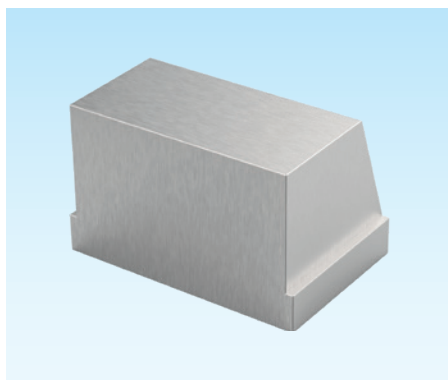

Large slides

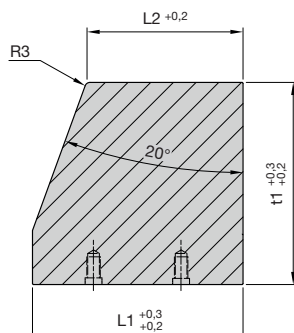

Coulisseaux de grande dimension

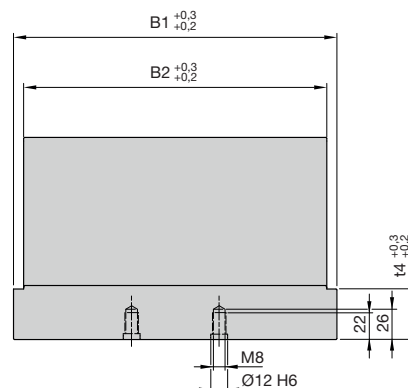

Z42105-

Mat.: 1.2311/1.2343/
1.2767

Z42105-B2-t1-
L1-Mat



5

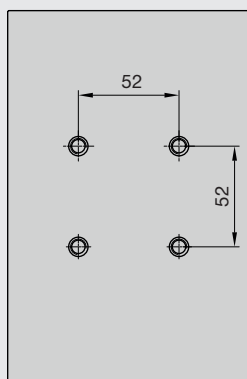

Bohrungen für Null-Punkt Spannsysteme.

Holes for zero-point clamping systems.

Trous pour systèmes de serrage à point zero.

B2	t1	L1	Mat	B1	t4	L2
100	80	75	2311	112	18	53
100	80	75	2343	112	18	53
100	80	75	2767	112	18	53
120	80	75	2311	132	18	53
120	80	75	2343	132	18	53
120	80	75	2767	132	18	53
140	80	75	2311	152	18	53
140	80	75	2343	152	18	53
140	80	75	2767	152	18	53
160	80	75	2311	172	18	53
160	80	75	2343	172	18	53
160	80	75	2767	172	18	53
180	80	75	2311	192	18	53
180	80	75	2343	192	18	53
180	80	75	2767	192	18	53
100	100	100	2311	112	25	73
100	100	100	2343	112	25	73
100	100	100	2767	112	25	73
120	100	100	2311	132	25	73
120	100	100	2343	132	25	73
120	100	100	2767	132	25	73
140	100	100	2311	152	25	73
140	100	100	2343	152	25	73
140	100	100	2767	152	25	73
160	100	100	2311	172	25	73
160	100	100	2343	172	25	73
160	100	100	2767	172	25	73
180	100	100	2311	192	25	73
180	100	100	2343	192	25	73
180	100	100	2767	192	25	73
100	120	125	2311	112	30	93
100	120	125	2343	112	30	93

Z42105-



B2	t1	L1	Mat	B1	t4	L2
100	120	125	2767	112	30	93
120	120	125	2311	132	30	93
120	120	125	2343	132	30	93
120	120	125	2767	132	30	93
140	120	125	2311	152	30	93
140	120	125	2343	152	30	93
140	120	125	2767	152	30	93
160	120	125	2311	172	30	93
160	120	125	2343	172	30	93
160	120	125	2767	172	30	93
180	120	125	2311	192	30	93
180	120	125	2343	192	30	93
180	120	125	2767	192	30	93

Großschieber

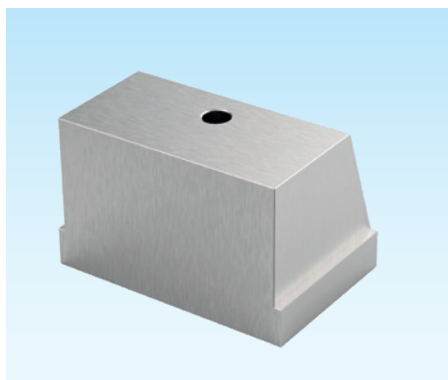

Large slides

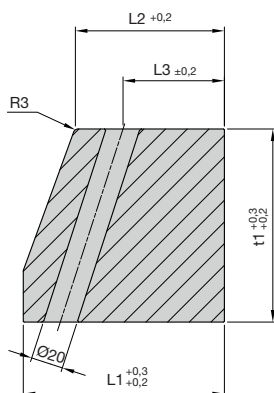

Coulisseaux de grande dimension

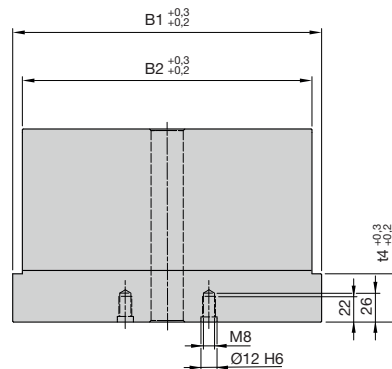

Z42110-

Mat.: 1.2311/1.2343/
1.2767

Z42110-B2-t1-
L1-Mat



5

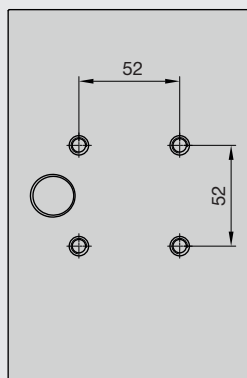

Bohrungen für Null-Punkt Spannsysteme.

Holes for zero-point clamping systems.

Trous pour systèmes de serrage à point zero.

B2	t1	L1	Mat	B1	t4	L2	L3
100	80	75	2311	112	18	53	31,7
100	80	75	2343	112	18	53	31,7
100	80	75	2767	112	18	53	31,7
120	80	75	2311	132	18	53	31,7
120	80	75	2343	132	18	53	31,7
120	80	75	2767	132	18	53	31,7
140	80	75	2311	152	18	53	31,7
140	80	75	2343	152	18	53	31,7
140	80	75	2767	152	18	53	31,7
160	80	75	2311	172	18	53	31,7
160	80	75	2343	172	18	53	31,7
160	80	75	2767	172	18	53	31,7
180	80	75	2311	192	18	53	31,7
180	80	75	2343	192	18	53	31,7
180	80	75	2767	192	18	53	31,7
100	100	100	2311	112	25	73	47,5
100	100	100	2343	112	25	73	47,5
100	100	100	2767	112	25	73	47,5
120	100	100	2311	132	25	73	47,5
120	100	100	2343	132	25	73	47,5
120	100	100	2767	132	25	73	47,5
140	100	100	2311	152	25	73	47,5
140	100	100	2343	152	25	73	47,5
140	100	100	2767	152	25	73	47,5
160	100	100	2311	172	25	73	47,5
160	100	100	2343	172	25	73	47,5
160	100	100	2767	172	25	73	47,5
180	100	100	2311	192	25	73	47,5
180	100	100	2343	192	25	73	47,5
180	100	100	2767	192	25	73	47,5
100	120	125	2311	112	30	93	63
100	120	125	2343	112	30	93	63

Z42110-



B2	t1	L1	Mat	B1	t4	L2	L3
100	120	125	2767	112	30	93	63
120	120	125	2311	132	30	93	63
120	120	125	2343	132	30	93	63
120	120	125	2767	132	30	93	63
140	120	125	2311	152	30	93	63
140	120	125	2343	152	30	93	63
140	120	125	2767	152	30	93	63
160	120	125	2311	172	30	93	63
160	120	125	2343	172	30	93	63
160	120	125	2767	172	30	93	63
180	120	125	2311	192	30	93	63
180	120	125	2343	192	30	93	63
180	120	125	2767	192	30	93	63

Großschieber in Sonderausführung

Schieber nach Kundenwunsch / Konstruktionsvorgabe.
Ausführungsvarianten und Materialien 1.2343, 1.2767,
1.2311 frei konfigurierbar.
Härten / Nitrieren auf Anfrage.

V = Verschraubung für Schieberaufsatz
K = Kühlbohrungen mit Kühlschluss Z7713
D = Druckplatte 1.2842
S = Schieberaufsatz 1.2343, 1.2767, 1.2311

Large slides in special design

Slider according to customer requirements / design
specifications. Variants and materials 1.2343, 1.2767,
1.2311 freely configurable.
Hardening / nitriding on request.

V = Screwing for slide attachment
K = Cooling holes with cooling connection Z7713
D = Pressure plate 1.2842
S = Slider attachment 1.2343, 1.2767, 1.2311

Coulisseaux de grande dimension au design spécial

Tiroir selon les exigences du client / spécifications de
conception. Variantes et matériaux 1.2343, 1.2767,
1.2311 librement configurable.
Durcissement / nituration sur demande.

V = Raccord à vis pour fixation de tiroir
K = Trous de refroidissement avec raccord de
refroidissement Z7713
D = Plaque de pression 1.2842
S = Fixation de tiroir 1.2343, 1.2767, 1.2311

5

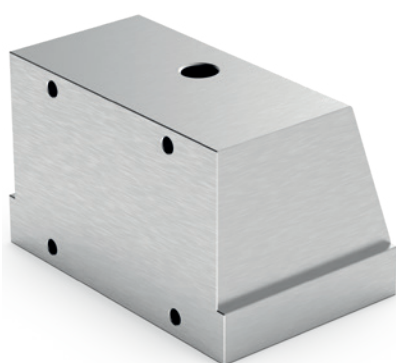

V	<input checked="" type="checkbox"/>	Type 15
K	<input type="checkbox"/>	
D	<input type="checkbox"/>	
S	<input type="checkbox"/>	

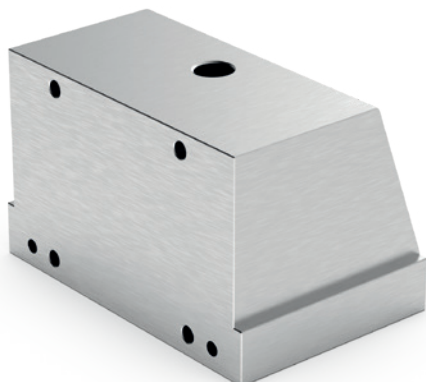

V	<input checked="" type="checkbox"/>	Type 20
K	<input checked="" type="checkbox"/>	
D	<input type="checkbox"/>	
S	<input type="checkbox"/>	

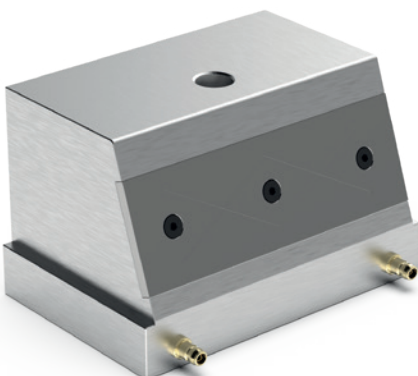
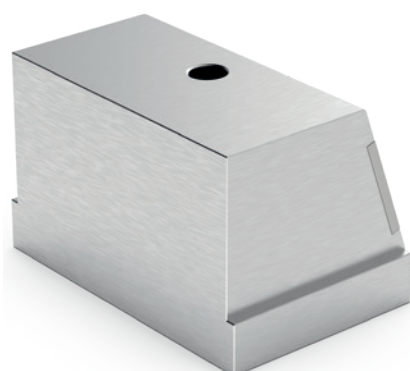

V	<input type="checkbox"/>	Type 25
K	<input checked="" type="checkbox"/>	
D	<input checked="" type="checkbox"/>	
S	<input type="checkbox"/>	

D 3002A 05.2022

Großschieber in Sonderausführung

Large slides in special design

Coulisseaux de grande dimension au design spécial

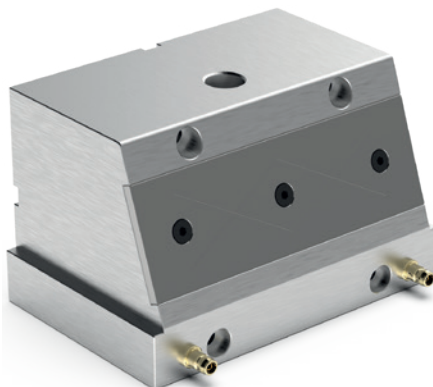

V	•	Type 30
K	•	
D	•	
S		

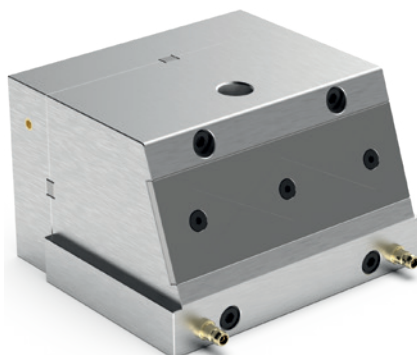

V	•	Type 35
K	•	
D	•	
S	•	

5

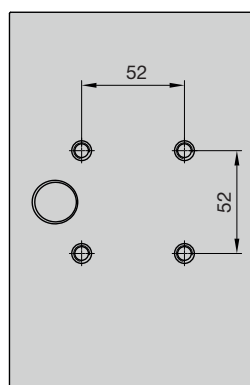
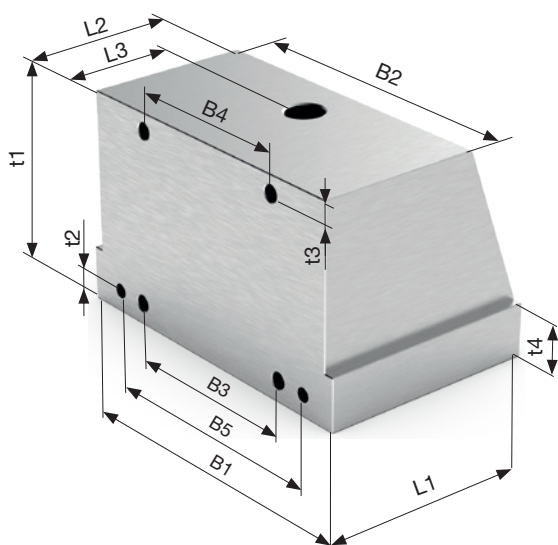

Alle Schieber haben auf der Unterseite Stich-Maß Bohrungen für Null-Punkt Spannsysteme.

All sliders have stitch gauges for boreholes on the underside for zero-point clamping systems.

Tous les tiroirs ont sur leur face inférieure perçages d'entraxe pour les systèmes de serrage à zero point.

Bestellschlüssel / Order code / Code de commande: Z421XX-B2-t1-L1-B1-t4-L2-L3-t2-t3-B3-B4-B5-Material
XX = Type

Schieberbaukästen

Slide construction kits

Bloc-éléments de tiroirs

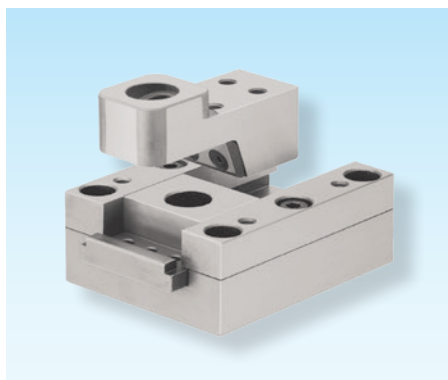

Z4200-

Mat.: ST



Z4200-B1-t1-L1



5

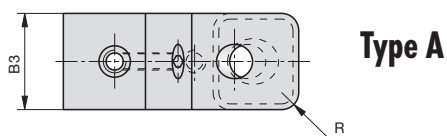

Type A

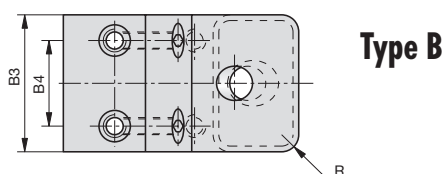

Type B

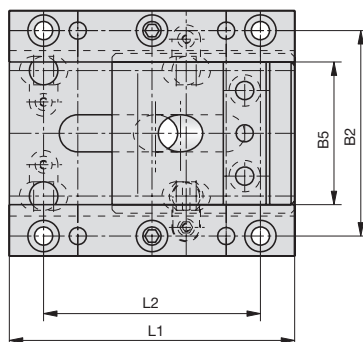
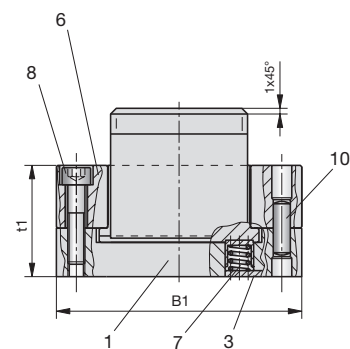
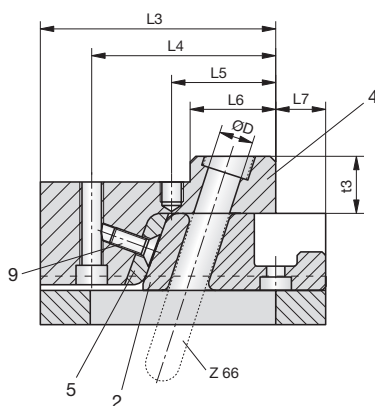

Pos. Item Pos.	STRACK NORM STRACK NORM NORME STRACK	Stück Qty. Nbr.	Bemerkung Remarks Observations
1	Z4205-B1-t1-L1	1	
2	Z4210-B2-t1-L1	1	
3	Z4211-Type	2	
4	Z4220-B1-t1-L1	1	
5	Z4230-B1-t1-S1	1	
6	Z4240-B1-t1-L1	2	
7	Z5134-D2	1	$t_i \leq 42$ / Z5134-7 $t_i > 42$ / Z5134-10
8	SN3500-d-L	2	
9	SN3550-d-L	1/2	
10	SN1973-d-L	4	

Toleranzen und fehlende Angaben siehe Einzelteile

See individual parts for tolerances and missing data

Tolérances et indications manquantes voir pièces détachées

B1	t1	L1	Type	B2	B3	B4	B5	t2	t3	L2	L3	L4	L5	L6	L7	D	D2	D5	D6	R
50	28	75	A	38	18	-	20	11	20	60	65,0	50	26,0	20	10,0	8	M6	M5	M5	5
55	28	75	A	43	23	-	25	11	20	60	65,0	50	26,0	20	10,0	10	M6	M5	M5	5
60	28	75	B	48	28	14	30	11	20	60	70,0	57	36,0	30	5,0	12	M6	M5	M5	6
70	28	75	B	58	38	22	40	11	20	60	70,0	57	36,0	30	5,0	12	M6	M5	M5	6
80	28	75	B	68	48	32	50	11	20	60	70,0	57	36,0	30	5,0	12	M6	M5	M5	6
90	28	75	B	78	58	42	60	11	20	60	70,0	57	36,0	30	5,0	12	M6	M5	M5	6
60	28	90	B	48	28	14	30	11	20	70	70,0	57	36,0	30	5,0	12	M6	M5	M5	6
70	28	90	B	58	38	22	40	11	20	70	70,0	57	36,0	30	5,0	12	M6	M5	M5	6
80	28	90	B	68	48	32	50	11	20	70	70,0	57	36,0	30	5,0	12	M6	M5	M5	6
76	42	100	B	62	38	18	40	11	20	76	82,5	65	36,5	30	17,5	12	M8	M6	M6	6
86	42	100	B	72	48	28	50	11	20	76	82,5	65	36,5	30	17,5	12	M8	M6	M6	6
96	42	100	B	82	58	38	60	11	20	76	82,5	65	36,5	30	17,5	12	M8	M6	M6	6

Stückliste
Parts list
Liste des pièces

Z4200-	Z4205- (1x)	Z4210- (1x)	Z4220- (1x)	Z4230- (1x)	Z4240- (2x)	Z5134- (1x)	Z4211- (2x)
50 - 28 - 75	50 - 17 - 75	20 - 16 - 40	18 - 15 - 65	18 - 15 - 4	15 - 11 - 75	7	1
55 - 28 - 75	55 - 17 - 75	25 - 16 - 40	23 - 15 - 65	23 - 15 - 4	15 - 11 - 75	7	1
60 - 28 - 75	60 - 17 - 75	30 - 16 - 45	28 - 15 - 70	28 - 15 - 4	15 - 11 - 75	7	1
70 - 28 - 75	70 - 17 - 75	40 - 16 - 45	38 - 15 - 70	38 - 15 - 4	15 - 11 - 75	7	1
80 - 28 - 75	80 - 17 - 75	50 - 16 - 45	48 - 15 - 70	48 - 15 - 4	15 - 11 - 75	7	1
90 - 28 - 75	90 - 17 - 75	60 - 16 - 45	58 - 15 - 70	58 - 15 - 4	15 - 11 - 75	7	1
60 - 28 - 90	60 - 17 - 90	30 - 16 - 45	28 - 15 - 70	28 - 15 - 4	15 - 11 - 90	7	1
70 - 28 - 90	70 - 17 - 90	40 - 16 - 45	38 - 15 - 70	38 - 15 - 4	15 - 11 - 90	7	1
80 - 28 - 90	80 - 17 - 90	50 - 16 - 45	48 - 15 - 70	48 - 15 - 4	15 - 11 - 90	7	1
76 - 42 - 100	76 - 20 - 100	40 - 30 - 64	38 - 29 - 82,5	38 - 29 - 6	18 - 22 - 100	7	1
86 - 42 - 100	86 - 20 - 100	50 - 30 - 64	48 - 29 - 82,5	48 - 29 - 6	18 - 22 - 100	7	1
96 - 42 - 100	96 - 20 - 100	60 - 30 - 64	58 - 29 - 82,5	58 - 29 - 6	18 - 22 - 100	7	1

Einbauvariante 1

Installation variant 1

Variante de montage 1

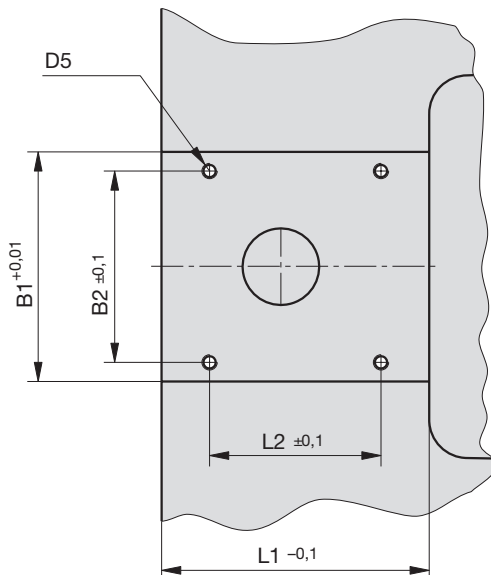
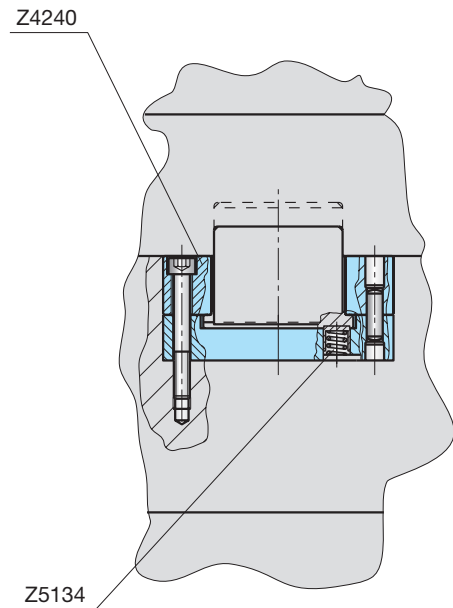
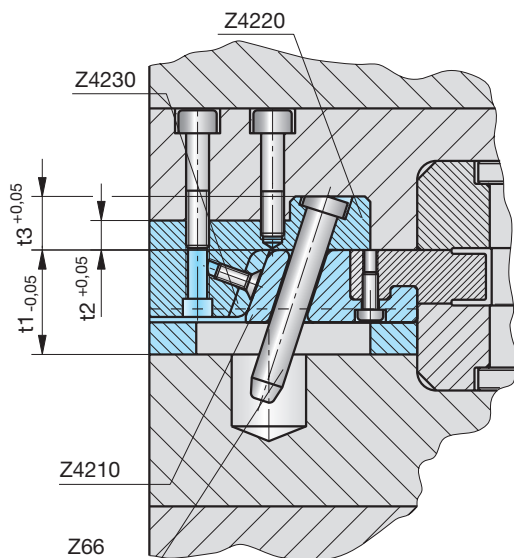
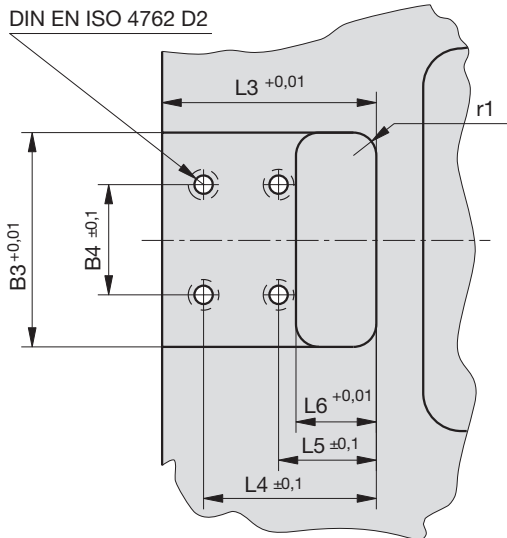

Einbauvariante 2

Installation variant 2

Variante de montage 2

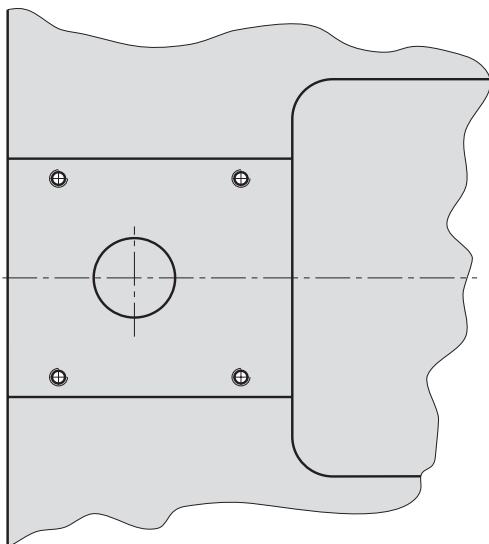
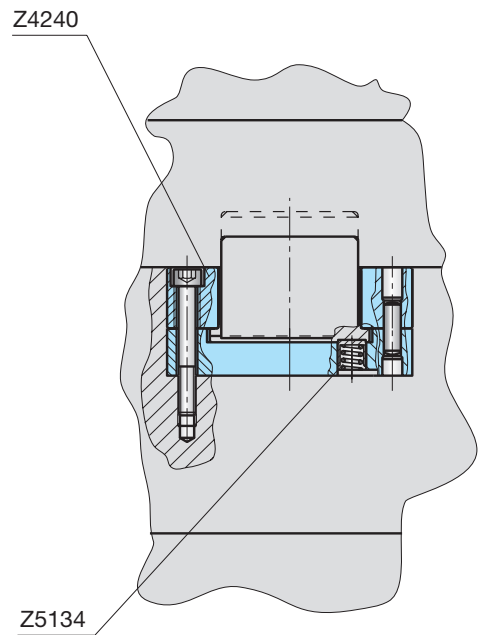
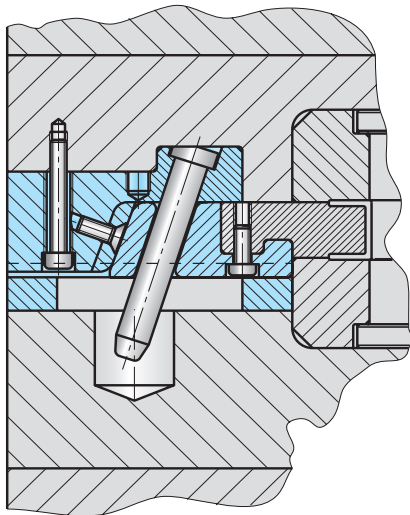
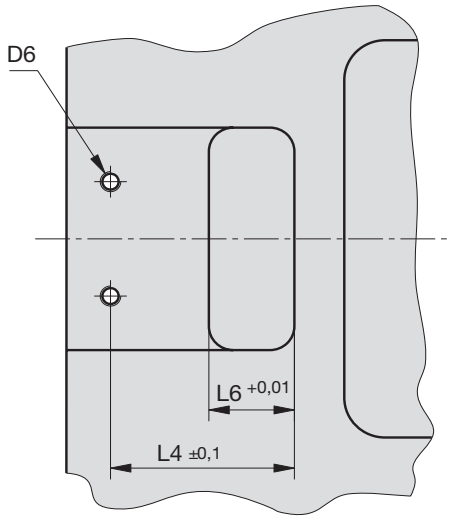

Schieberkästen

Slide casings

Boîte à tiroirs

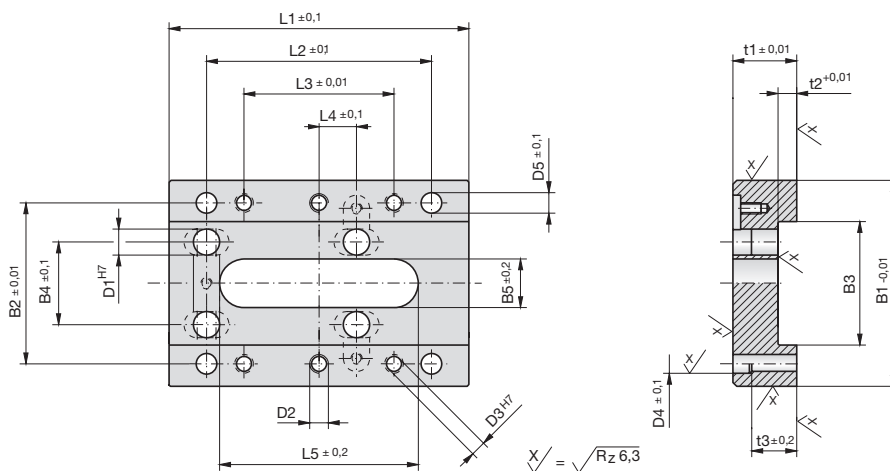
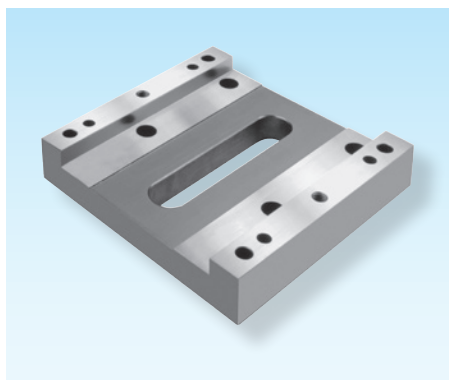

Z4205-

Mat.: ST
58 +2HRC



Z4205-B1-t1-L1



5

B1	t1	L1	B2	B3	B4	B5	t2	t3	L2	L3	L4	L5	D1	D2	D3	D4	D5
50	17	75	38	26	18	9	5	12	60	40	10	51	7	M5	4	5	5,5
55	17	75	43	31	21	11	5	12	60	40	10	51	7	M5	4	5	5,5
60	17	75	48	36	25	13	5	12	60	40	10	51	7	M5	4	5	5,5
70	17	75	58	46	32	13	5	12	60	40	10	51	7	M5	4	5	5,5
80	17	75	68	56	42	13	5	12	60	40	10	51	7	M5	4	5	5,5
90	17	75	78	66	52	13	5	12	60	40	10	51	7	M5	4	5	5,5
60	17	90	48	36	25	13	5	12	70	50	10	61	7	M5	4	5	5,5
70	17	90	58	46	32	13	5	12	70	50	10	61	7	M5	4	5	5,5
80	17	90	68	56	42	13	5	12	70	50	10	61	7	M5	4	5	5,5

Schieber

Slides

Tiroirs

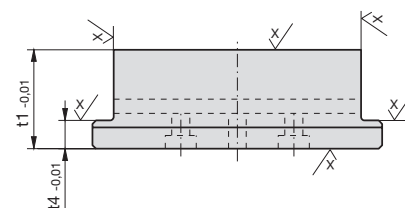
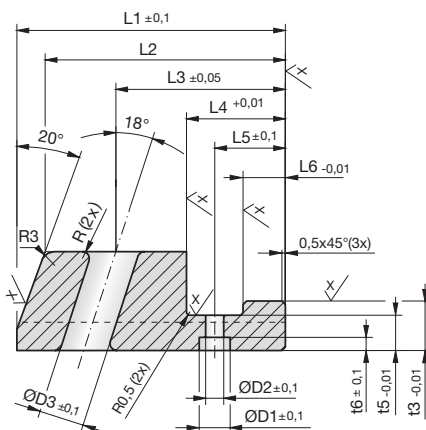

Z4210-

Mat.: ST
52 +2HRC



Z4210-B2-t1-L1

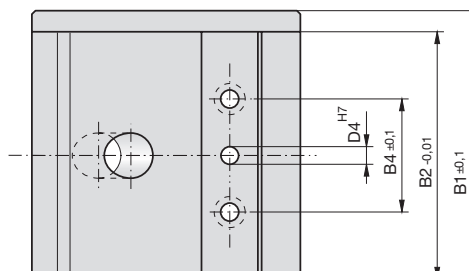

$$\sqrt{\text{X}} = \sqrt{R_z 6,3}$$

Nitriert ca. 70 HRC, max. 0,1 mm
Nitrided, approx. 70 HRC, 0.1 mm max.
Nitrué, env. 70 HRC, 0,1 mm max.

B2	t1	L1	B1	B3	B4	t2	t3	t4	t5	t6	L2	L3	L4	L5	L6	D1	D2	D3	D4	R
20	16	40	25	-	13	-	8	5	5	2,4	35	24	15	10	5	6	3,2	9	3	1,5
25	16	40	30	-	15	-	8	5	5	3,2	35	24	15	10	5	8	4,3	11	4	1,5
30	16	45	35	-	18	-	8	5	5	3,2	40	26	15	10	5	8	4,3	13	4	1,5
40	16	45	45	-	25	-	8	5	5	3,2	40	26	15	10	5	8	4,3	13	4	1,5
50	16	45	55	-	30	-	8	5	5	3,2	40	26	15	10	5	8	4,3	13	4	1,5
60	16	45	65	-	40	-	8	5	5	3,2	40	26	15	10	5	8	4,3	13	4	1,5

2K Schiebereinheit

2K slider unit

2K unité de tiroir



Z42900-

Z42900-B1-t1-
Mat



5

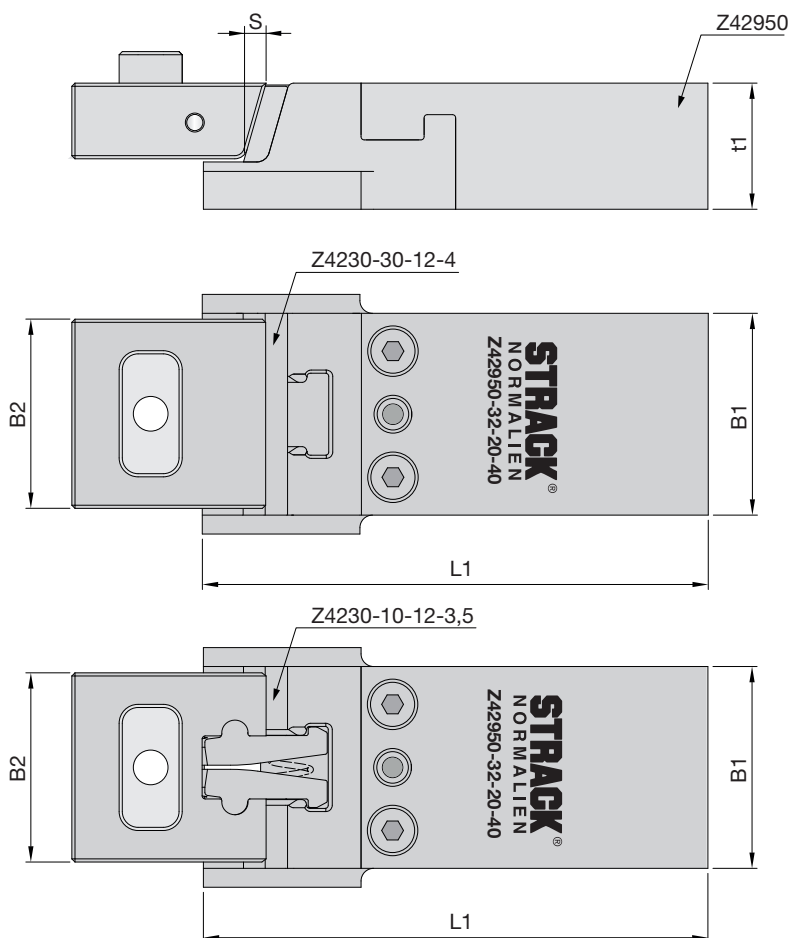

B1	t1	Mat	L1	B2	S
32	20	2343	80	30	3
32	20	2767	80	30	3

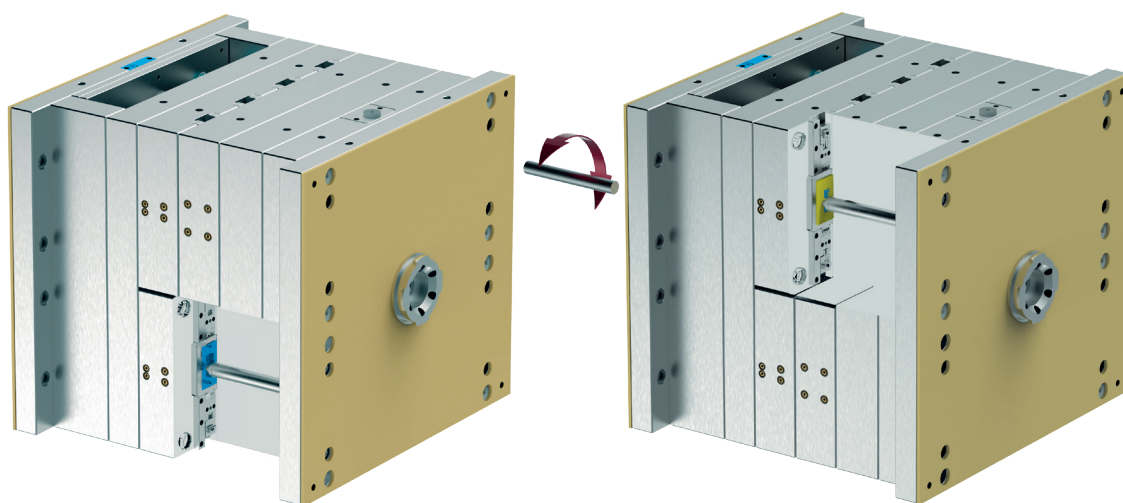

Spritzgießen der Komponente 1.
Injection moulding of component 1.
Moulage par injection du composant 1.

Drehen des Werkzeuges in Position 2.
Turning the tool to position 2.
Tourner l'outil en position 2.

Spritzgießen der Komponente 2.
Injection moulding of component 2.
Moulage par injection du composant 2.

2K Schiebereinheit

Erster Schieber, der Hinterschnitte bei Zweikomponentenspritzgussteilen freistellt.

- Schieber wird in vordere Position gebracht und verriegelt den Schieber beim Spritzen der ersten Komponente. Schieber bleibt in vorderer Position stehen, um den Artikel nicht zu beschädigen.
- Nach drehen des Werkzeuges verriegelt das zweite Druckstück (mit Klinken) den Schieber zum Spritzen der zweiten Komponente. Beim Öffnen des Werkzeuges zieht das Druckstück den Schieber wieder in die Ausgangsstellung.

Beispiel 2K Spritzgussteil mit Hinterschnitt

2K slider unit

The first slide which releases undercuts in two-component injection moulding parts.

- The slide is brought into front position and locks the slide when injecting the first component. The slide remains in front position in order not to damage the item.
- After turning the tool, the second pressure piece (with latches) locks the slide for injecting the second component. When the tool is opened, the pressure piece pulls the slide back into the initial position.

Example 2K injection moulding part with undercut

2K unité de tiroir

Premier tiroir pour libérer des contre-dépouilles aux pièces moulées par injection à deux composants.

- Le tiroir est amené à la position avant et verrouille le tiroir lors de l'injection du premier composant. Le tiroir reste en position avant afin de ne pas endommager l'article.
- Après avoir tourné l'outil, la seconde pièce de pression verrouille le tiroir pour l'injection du deuxième composant. Lors de l'ouverture de l'outil la pièce de pression tire le tiroir dans la position initiale.

Exemple de pièce moulée par injection 2K avec contre-dépouille

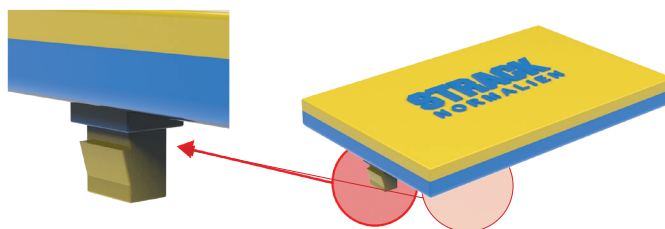

Schieber in vorderer Position und verriegelt, Komponente 1 wird gespritzt.

Slider in front position and locked, component 1 is injected.

Tiroir en position avant et verrouillé, composant 1 est injecté.

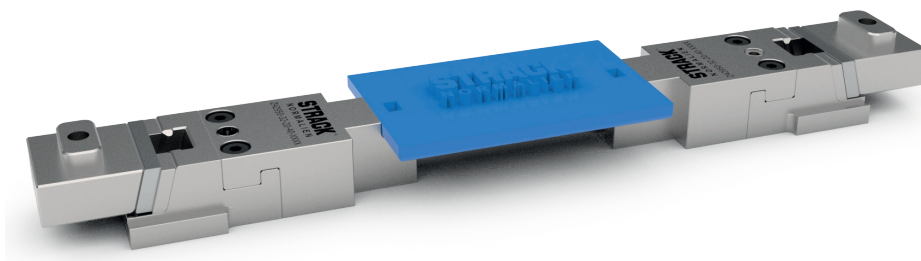

Schieber bleibt in vorderer Position, Werkzeug dreht in Spritzposition 2, Komponente 2 wird gespritzt.

Slider remains in front position, tool rotates in injection position 2, component 2 is injected.

Le tiroir reste en position avant, l'outil tourne en position d'injection 2, le composant 2 est injecté.

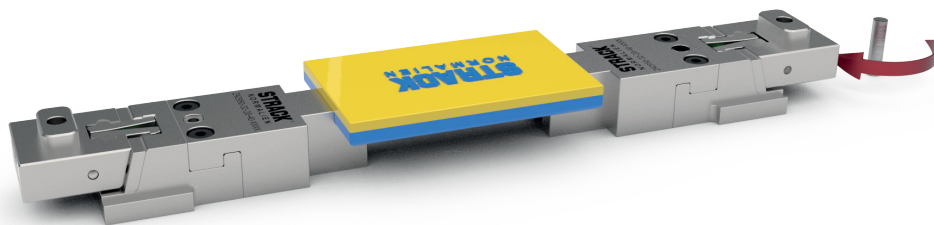

Werkzeug öffnet, Schieber wird zurückgezogen, 2K Teil ist entformt.

Tools opens, slider is retracted, 2K part is demoulded.

L'outil s'ouvre, le tiroir est rétracté, la pièce 2K est démoulée.

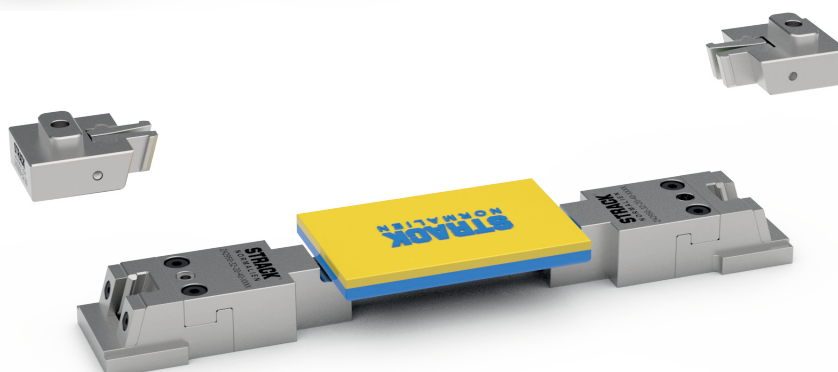

Schieberaufsatz

Slider attachment

Rehausse de coulisseau

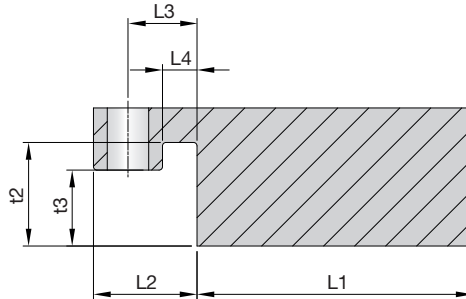
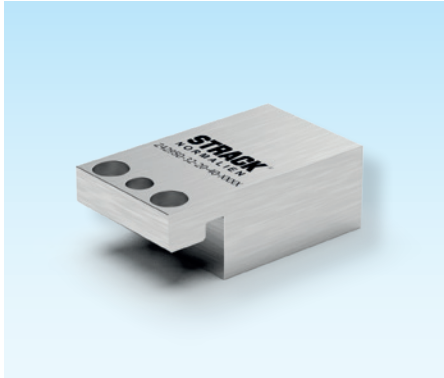

Z42950-

52+2HRC

Z42950-B1-t1-
L1-Mat



5

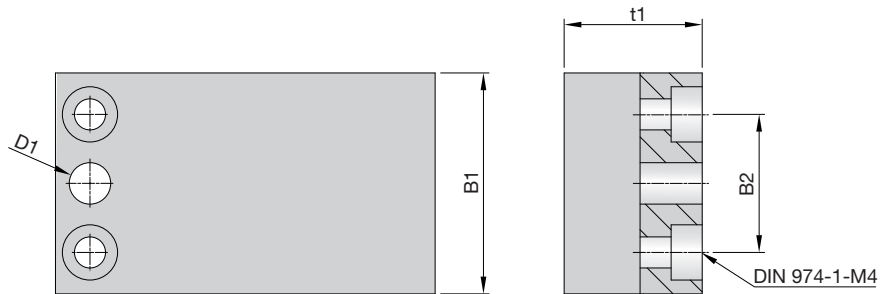

B1	t1	L1	Mat	B2	L2	L3	t2	t3	D1	L4
32	20	40	2343	20	15	10	15	11	6	5
32	20	40	2767	20	15	10	15	11	6	5

Halteplatten

Fixing plates

Plaquettes de fixation

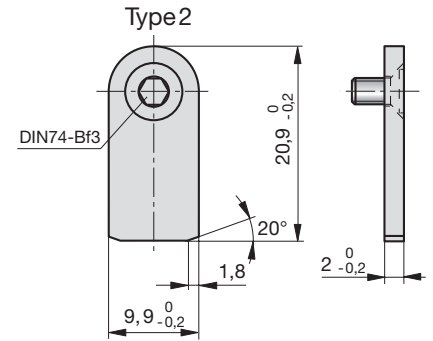
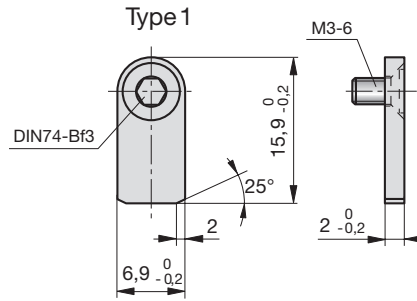
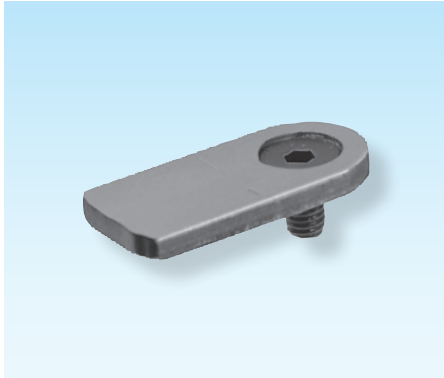

Z4211-

Type

1

2



Z4211-Type



Druckstücke mit Schrägsäulenaufnahme

Locking heels, double sided

Coins de fermeture avec support de colonne oblique



Z4220-

Mat.: ST
60 +2HRC

Z4220-B1-t1-L1



5

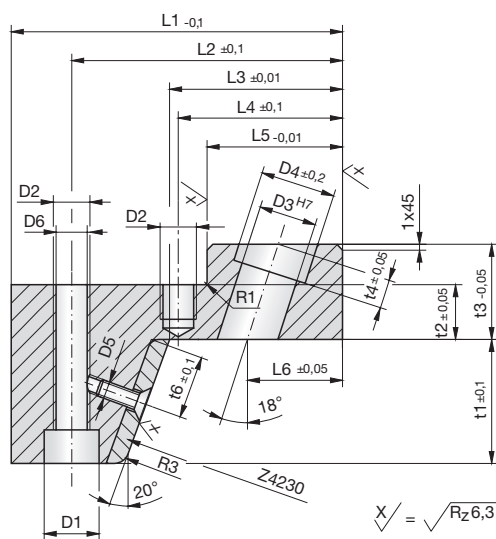

Type A

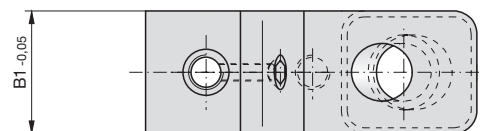

Type B

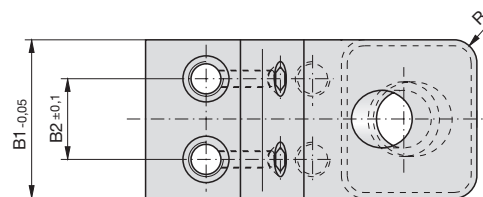

B1	t1	L1	Type	B2	t2	t3	t4	t6	L2	L3	L4	L5	L6	D1	D2	D3	D4	D5	D6	R
18	15	65	A	–	11	20	3	8	50	25,0	26,0	20	14,0	10	M6	8	11,5	M4	5,3	5
23	15	65	A	–	11	20	4	8	50	25,0	26,0	20	14,0	10	M6	10	14,5	M4	5,3	5
28	15	70	B	14	11	20	6	8	57	35,0	36,0	30	21,0	10	M6	12	17,0	M4	5,3	6
38	15	70	B	22	11	20	6	8	57	35,0	36,0	30	21,0	10	M6	12	17,0	M4	5,3	6
48	15	70	B	32	11	20	6	8	57	35,0	36,0	30	21,0	10	M6	12	17,0	M4	5,3	6
58	15	70	B	42	11	20	6	8	57	35,0	36,0	30	21,0	10	M6	12	17,0	M4	5,3	6
38	29	82,5	B	18	11	20	6	15	65	37,5	36,5	30	22,5	11	M8	12	17,0	M6	6,4	6
48	29	82,5	B	28	11	20	6	15	65	37,5	36,5	30	22,5	11	M8	12	17,0	M6	6,4	6
58	29	82,5	B	38	11	20	6	15	65	37,5	36,5	30	22,5	11	M8	12	17,0	M6	6,4	6
78	29	95	B	44	14	25	8	15	73	46,0	49,0	42	28,0	15	M10	16	21,0	M6	8,4	8
98	29	95	B	64	14	25	8	15	73	46,0	49,0	42	28,0	15	M10	16	21,0	M6	8,4	8
35	45	115	A	–	19	33	10	22	94	60,0	59,0	47	33,0	18	M12	20	26,0	M6	10,4	8
55	45	115	B	28	19	33	10	22	94	60,0	59,0	47	33,0	18	M12	20	26,0	M6	10,4	8

Druckstücke

Locking heels

Coins de fermeture

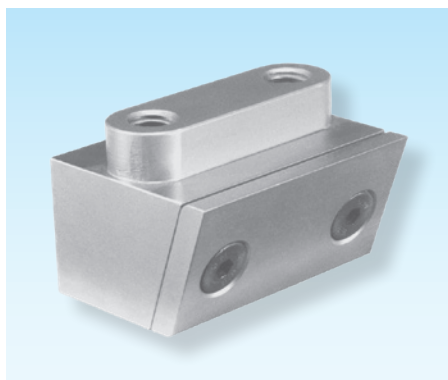

Z4222-

Mat.: ST
60 +2HRC



Z4222-B1-t1

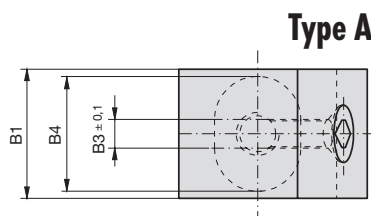

Type A

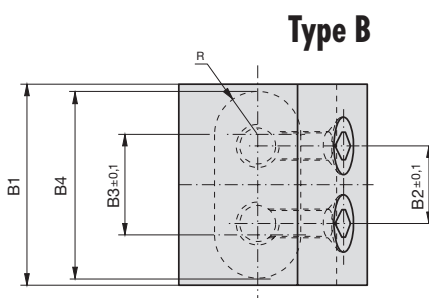

Type B

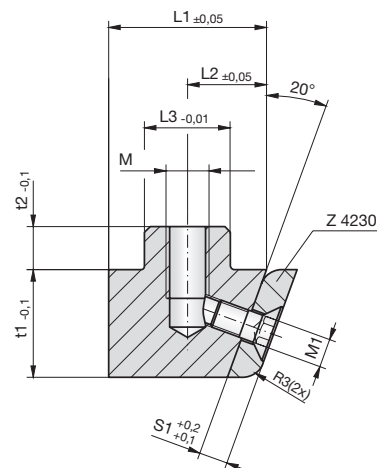

B1	t1	Type	B2	B3	t2	t6	L1	L2	L3	M	M1	S1	B4	R
18	15	A	–	4	6	8	22,0	11,0	12	M6	M6	4	16	6
23	15	A	–	9	6	8	22,0	11,0	12	M6	M6	4	21	6
28	15	B	14	14	6	8	22,0	11,0	12	M6	M4	4	26	6
38	15	B	22	22	6	8	22,0	11,0	12	M6	M4	4	34	6
48	15	B	32	32	6	8	22,0	11,0	12	M6	M4	4	44	6
58	15	B	42	42	6	8	22,0	11,0	12	M6	M4	4	54	6
38	29	B	18	18	10	15	38,6	18,6	18	M10	M6	6	36	9
48	29	B	28	28	10	15	38,6	18,6	18	M10	M6	6	46	9
58	29	B	38	38	10	15	38,6	18,6	18	M10	M6	6	56	9
78	29	B	44	58	10	15	38,6	18,6	18	M10	M6	6	76	9
98	29	B	64	78	10	15	38,6	18,6	18	M10	M6	6	96	9
35	45	A	–	13	12	22	48,6	21,6	20	M10	M6	6	33	10
55	45	B	28	28	12	22	48,6	21,6	20	M10	M6	6	48	10
78	45	B	50	50	12	22	48,6	21,6	20	M10	M6	6	70	10
98	45	B	70	70	12	22	48,6	21,6	20	M10	M6	6	90	10

Druckplatten

Pressure plates

Plaques de pression

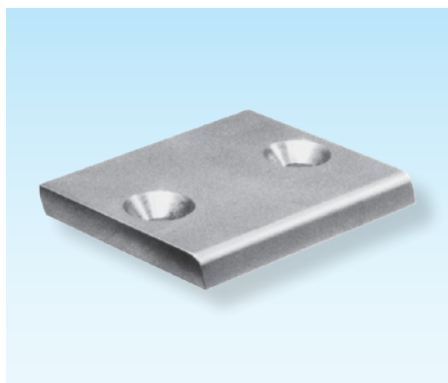

Z4230-

Mat.: ST
60+2HRC



Z4230-B1-t1-S1



5

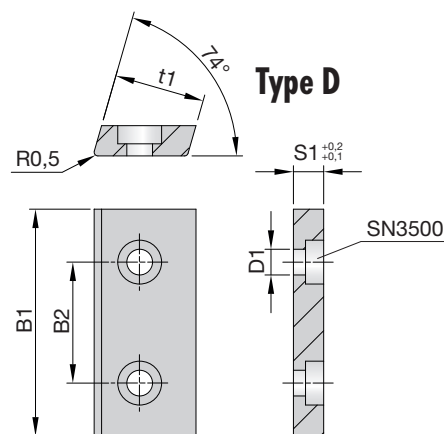
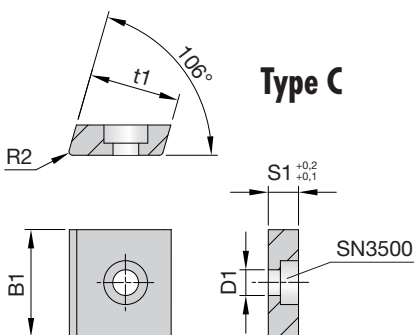
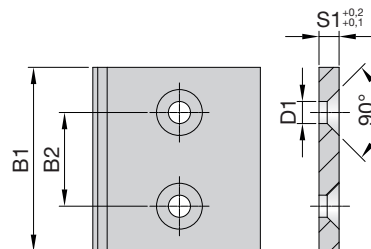
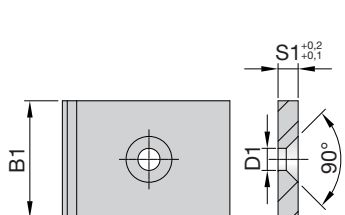
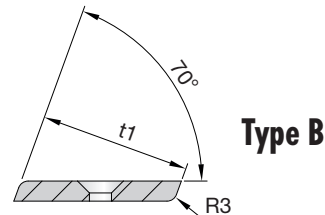
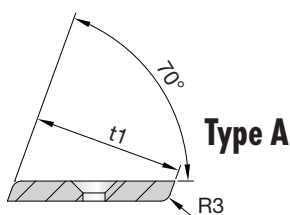

B1	t1	S1	Type	B2	D1
10	12	3,5	C	–	3,5
18	15	4	A	–	4,5
23	15	4	A	–	4,5
28	15	4	B	14	4,5
30	12	4	D	16	3,5
38	15	4	B	22	4,5
48	15	4	B	32	4,5
58	15	4	B	42	4,5
38	29	6	B	18	6,6
48	29	6	B	28	6,6
58	29	6	B	38	6,6
78	29	6	B	44	6,6
98	29	6	B	64	6,6
35	45	6	A	–	6,6
55	45	6	B	28	6,6
78	45	6	B	50	6,6
98	45	6	B	70	6,6

Führungsleisten

Guide strips

Barres de guidage

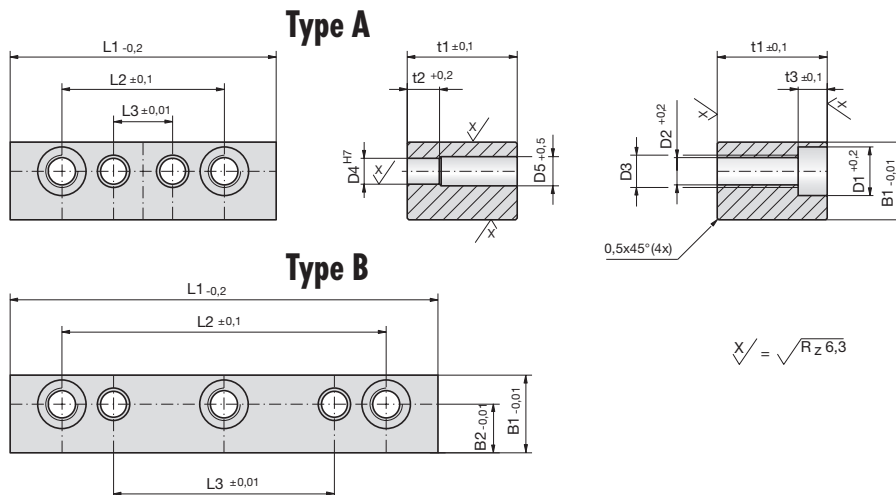

Z4240-

Mat.: ST
58 +2HRC



Z4240-B1-t1-L1



B1	t1	L1	Type	B2	t2	t3	L2	L3	D1	D2	D3	D4	D5
15	11	50	A	9	–	5,7	30	10	10	5,3	M6	4	–
15	11	60	A	9	–	5,7	40	20	10	5,3	M6	4	–
15	11	70	B	9	–	5,7	50	30	10	5,3	M6	4	–
15	11	75	B	9	–	5,7	60	40	10	5,3	M6	4	–
15	11	80	B	9	–	5,7	60	40	10	5,3	M6	4	–
15	11	90	B	9	–	5,7	70	50	10	5,3	M6	4	–
18	22	80	A	11	12	6,8	56	32	11	6,4	M8	6	7
18	22	100	B	11	12	6,8	76	52	11	6,4	M8	6	7
18	22	120	B	11	12	6,8	96	72	11	6,4	M8	6	7
18	22	140	B	11	12	6,8	116	92	11	6,4	M8	6	7
18	22	160	B	11	12	6,8	136	112	11	6,4	M8	6	7
24	36	100	A	15	12	9,0	68	36	15	8,5	M10	8	9
24	36	120	A	15	12	9,0	88	56	15	8,5	M10	8	9
24	36	140	B	15	12	9,0	108	76	15	8,5	M10	8	9
24	36	160	B	15	12	9,0	128	96	15	8,5	M10	8	9
24	36	180	B	15	12	9,0	148	116	15	8,5	M10	8	9
30	50	120	A	18	18	11,0	80	40	18	10,5	M12	10	11
30	50	140	A	18	18	11,0	100	60	18	10,5	M12	10	11
30	50	160	B	18	18	11,0	120	80	18	10,5	M12	10	11
30	50	180	B	18	18	11,0	140	100	18	10,5	M12	10	11
30	50	200	B	18	18	11,0	160	120	18	10,5	M12	10	11
36	63	140	A	22	18	13,0	92	44	20	12,5	M14	12	13
36	63	160	A	22	18	13,0	112	64	20	12,5	M14	12	13
36	63	180	B	22	18	13,0	132	84	20	12,5	M14	12	13
36	63	200	B	22	18	13,0	152	104	20	12,5	M14	12	13
36	63	220	B	22	18	13,0	172	124	20	12,5	M14	12	13

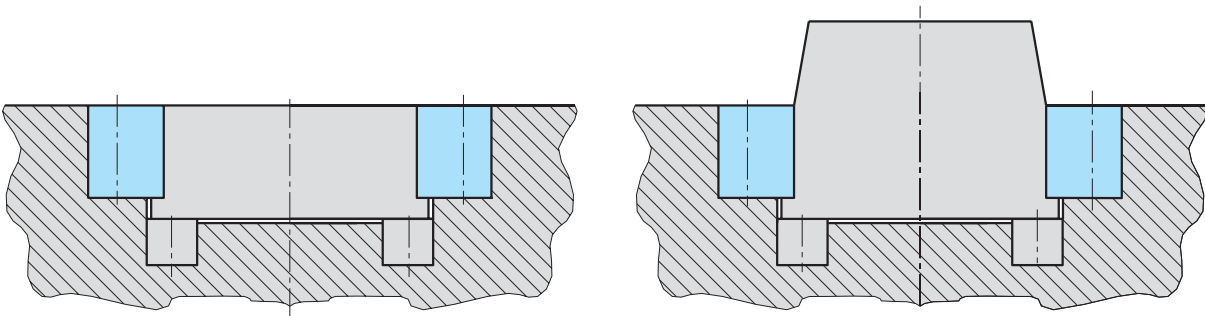
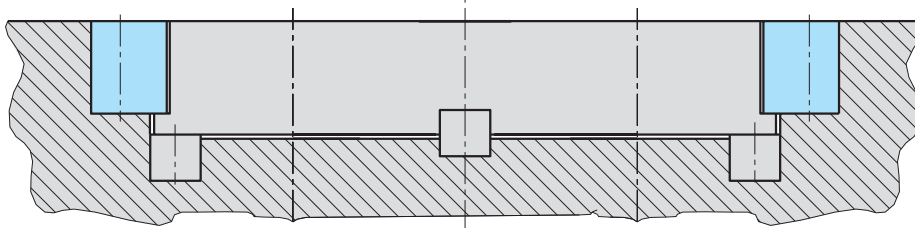
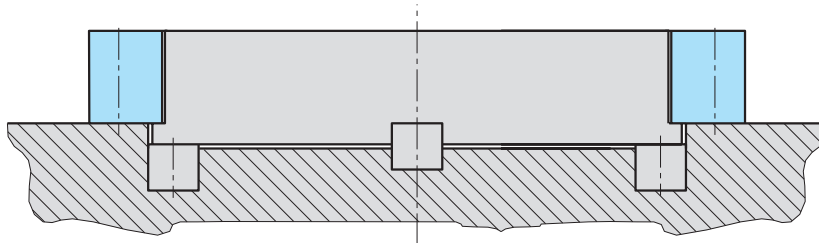
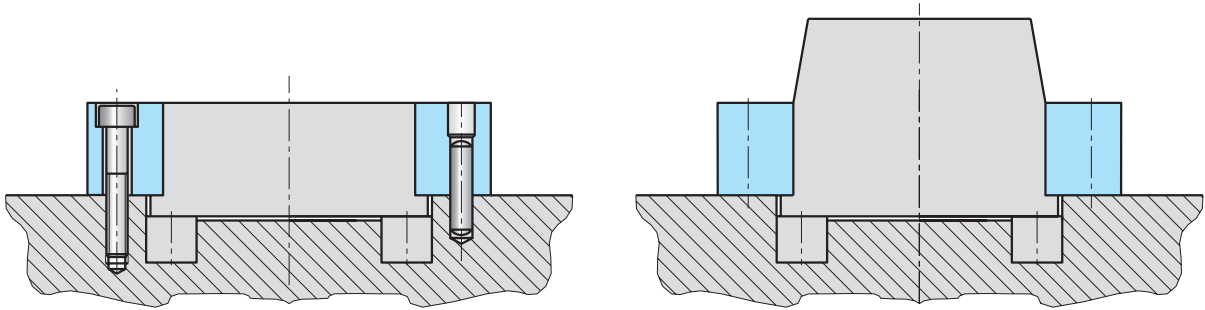

5

Produktübersicht

Product range

Presentation des produits

Z4165/ Z4166

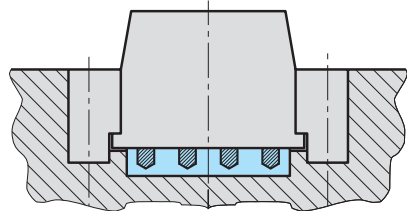

Z4240

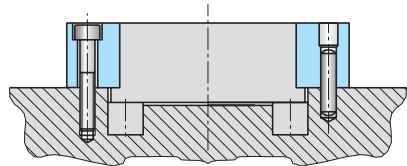

5

Z4242

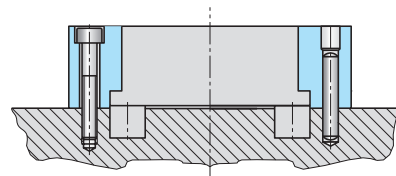
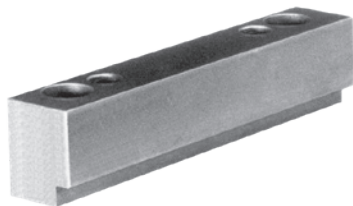

Z4244

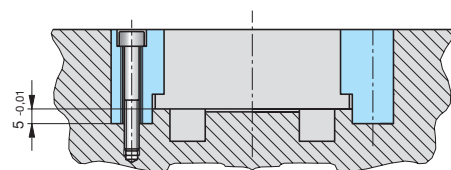
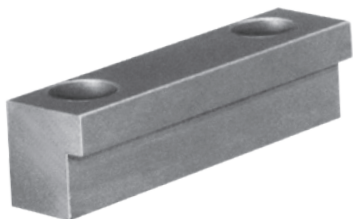

Z4248

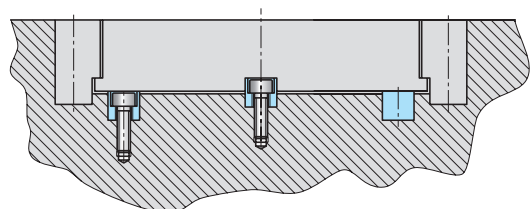
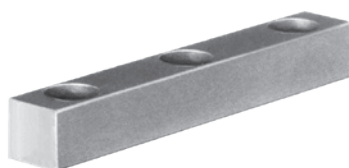

Flachführungsleisten, selbstschmierend

Flat guide strips, self-lubricating

Barres de guidage plate, autolubrifiantes

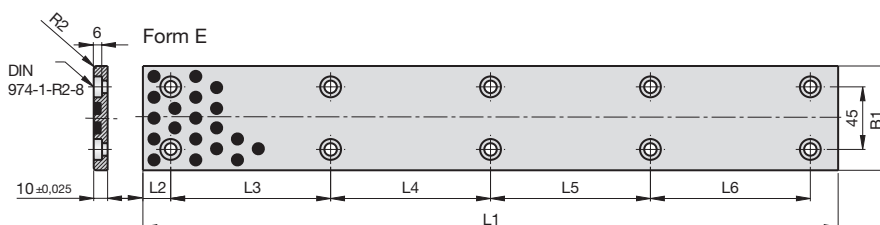
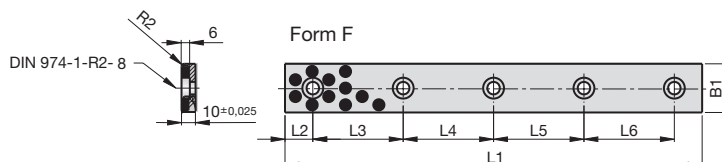
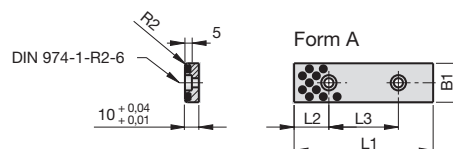

Z4165-

Mat.: Bronze
190-220 HB S10/3000
< 150 °C



Z4165-B1-L1

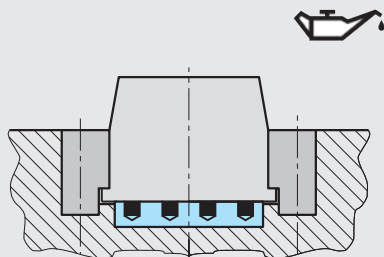

5

B1	L1	Form	L2	L3	L4	L5	L6	DIN 974-1-R2-	Bohrungen Drillings Perçages
18	75	A	15	45	-	-	-	6	2
18	100	A	25	50	-	-	-	6	2
18	125	A	25	75	-	-	-	6	2
18	150	A	25	100	-	-	-	6	2
28	75	A	15	45	-	-	-	6	2
28	100	A	25	50	-	-	-	6	2
28	125	A	25	75	-	-	-	6	2
28	150	A	25	100	-	-	-	6	2
35	100	F	20	60	-	-	-	8	2
35	150	F	20	55	55	-	-	8	3
35	200	F	20	55	50	55	-	8	4
35	250	F	20	70	70	70	-	8	4
35	300	F	20	65	65	65	65	8	5
35	350	F	20	80	75	75	80	8	5
38	75	A	15	45	-	-	-	6	2
38	100	A	25	50	-	-	-	6	2
38	125	A	25	75	-	-	-	6	2
38	150	A	25	100	-	-	-	6	2
48	75	A	15	45	-	-	-	6	2
48	100	A	25	50	-	-	-	6	2
48	125	A	25	75	-	-	-	6	2
48	150	A	25	100	-	-	-	6	2

Flachführungsleisten, selbstschmierend

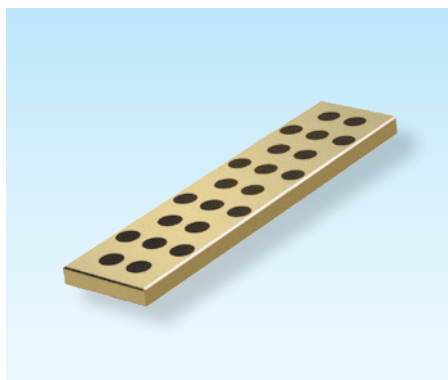

Flat guide strips, self-lubricating

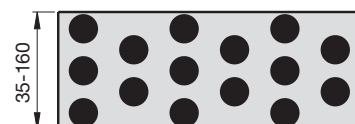
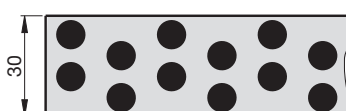
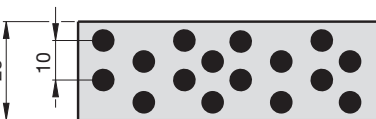
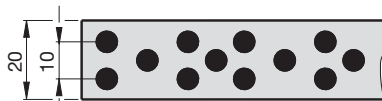

Z4166-

Mat.: Bronze
190-220 HB S10/3000
< 150 °C



Z4166-B1-H-L1



5

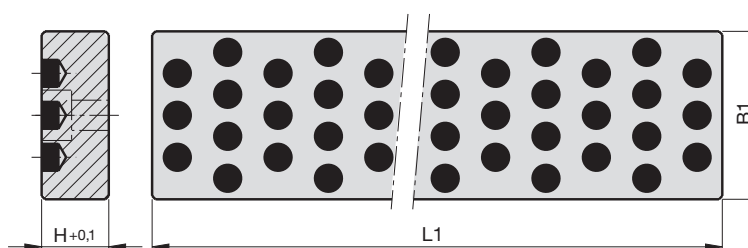
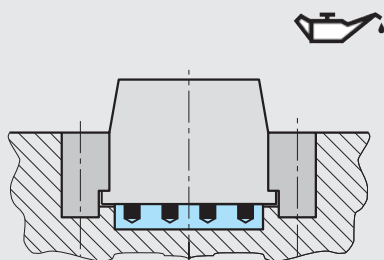

B1	H	L1	B1	H	L1
20	4	305 ±0,8	60	12	315 ⁻²
30	4		80	12	375 ⁻²
25	5		40	16	630 ⁻²
40	5	605 ±0,8	60	16	1005 ±0,8
30	6		80	16	
40	6		100	16	
30	8	315 ⁻²	50	20	1005 ±0,8
40	8		80	20	
30	10		100	20	
35	10	375 ⁻²	125	20	1005 ±0,8
40	10	630 ⁻²	160	20	
50	10	1005 ±0,8	80	25	
80	10	1005 ±0,8	100	25	1005 ±0,8
30	12		125	25	
40	12		160	25	
50	12				

Führungsleisten

Guide strips

Barres de guidage

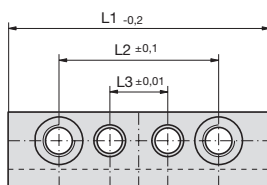
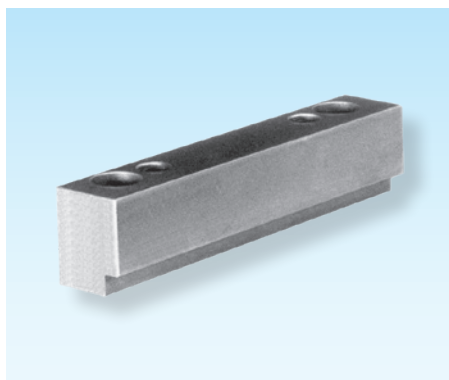

Type A

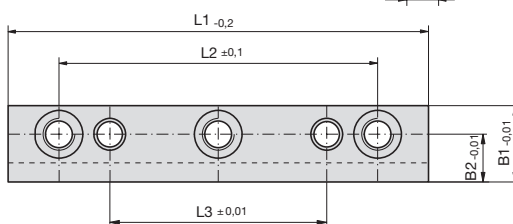
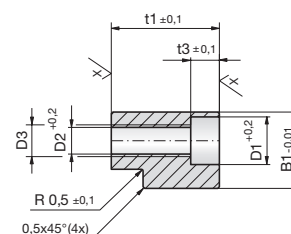
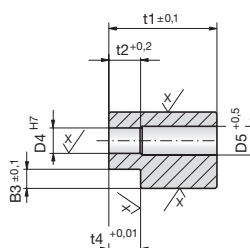

Type B

$$X/\sqrt{Rz} = \sqrt{Rz} 6,3$$

Z4242-

Mat.: ST
58 +2HRC



Z4242-B1-t1-L1



B1	t1	L1	Type	B2	B3	t2	t3	t4	L2	L3	D1	D2	D3	D4	D5
15	16	50	A	9	3	–	5,7	5	30	10	10	5,3	M6	4	–
15	16	60	A	9	3	–	5,7	5	40	20	10	5,3	M6	4	–
15	16	70	B	9	3	–	5,7	5	50	30	10	5,3	M6	4	–
15	16	75	B	9	3	–	5,7	5	60	40	10	5,3	M6	4	–
15	16	80	B	9	3	–	5,7	5	60	40	10	5,3	M6	4	–
15	16	90	B	9	3	–	5,7	5	70	50	10	5,3	M6	4	–
18	30	80	A	11	4	12	6,8	8	56	32	11	6,8	M8	6	7
18	30	100	A	11	4	12	6,8	8	76	52	11	6,8	M8	6	7
18	30	120	B	11	4	12	6,8	8	96	72	11	6,8	M8	6	7
18	30	140	B	11	4	12	6,8	8	116	92	11	6,8	M8	6	7
18	30	160	B	11	4	12	6,8	8	136	112	11	6,8	M8	6	7
24	46	100	A	15	6	12	9,0	10	68	36	15	8,5	M10	8	9
24	46	120	A	15	6	12	9,0	10	88	56	15	8,5	M10	8	9
24	46	140	B	15	6	12	9,0	10	108	76	15	8,5	M10	8	9
24	46	160	B	15	6	12	9,0	10	128	96	15	8,5	M10	8	9
24	46	180	B	15	6	12	9,0	10	148	116	15	8,5	M10	8	9



5

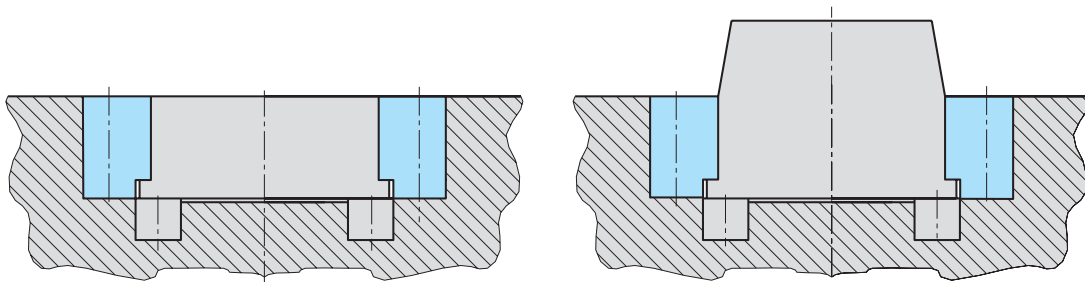
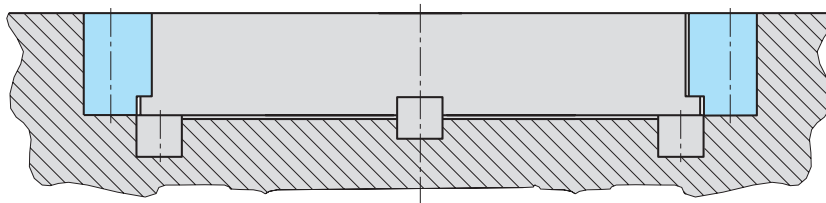
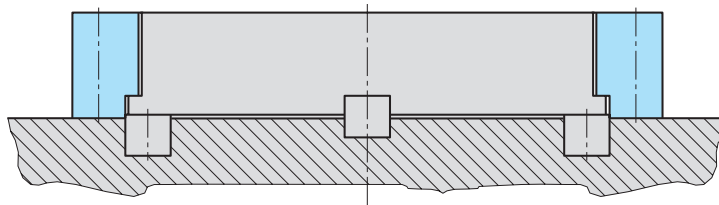
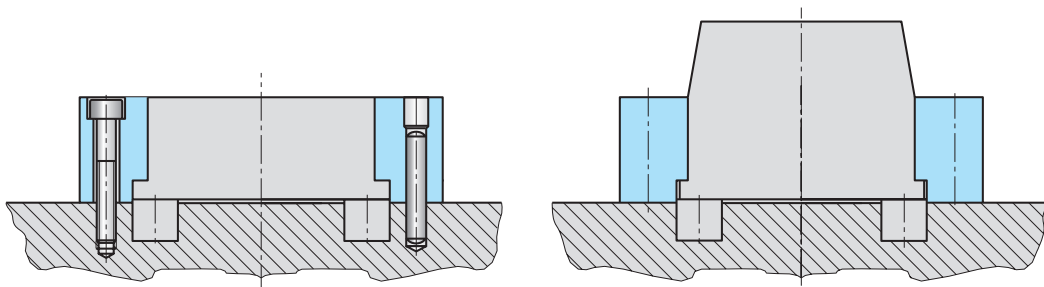

D 3002A 07.2018

Führungsleisten

Guide strips

Barres de guidage

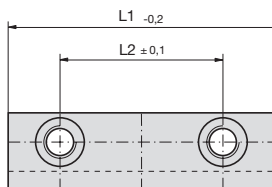

Type A

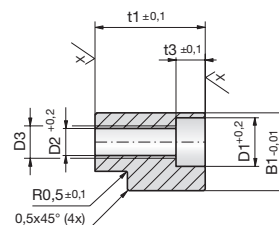
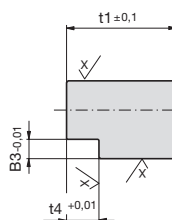

$$X/\sqrt{R} = \sqrt{z} 6,3$$

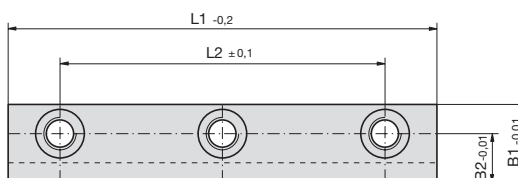

Type B

Z4244-

Mat.: ST
58 +2HRC



Z4244-B1-t1-L1



B1	t1	L1	Type	B2	B3	t3	t4	L2	D1	D2	D3
15	21	50	A	9	3	5,7	10	30	10	5,3	M6
15	21	60	A	9	3	5,7	10	40	10	5,3	M6
15	21	70	B	9	3	5,7	10	50	10	5,3	M6
15	21	75	B	9	3	5,7	10	60	10	5,3	M6
15	21	80	B	9	3	5,7	10	60	10	5,3	M6
15	21	90	B	9	3	5,7	10	70	10	5,3	M6
18	35	80	A	11	4	6,8	13	56	11	6,8	M8
18	35	100	A	11	4	6,8	13	76	11	6,8	M8
18	35	120	B	11	4	6,8	13	96	11	6,8	M8
18	35	140	B	11	4	6,8	13	116	11	6,8	M8
18	35	160	B	11	4	6,8	13	136	11	6,8	M8
24	51	100	A	15	6	9,0	15	68	15	8,5	M10
24	51	120	A	15	6	9,0	15	88	15	8,5	M10
24	51	140	B	15	6	9,0	15	108	15	8,5	M10
24	51	160	B	15	6	9,0	15	128	15	8,5	M10
24	51	180	B	15	6	9,0	15	148	15	8,5	M10
30	65	120	A	18	6	11,0	15	80	18	10,5	M12
30	65	140	A	18	6	11,0	15	100	18	10,5	M12
30	65	160	B	18	6	11,0	15	120	18	10,5	M12
30	65	180	B	18	6	11,0	15	140	18	10,5	M12
30	65	200	B	18	6	11,0	15	160	18	10,5	M12

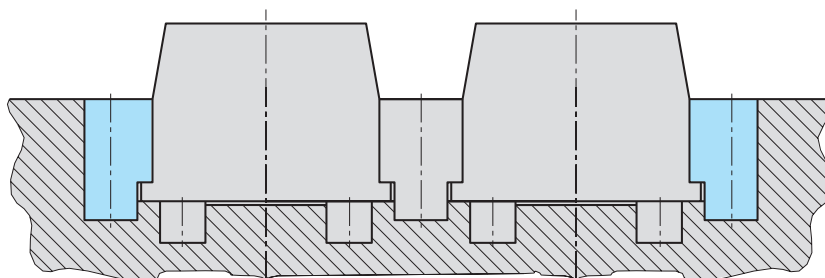
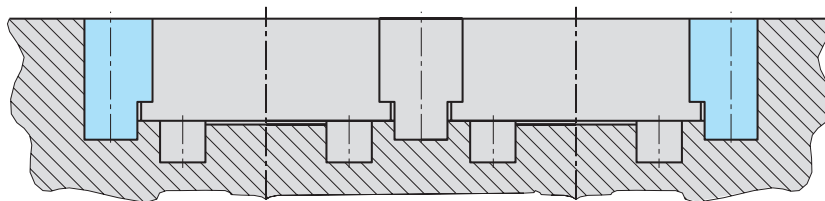
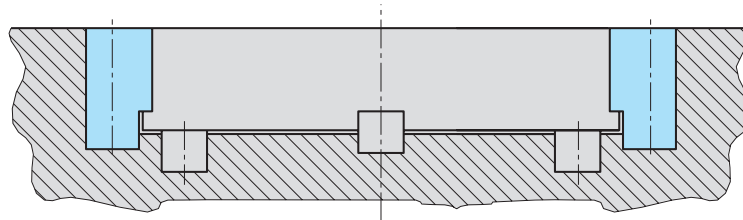
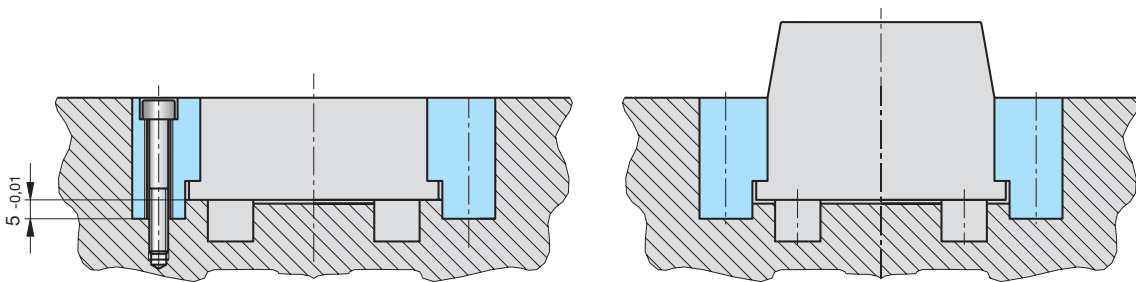

5

Führungsleisten

Guide strips

Barres de guidage

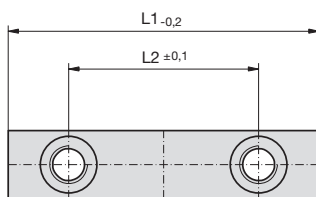
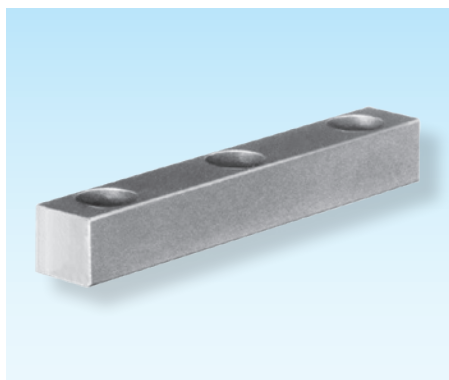

Type A

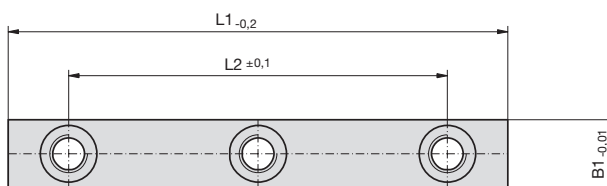
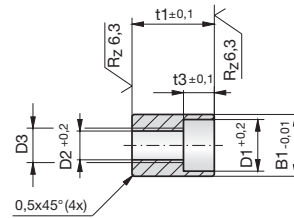
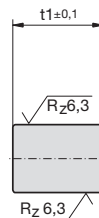

Type B

Z4248-

Mat.: ST
58 +2HRC



Z4248-B1-t1-L1



B1	t1	L1	Type	t3	L2	D1	D2	D3
12	11	50	A	5,7	30	10	5,3	M6
12	11	60	A	5,7	40	10	5,3	M6
12	11	70	B	5,7	50	10	5,3	M6
12	11	75	B	5,7	60	10	5,3	M6
12	11	80	B	5,7	60	10	5,3	M6
12	11	90	B	5,7	70	10	5,3	M6
12	16	100	B	5,7	80	10	5,3	M6
12	16	120	B	5,7	100	10	5,3	M6
12	16	140	B	5,7	120	10	5,3	M6
12	16	160	B	5,7	140	10	5,3	M6
12	16	180	B	5,7	160	10	5,3	M6
18	16	100	A	6,8	76	11	6,8	M8
18	16	120	A	6,8	96	11	6,8	M8
18	16	140	B	6,8	116	11	6,8	M8
18	16	160	B	6,8	136	11	6,8	M8
18	16	180	B	6,8	156	11	6,8	M8
24	21	140	B	6,8	116	11	6,8	M8
24	21	160	B	6,8	136	11	6,8	M8
24	21	180	B	6,8	156	11	6,8	M8
24	21	200	B	6,8	176	11	6,8	M8
24	21	220	B	6,8	196	11	6,8	M8

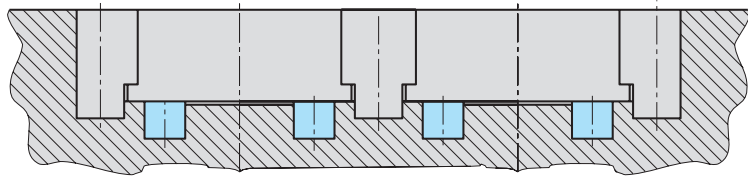
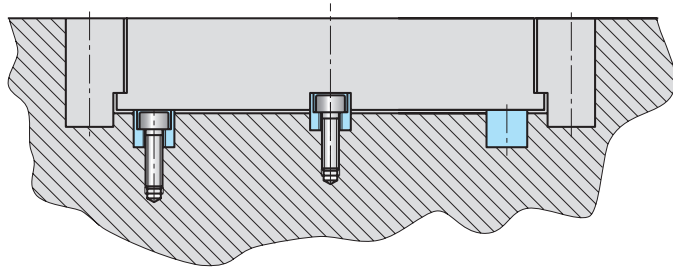

Schrägschieber mit Gelenk

Slanted slides with articulation

Tiroirs obliques avec articulation

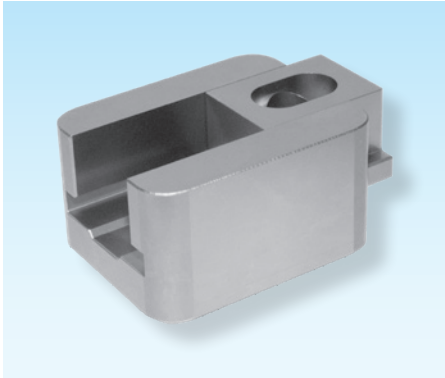

Z4278-

Mat.: 1.2842/58 +2HRC
Mat.: 1.2343/52 +2HRC



Z4278-D1



Mit verbesserter Verdrehsicherung,
Ersatz für **Z4277**

With improved anti-twist protection,
replacement for **Z4277**

Avec dispositif anti-torsion amélioré,
remplacement de **Z4277**

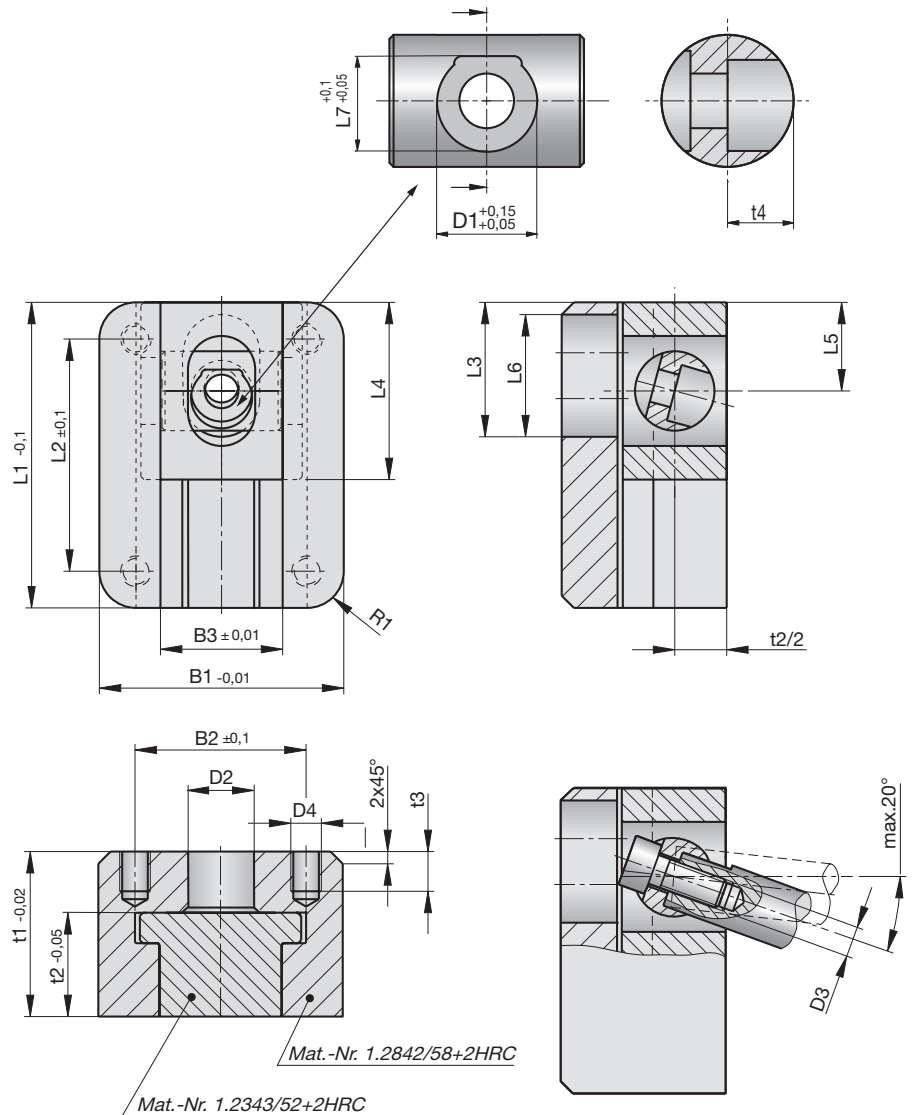

5

D1	B1	B2	B3	t1	t2	t3	L1	L2	L3	L4	L5	L6	D2	D3	D4	R1	t4	L7
10	40	28	20	27	17	6,5	50	38	22	29	14,5	20	12,5	M5	M5	6	6,5	9
12	48	34	24	34	22	8,0	60	46	24	34	17,0	21	12,5	M6	M6	7	8	11
16	64	44	32	45	29	10,0	80	60	31	46	23,0	28	16,5	M8	M8	10	11	14,5

Einbaubeispiel
Example of installation
Exemple de montage

5

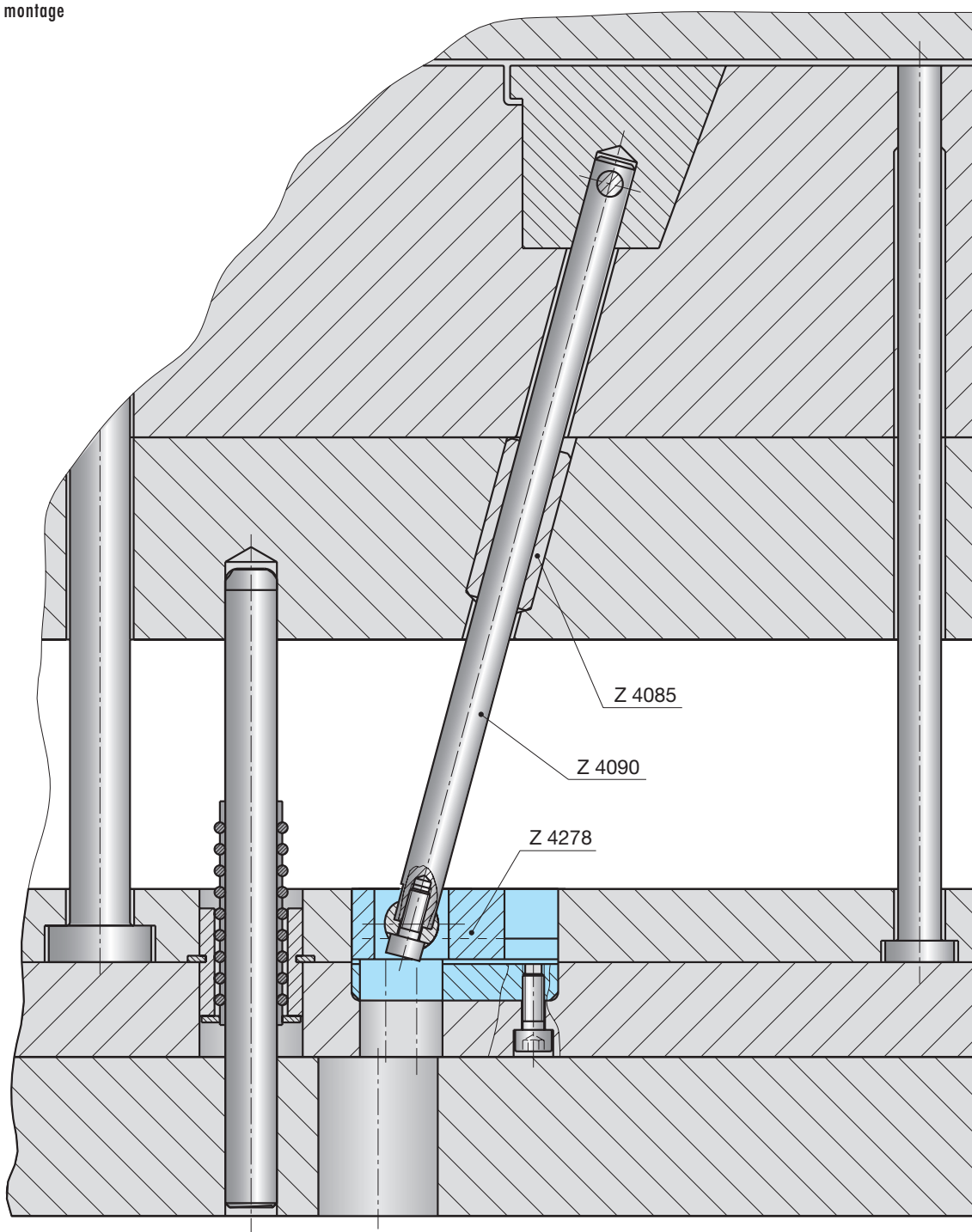

Minischieber

Mini-Slide unit

Mini-Tiroir unité

DLC

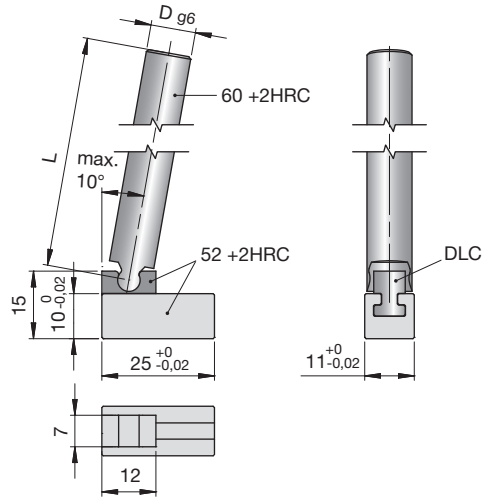
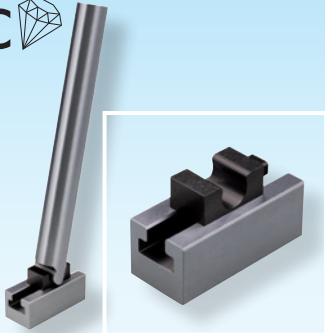

Z4279-

Mat.: ST
DLC

Z4279-D-L



D

10

L

400

5

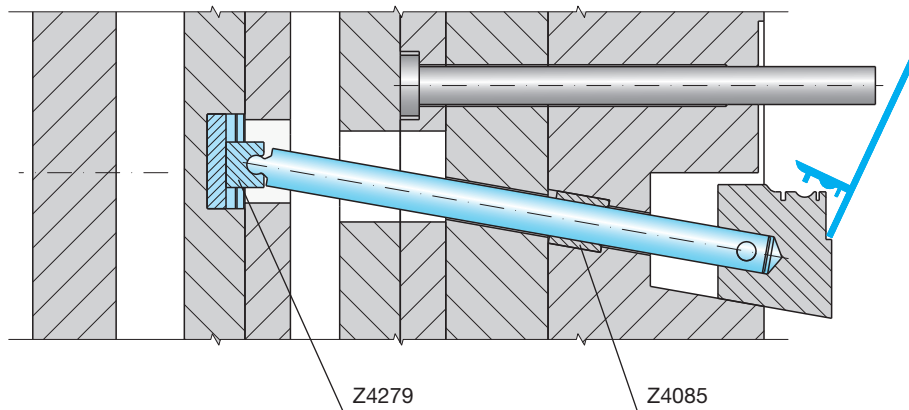
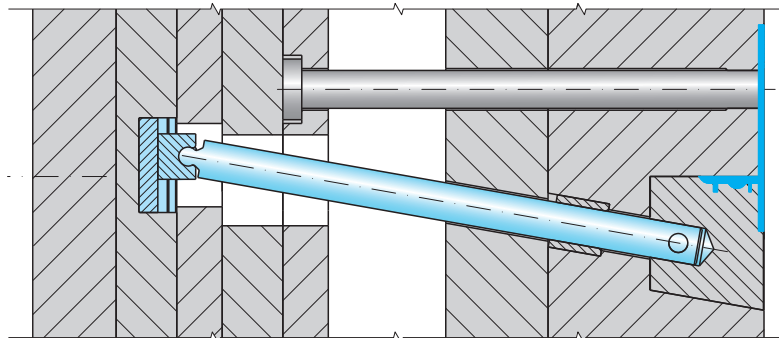

Gleitführungsbuchsen

Guide bushes

Bagues pour guidage lisse

Mat.: Ampco 18

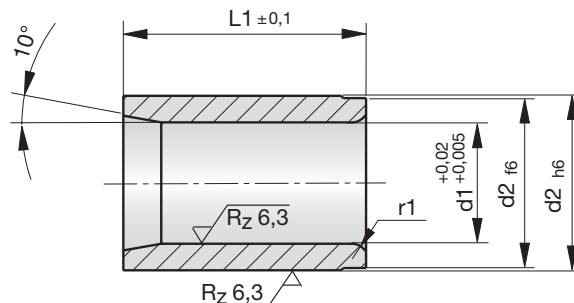

Z4085-

Mat.: Ampco18
HB 30=193 <300 °C



Z4085-d1-L1



d1	L1	d2	r1
10	14	14	1,0
10	20	14	1,0
12	20	17	1,5
12	25	17	1,5
16	25	22	2,0
16	32	22	2,0

5

Schrägsäulen

Angle pins

Doigtes incliné

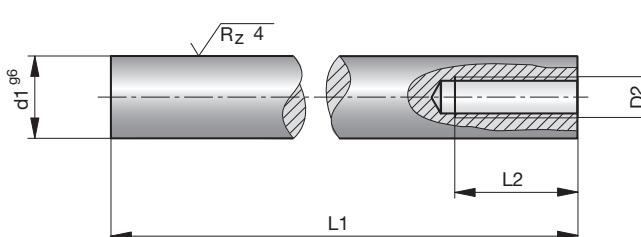
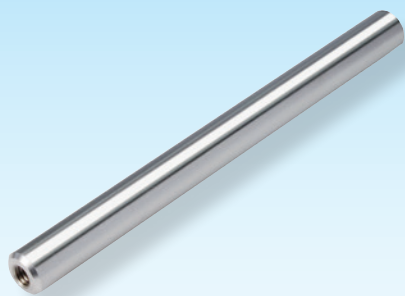

Z4090-

Mat.: 1.7131
58+4HRC



Z4090-d1



d1	L1	L2	D2
10	180	15	M5
12	210	18	M6
16	250	22	M8

Schiebereinheiten

Slide units

Unités de tiroirs

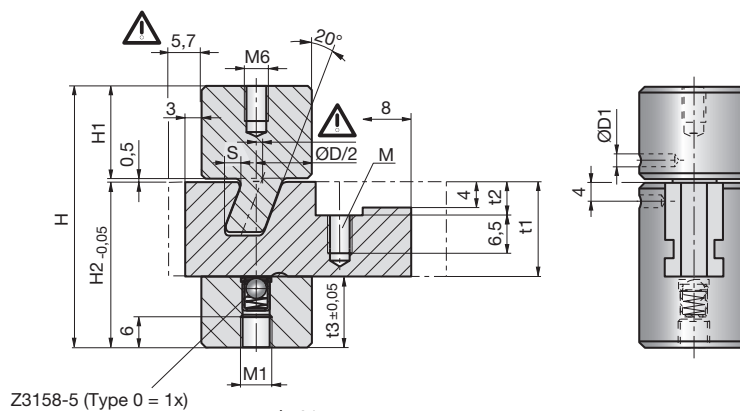
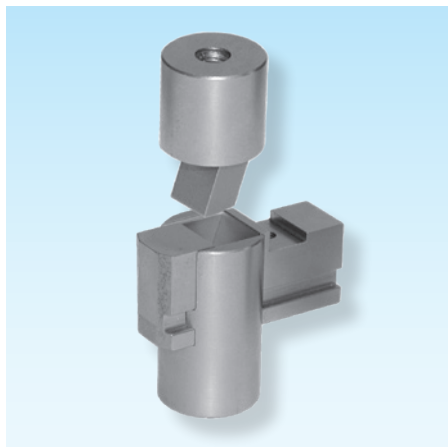

Z4290-

Mat.: 1.2343
52HRC

Z4290-Type

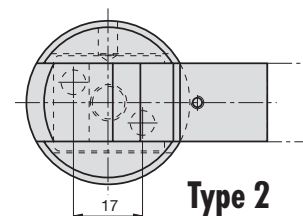
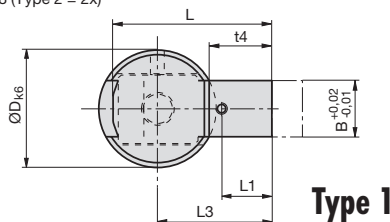
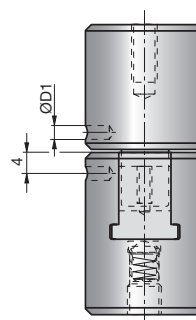
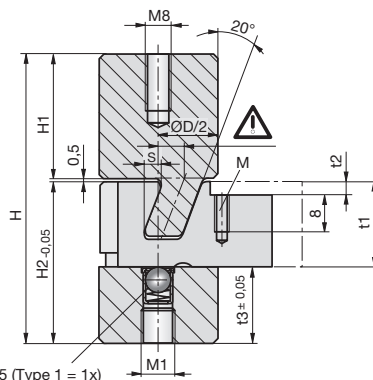
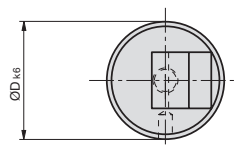
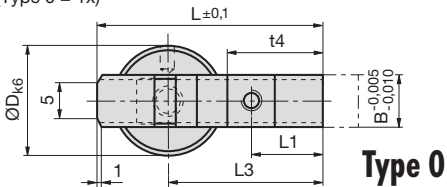

Type	D	B	S	H	H1	H2	t1	t2	t3	L	L1	t4	L3	D1	M1	M
0	16	10	2,7	44,0	15,0	28,5	16	6,0	12,5	36,0	12,0	16,0	25,0	3	M6	M4
1	25	11	3,4	61,5	26,5	34,5	18	2,5	16,5	32,8	10,8	13,9	24,2	3	M6	M3
2	40	22	6,4	60,5	20,0	40,0	28	8,0	12,0	50,0	8,0	20,0	37,0	4	M8	M5

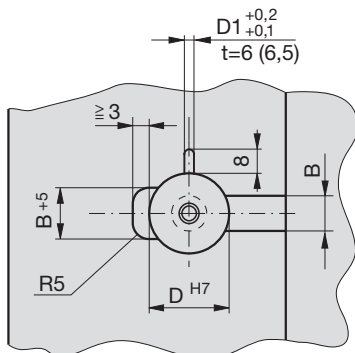
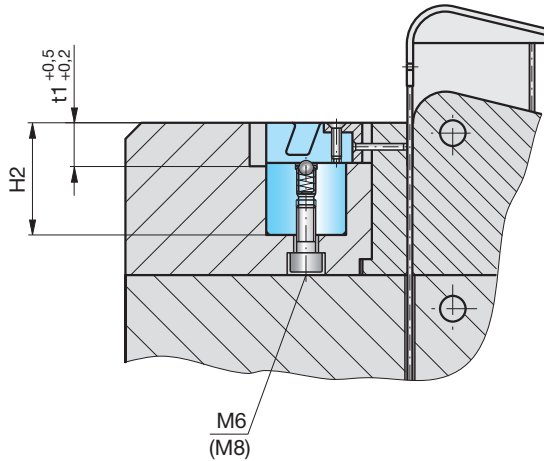
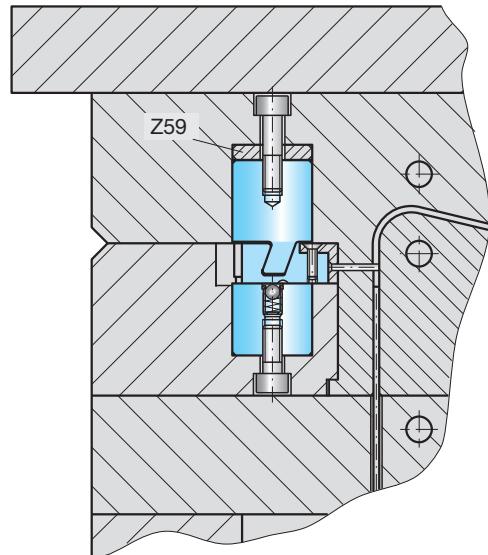
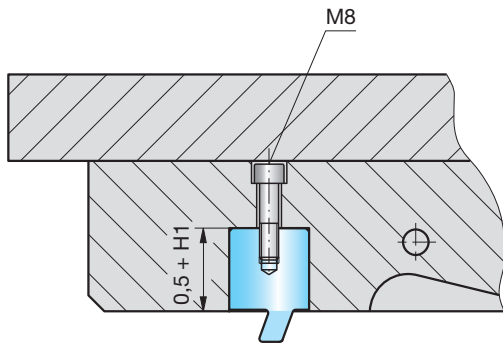
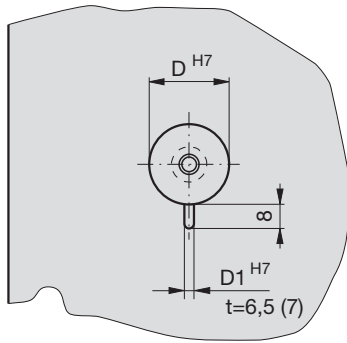

Schiebereinheiten

Slide units

Unités de tiroirs



Z4290L-

Mat.: 1.2343
52HRC



Z4290L-Type-L-D

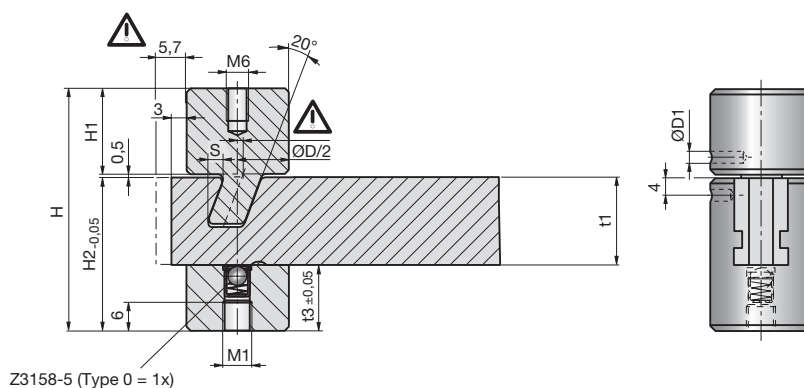

Z3158-5 (Type 0 = 1x)

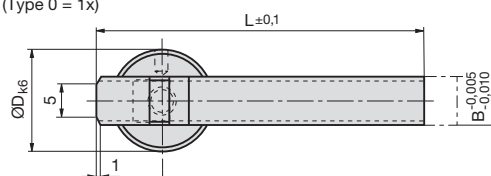

Type 0

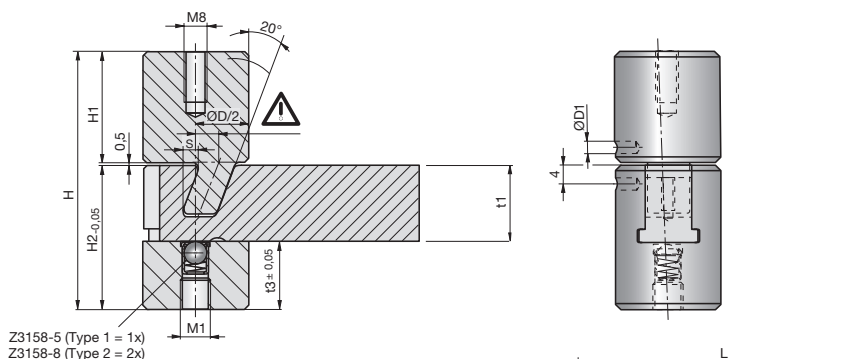
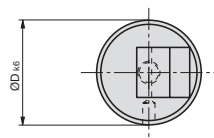

Z3158-5 (Type 1 = 1x)
Z3158-8 (Type 2 = 2x)

Type 1

Type 2

Type	L	D	B	S	H	H1	H2	t1	t3	D1	M1
0	80	16	10	2,7	44,0	15,0	28,5	16	12,5	3	M6
1	80	25	11	3,4	61,5	26,5	34,5	18	16,5	3	M6
2	100	40	22	6,4	60,5	20,0	40,0	28	12,0	4	M8

Schiebereinheiten

Slide units

Unités de tiroirs

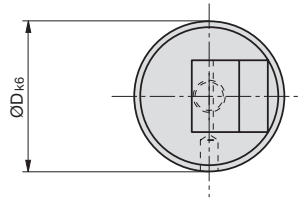
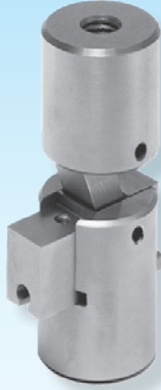

Z4292-

Mat.: 1.2343
52HRC

5

Z4292-Type

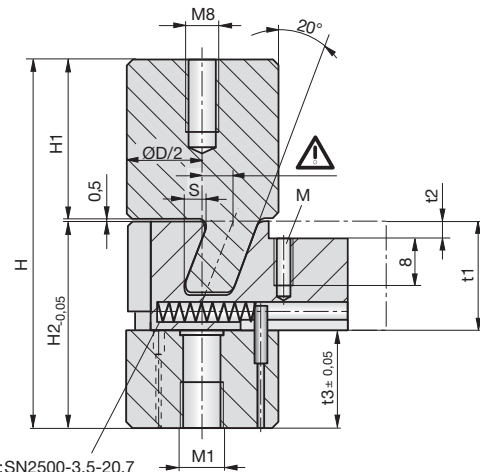

Type 1: SN2500-3,5-20,7
Type 2: SN2500-4,63-29

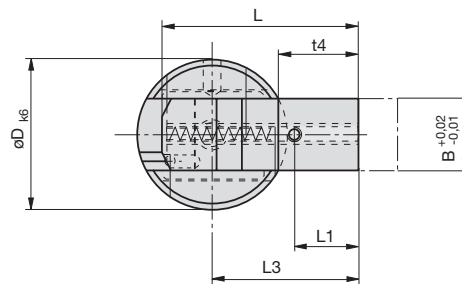
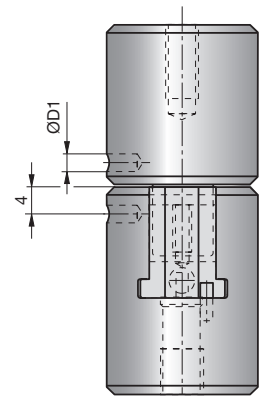

Type	D	B	S	H	H1	H2	t1	t2	t3	L	L1	t4	L3	D1	M1	M
1	25	11	3,4	61,5	26,5	34,5	18	2,5	16,5	32,8	10,8	13,9	24,2	3	M6	M3
2	40	22	6,4	60,5	20,0	40,0	28	8,0	12,0	50,0	8,0	20,0	37,0	4	M8	M5

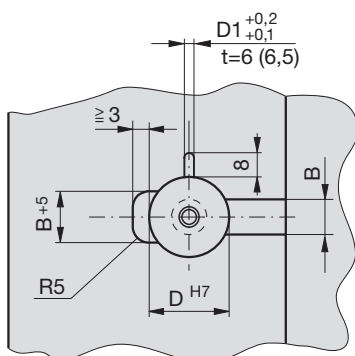
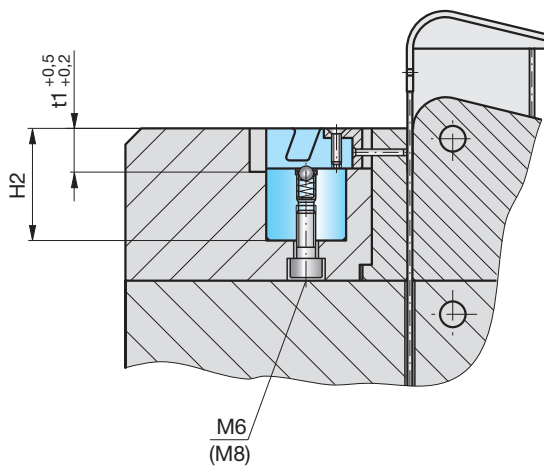
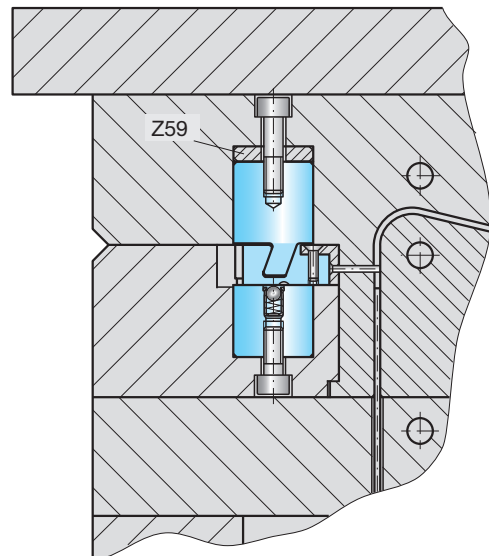
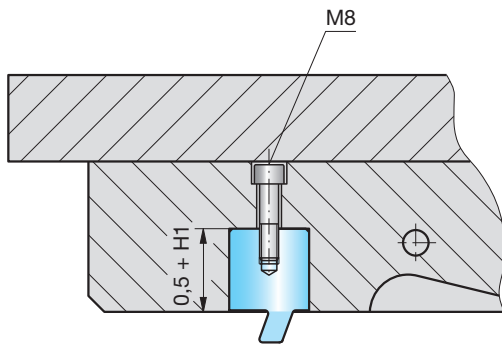
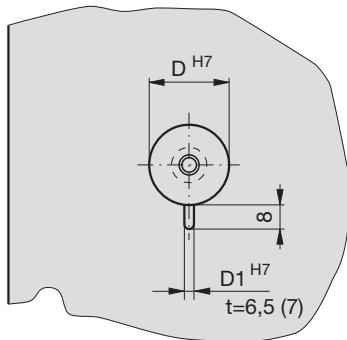

Schiebereinheiten

Slide units

Unités de tiroirs

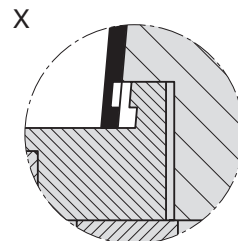
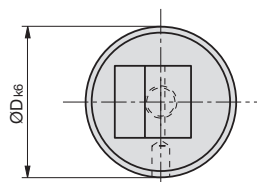
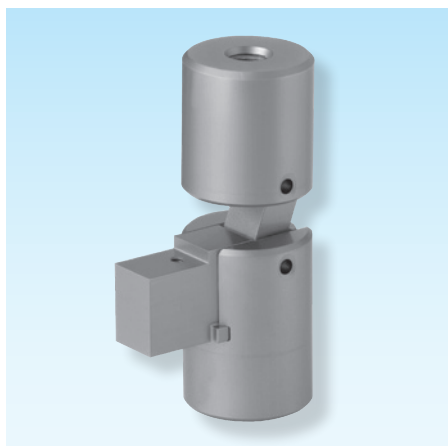

Schiebereinheit Z4293 für den Einsatz bei innenliegenden Hinterschnidungen.

Slide unit Z4293 for use with inner undercuts.

Unité de tiroir Z4293 pour les pièces à contre-dépouilles intérieures.

Z4293-

Mat.: 1.2343
52HRC

5

Z4293-Type

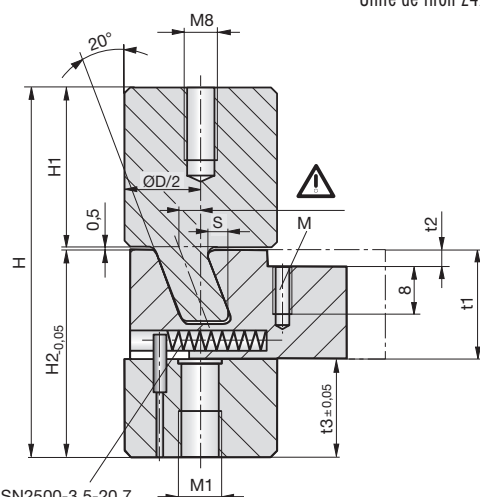

Type 1: SN2500-3,5-20,7
Type 2: SN2500-4,63-29

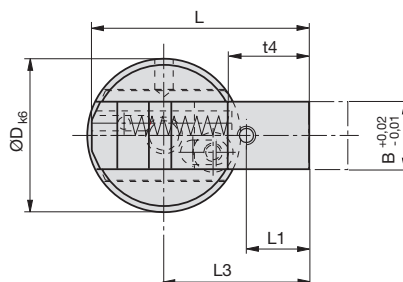
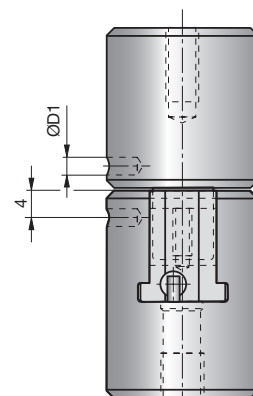

Type	D	B	S	H	H1	H2	t1	t2	t3	L	L1	t4	L3	D1	M1	M
1	25	11	3,4	61,5	26,5	34,5	18	2,5	16,5	36,0	10,8	13,9	24,2	3	M6	M3
2	40	22	6,4	60,5	20,0	40,0	28	8,0	12,0	56,5	8,0	20,0	37,0	4	M8	M5

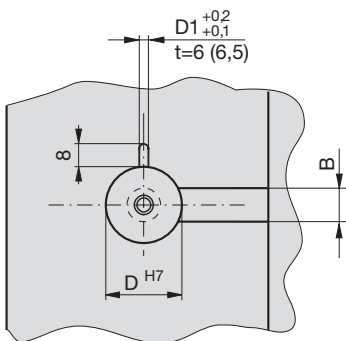
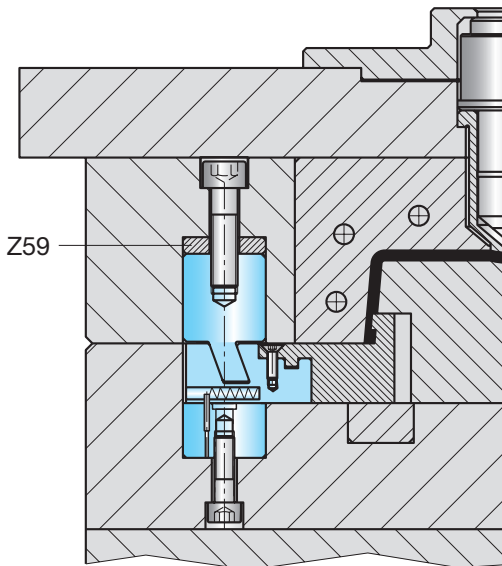
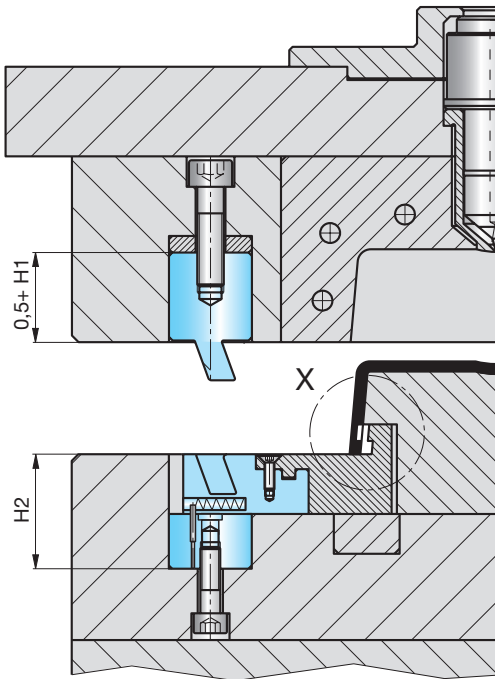
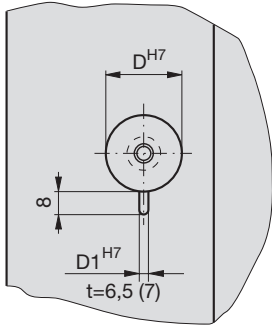

Schiebereinheiten

Slide units

Unités de tiroirs

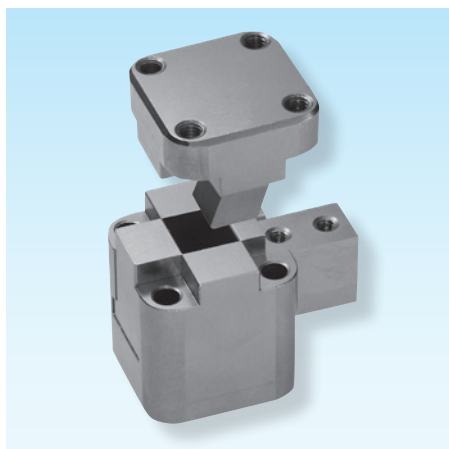

Z4294-

Mat.: 1.2343
52HRC

5

Z4294-Type

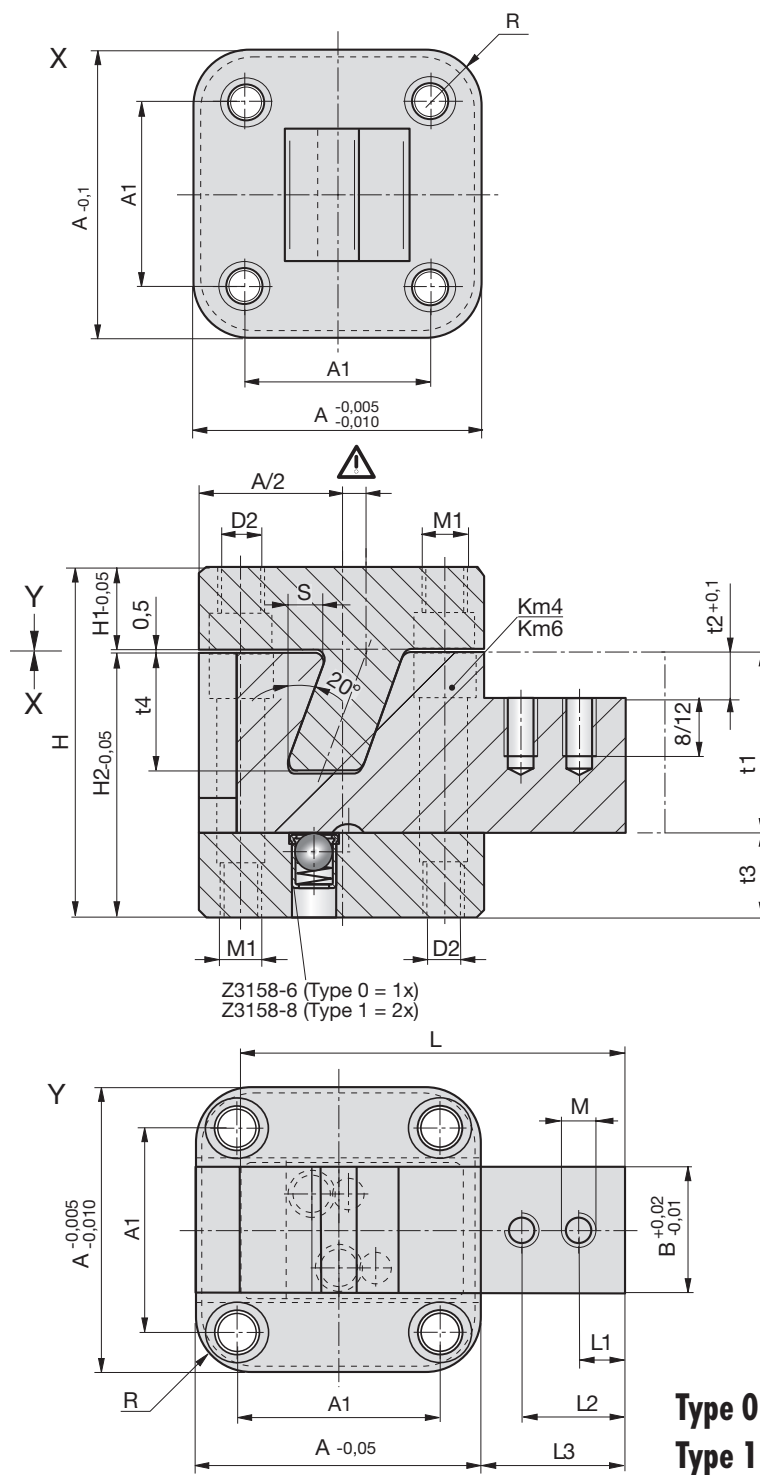

Type	A	B	A1	S	L	L1	L2	L3	H	H1	H2	t1	t2	t3	t4	M	M1	D2	R
0	32	12	22	4,9	46,8	5	15	20	50	14,5	35	23	6	12	16	M4	M5	4,1	6
1	50	22	36	6,7	66,8	6	18	25	60	14,5	45	30	6	15	21,5	M5	M8	6,5	8

Schiebereinheiten

Slide units

Unités de tiroirs

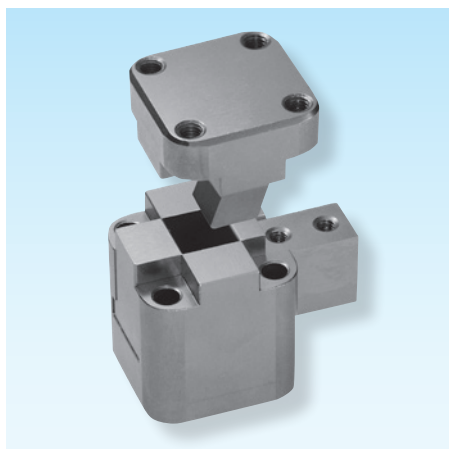

Z4294-

Mat.: 1.2343
52HRC



Z4294-Type

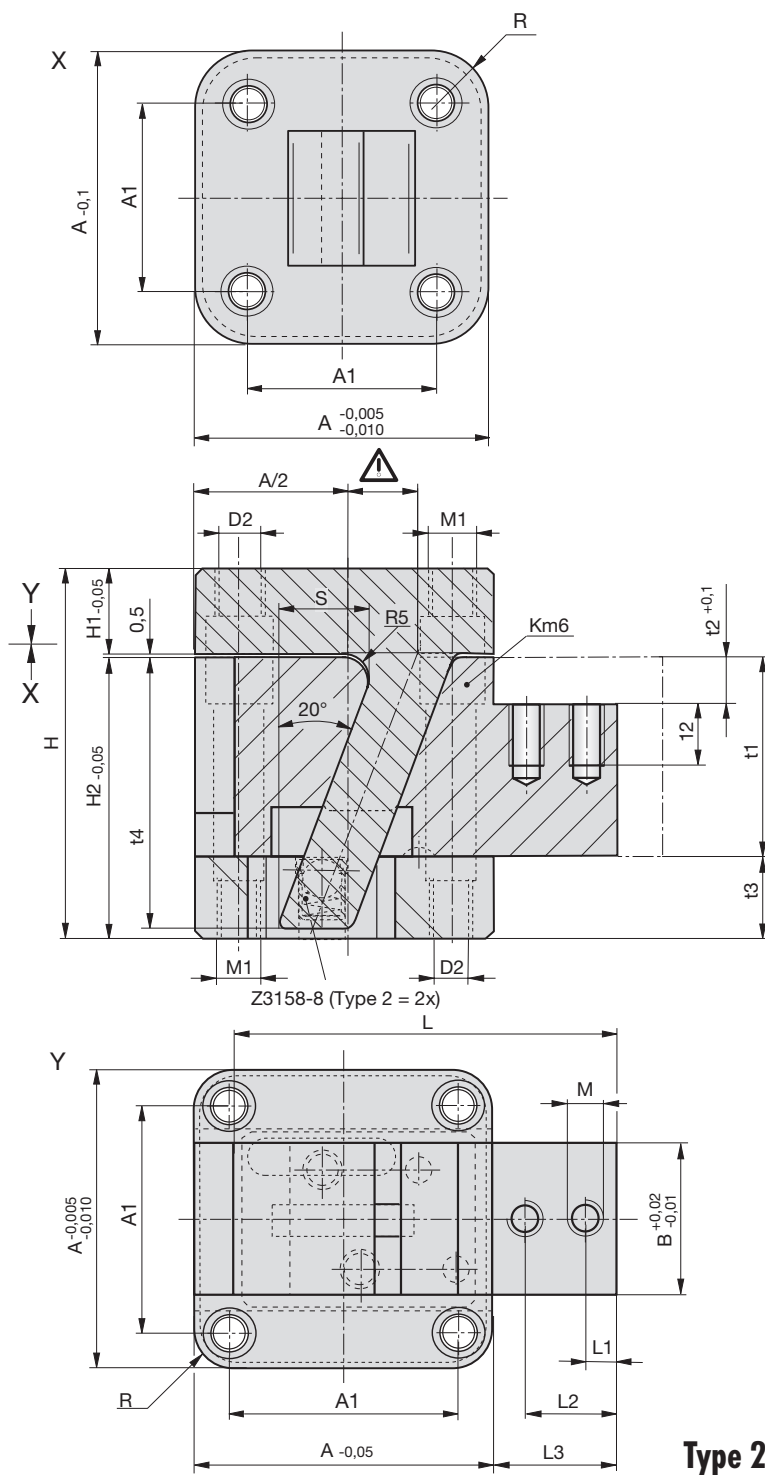

Type 2

Type	A	B	A1	S	L	L1	L2	L3	H	H1	H2	t1	t2	t3	t4	M	M1	D2	R
2	60	31	46	17,3	74,8	6	18	25	72	14,5	57	40	10	17	55	M5	M8	6,5	8

5

Schiebereinheiten

Slide units

Unités de tiroirs



Z4294L-

Mat.: 1.2343
52HRC

5



Z4294L-Type-L-A

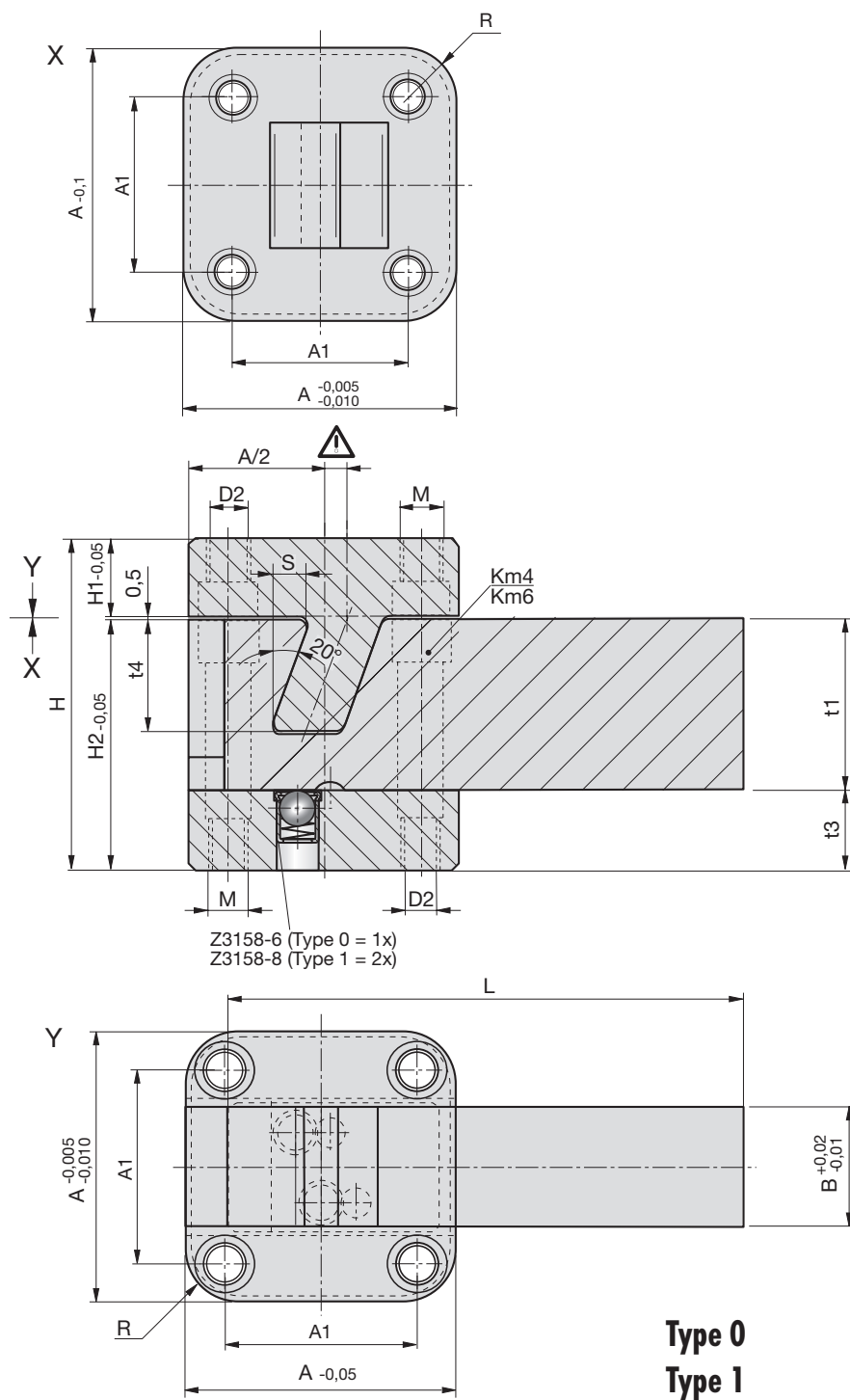

Type	L	A	B	A1	S	H	H1	H2	t1	t3	t4	M	D2	R
0	100	32	12	22	4,9	50	14,5	35	23	12	16	M5	4,1	6
1	100	50	22	36	6,7	60	14,5	45	30	15	21,5	M8	6,5	8

Schiebereinheiten

Slide units

Unités de tiroirs



Z4294L-

Mat.: 1.2343
52HRC



Z4294L-Type-L-A

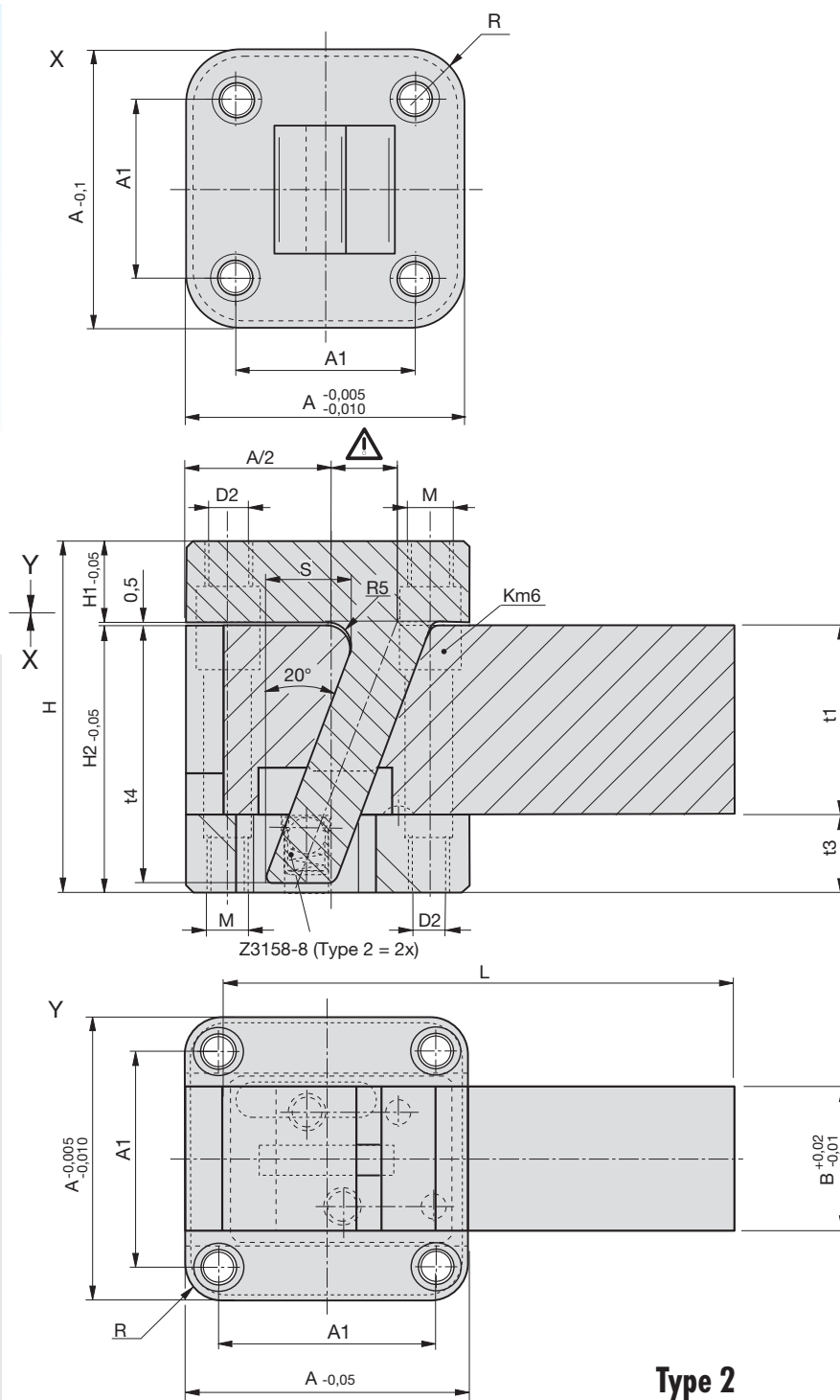

Type 2

Type	L	A	B	A1	S	H	H1	H2	t1	t3	t4	M	D2	R
2	140	60	31	46	17,3	72	14,5	57	40	17	55	M8	6,5	8

Schiebereinheiten

Slide units

Unités de tiroirs

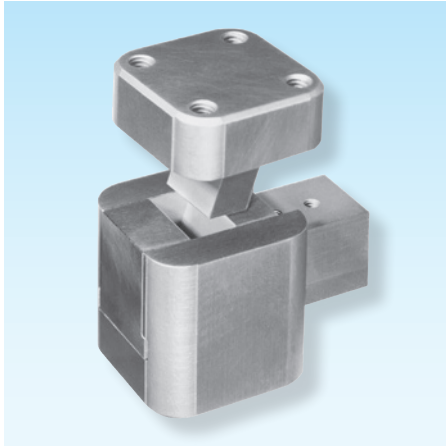

Z4295-

Mat.: 1.2343
52HRC

5

Z4295-Type

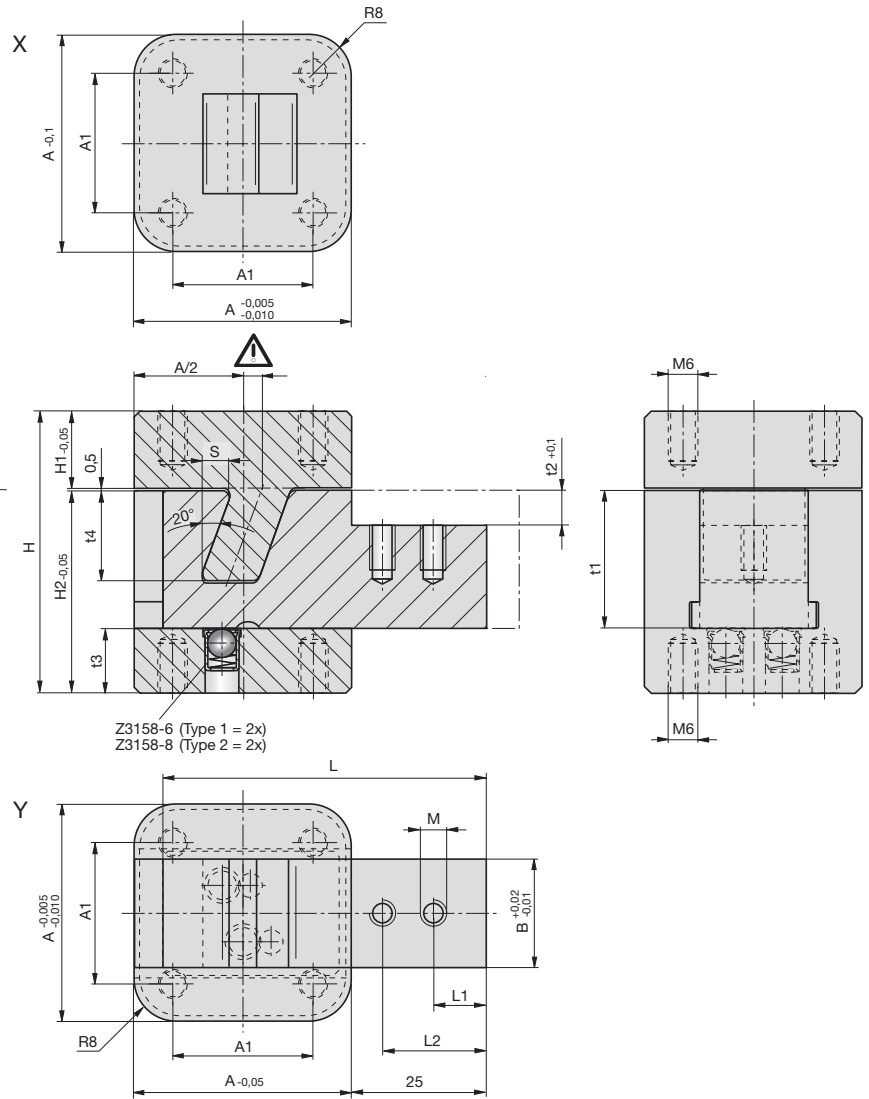

D 3002A 10.2018

Type	A	B	A1	S	L	L1	L2	H	H1	H2	t1	t2	t3	t4	M
1	40	20	26	4,9	59,8	10	20	52	14,5	37	25	6	12	16	M4
2	60	35	46	9,9	74,8	6	18	72	14,5	57	40	10	17	30	M5

Schiebereinheiten

Slide units

Unités de tiroirs

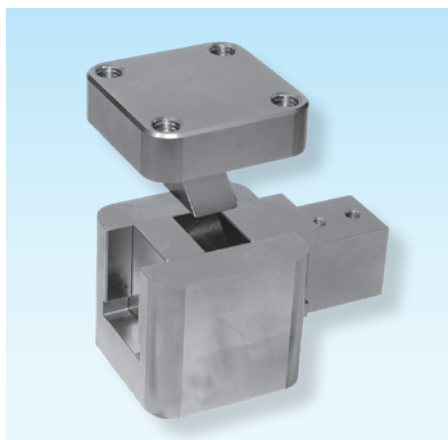

Z4296-

Mat.: 1.2343
52HRC

Z4296-Type

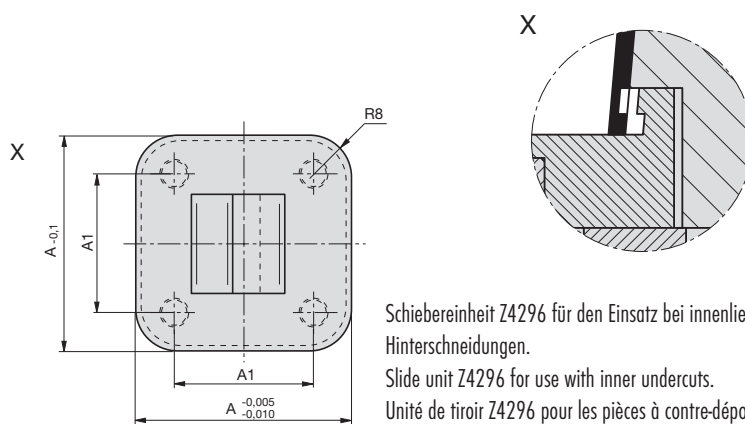

Schiebereinheit Z4296 für den Einsatz bei innenliegenden Hinterschnidungen.

Slide unit Z4296 for use with inner undercuts.

Unité de tiroir Z4296 pour les pièces à contre-dépouilles intérieures.

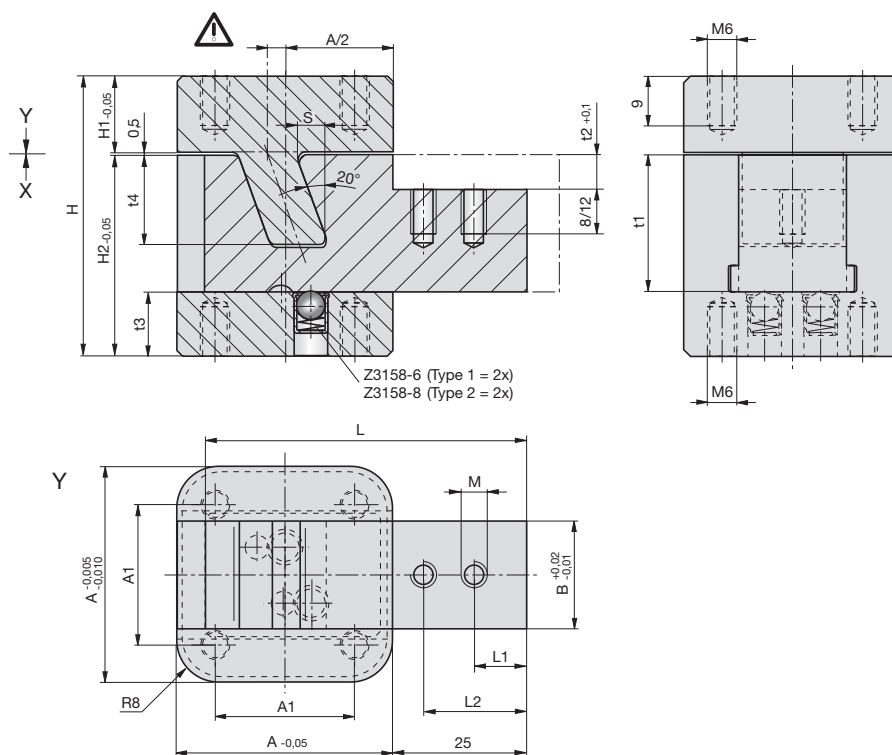

Z3158-6 (Type 1 = 2x)
Z3158-8 (Type 2 = 2x)

5

Type	A	B	A1	S	L	L1	L2	H	H1	H2	t1	t2	t3	t4	M
1	40	20	26	4,9	59,8	10	20	52	14,5	37	25	6	12	16	M4
2	60	35	46	9,9	84,0	6	18	72	14,5	57	40	10	17	30	M5

Schiebereinheiten

Slide units

Unités de tiroirs

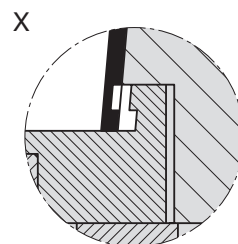
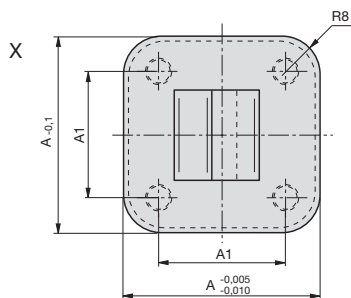

Schiebereinheit Z4296L für den Einsatz bei innenliegenden Hinterschnitten.

Slide unit Z4296L for use with inner undercuts.

Unité de tiroir Z4296L pour les pièces à contre-dépouilles intérieures.

Z4296L-

Mat.: 1.2343
52HRC

5



Z4296L-Type-L-A

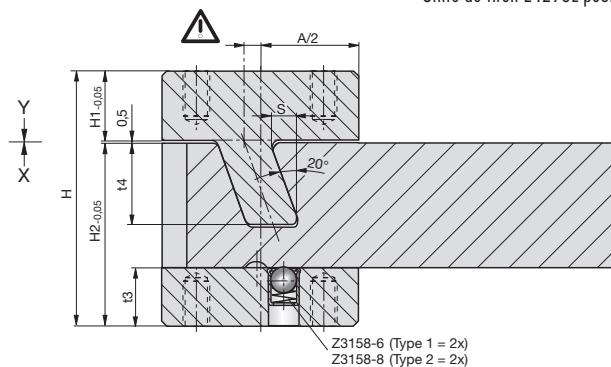

Z3158-6 (Type 1 = 2x)
Z3158-8 (Type 2 = 2x)

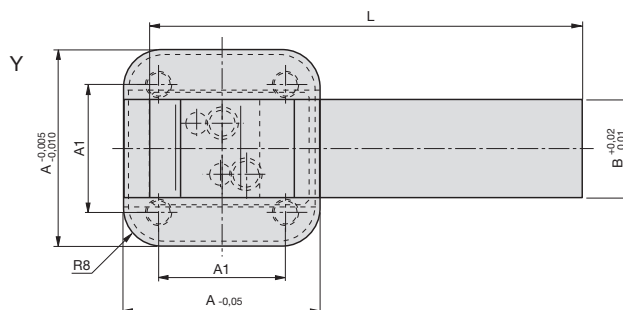
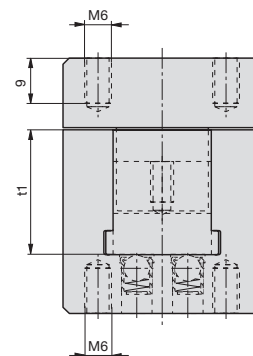

Type	L	A	B	A1	S	H	H1	H2	t1	t3	t4
1	100	40	20	26	4,9	52	14,5	37	25	12	16
2	140	60	35	46	9,9	72	14,5	57	40	17	30

Schiebereinheiten

Slide units

Unités de tiroirs

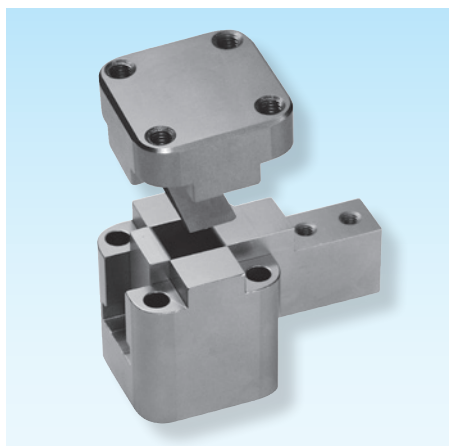

Z4298-

Mat.: 1.2343
52HRC

5

Z4298-Type

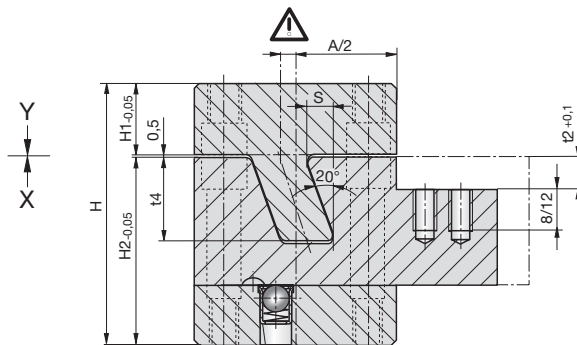
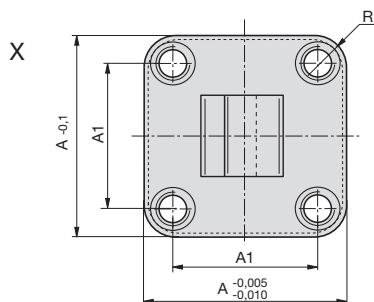

Z3158-6 (Type 0 = 1x)
Z3158-8 (Type 1 = 2x)

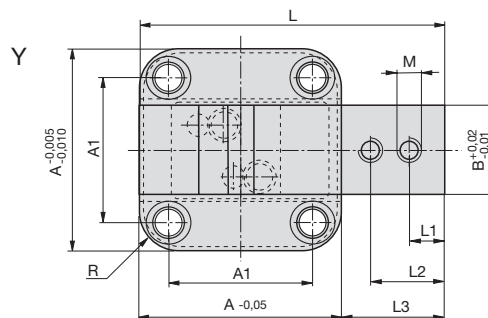
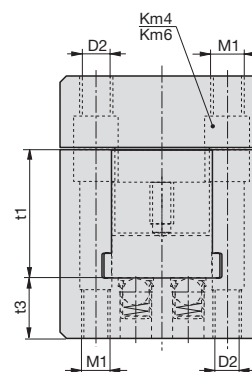

Type	A	B	A1	S	L	L1	L2	L3	H	H1	H2	t1	t2	t3	t4	M	M1	D2	R
0	32	12	22	4,9	51,5	5	15	20	50	14,5	35	23	6	12	16	M4	M5	4,1	6
1	50	22	36	6,7	74,5	6	18	25	60	14,5	45	30	6	15	21,5	M5	M8	6,5	8

Konstruktionsbeispiele

Examples of construction

Exemples d'application

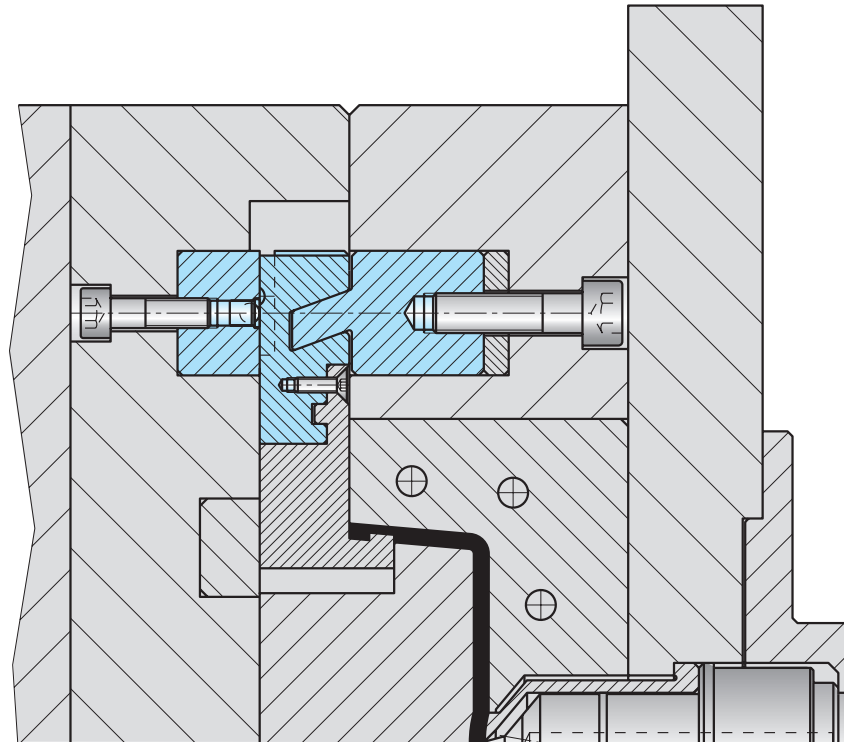

Schiebereinheit Z4293 (Z4296/ Z4296L/Z4298) für den Einsatz bei innenliegenden Hinterschneidungen.
Slide unit Z4293 (Z4296/ Z4296L/Z4298) for use with inner undercuts.
Unité de tiroir Z4293 (Z4296/ Z4296L/Z4298) pour les pièces à contre-dépouilles intérieures.

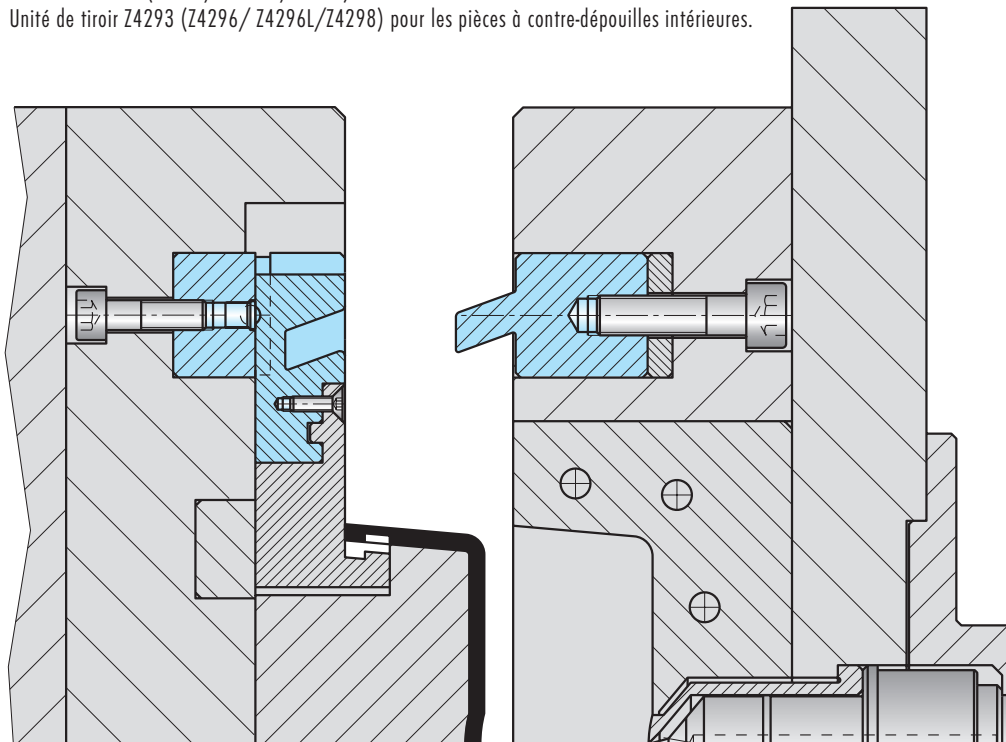

SCHIEBERHALTEVORRICHTUNGEN

SLIDE HOLDING DEVICES

VERROUS DE TIROIRS

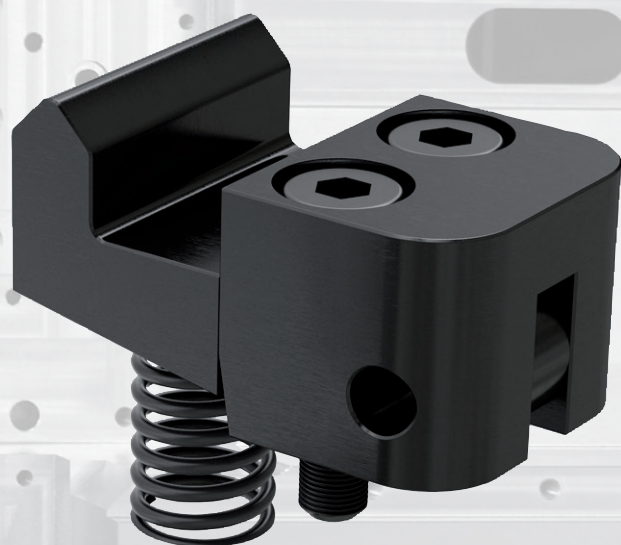
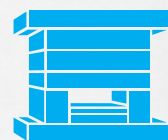

STRACK®

NORMALIEN

Schieberhaltevorrichtungen

Slide holding devices

Verrous de tiroirs

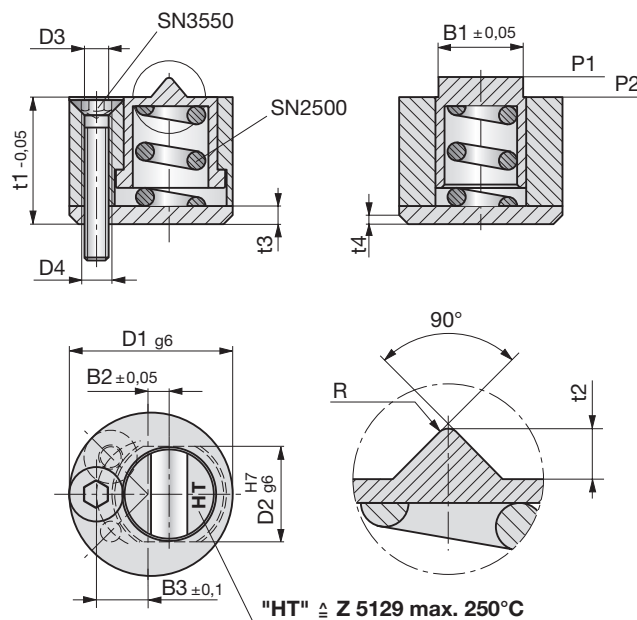
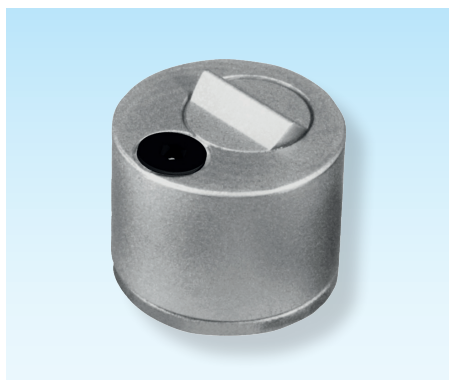

Z5129-
Z5130-

Mat.: 1.2767
~52HRC

Z5129-D1
Z5130-D1



5

Z5129 max. 250 °C

Z5130 max. 100 °C

D1	B1	B2	B3	t1	t2	t3	t4	D2	D3	D4	R	P1	P2	P1 (HT)	P2 (HT)	SN2500-	SN3550-
13	6,6	1,4	4,3	10	1,0	1,6	0,35	7	2,2	M3	0,35	28 N	34 N	21 N	28 N	5-12	M2-16
18	9,6	2,0	6,0	14	1,8	2,0	0,50	10	3,2	M4	0,50	38 N	42 N	26 N	35 N	8-16,5	M3-20
27	14,4	3,0	9,0	21	2,8	3,0	0,50	15	4,3	M5	0,75	38 N	92 N	33 N	82 N	11,6-18,5	M4-25

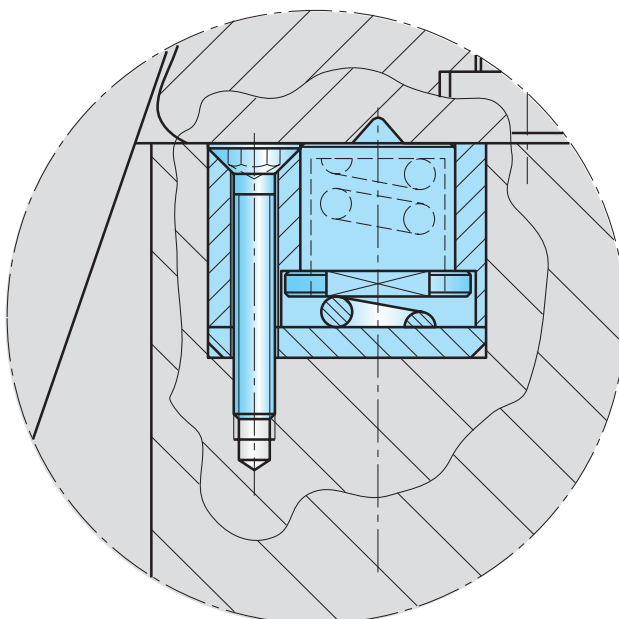

Einrastplatten

Snap-in plates

Plaquettes de retenue

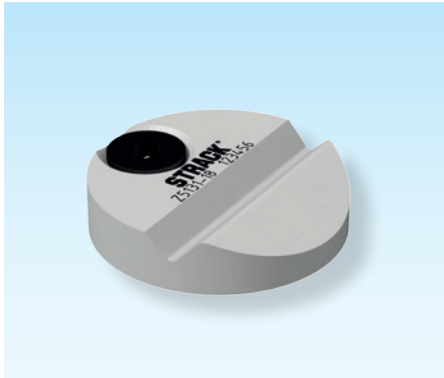

Z5131-

Mat.: ST

Z5131-D1

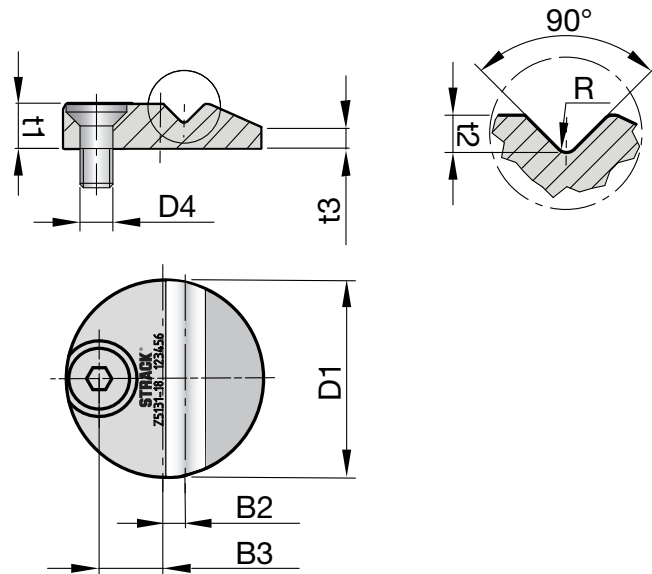

D1	B2	B3	t1	t2	t3	D4	R	SN3550-
13	1,4	4,3	3	0,8	1,7	M2	0,35	M2-8
18	2,0	6,0	4	1,6	1,9	M3	0,50	M3-10
27	3,0	9,0	5	2,6	1,9	M4	0,75	M4-12

5

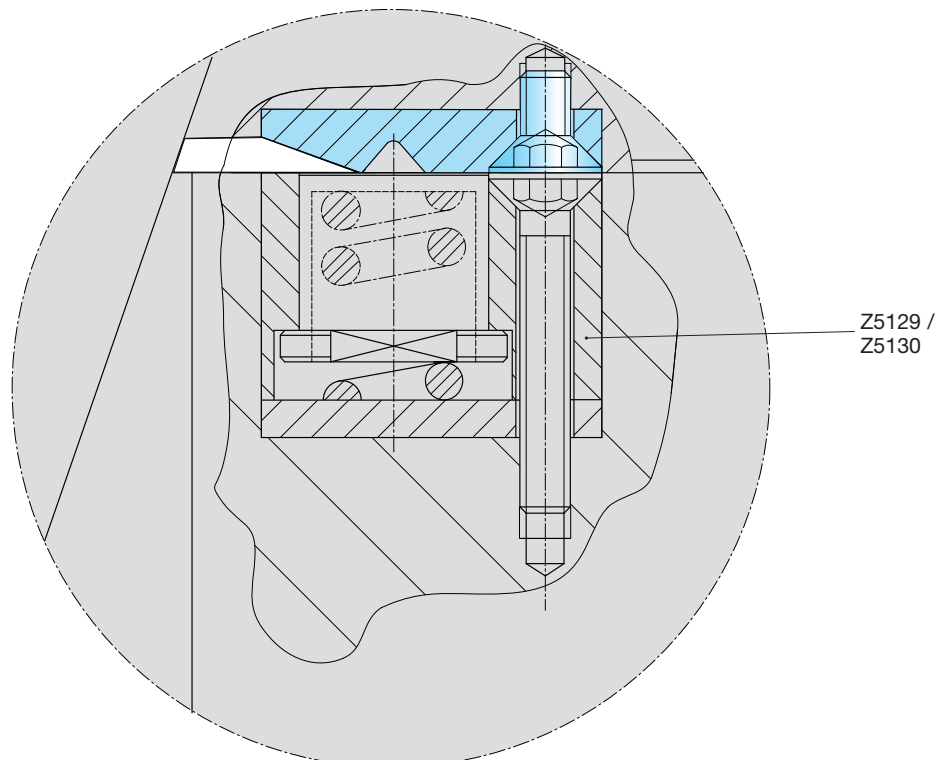

Schieberhaltevorrichtungen

Slide holding devices

Verrous de tiroirs

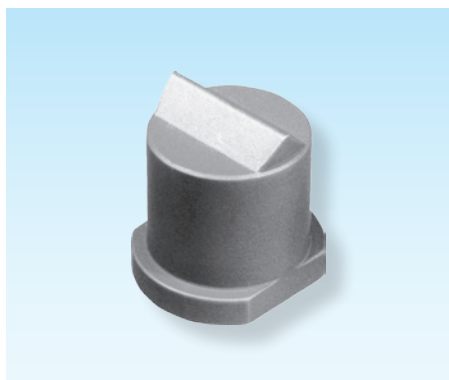

**Z5133-
Z5134-**

Mat.: 1.2767
~ 52HRC

Z5133-D2
Z5134-D2



5

Z5133 max. 250 °C

Z5134 max. 100 °C

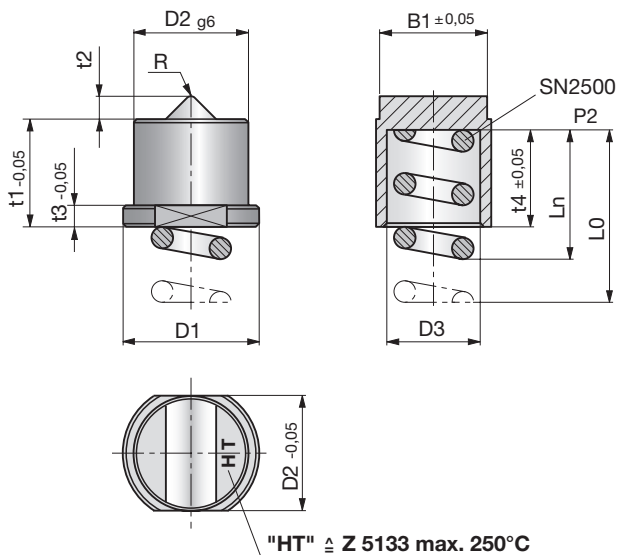

"HT" ≙ Z 5133 max. 250°C

D2	B1	t1	t2	t3	t4	D1	D3	R	L0	Ln	P2	P2 (HT)	SN2500-
7	6,6	7	1,0	1,4	6,3	8,4	5,3	0,35	12	7,5	34 N	28 N	5-12
10	9,6	10	1,8	2,0	9,0	12,0	8,3	0,50	16	10,0	42 N	35 N	8-16,5
15	14,4	15	2,8	3,0	13,5	18,0	12,4	0,75	18	16,0	92 N	82 N	11,6-18,5

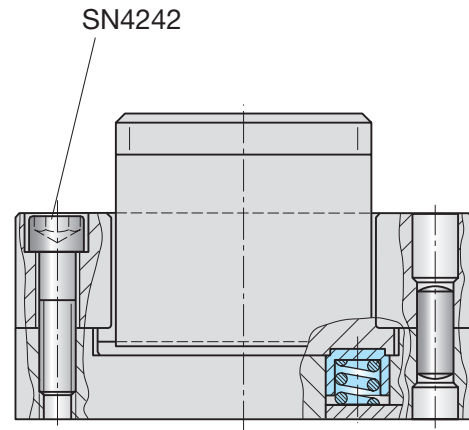
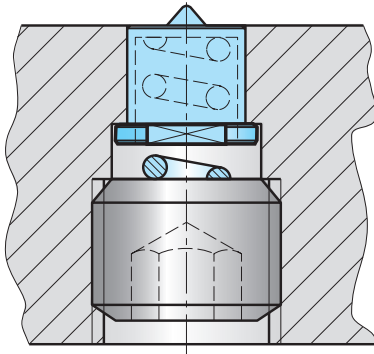
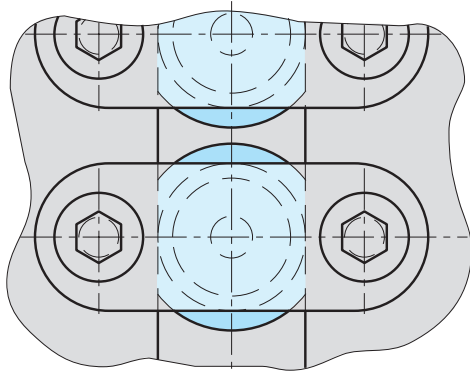

Schieberhaltevorrichtungen

Slide holding devices

Verrous de tiroirs

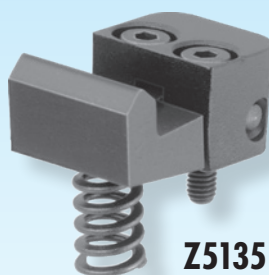

Z5135

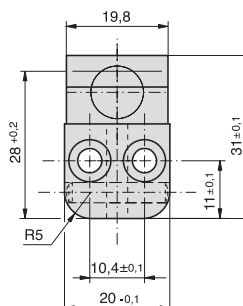
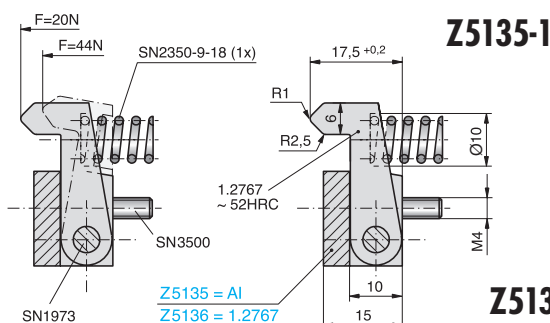

Z5136-1

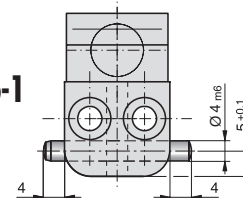

Type 1

5

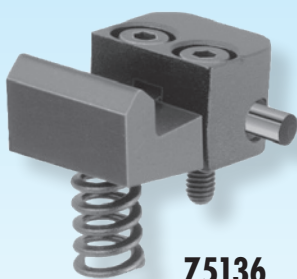

Z5136

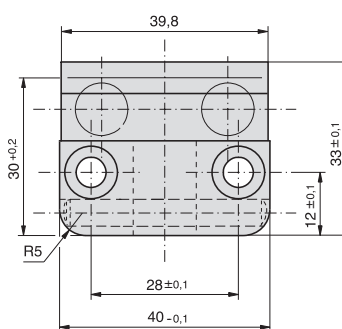
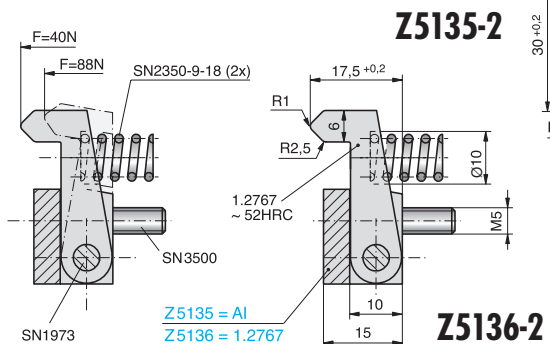

Z5136-2

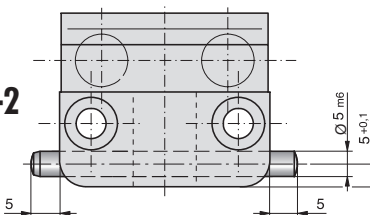

Type 2

Z5135-

Mat.: 1.2767/Al
max. 100 °C



Z5135-Type



Z5136-

Mat.: 1.2767
max. 100 °C



Z5136-Type



Type

SN3500-

SN1973-

1

M4-16

4-18

2

M5-16

5-36

Type

SN3500-

SN1973-

1

M4-16

4-28

2

M5-16

5-50

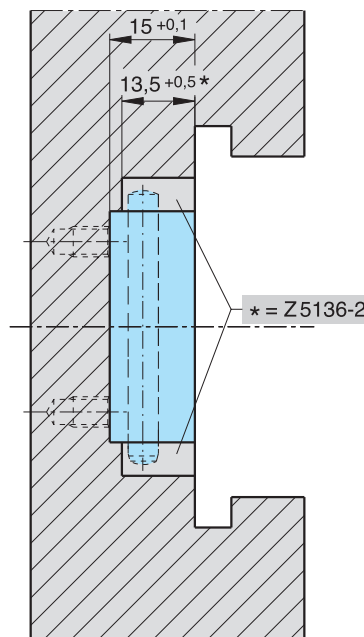
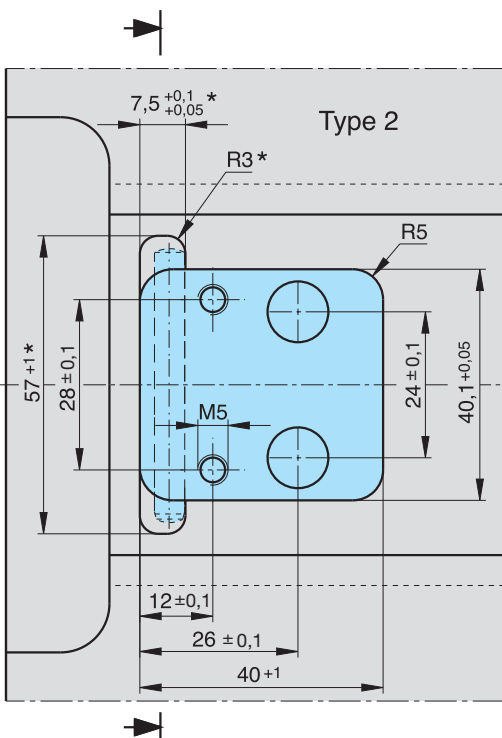
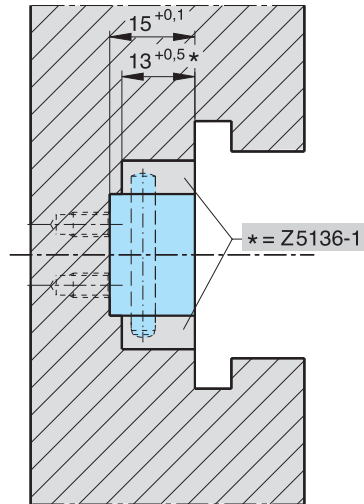
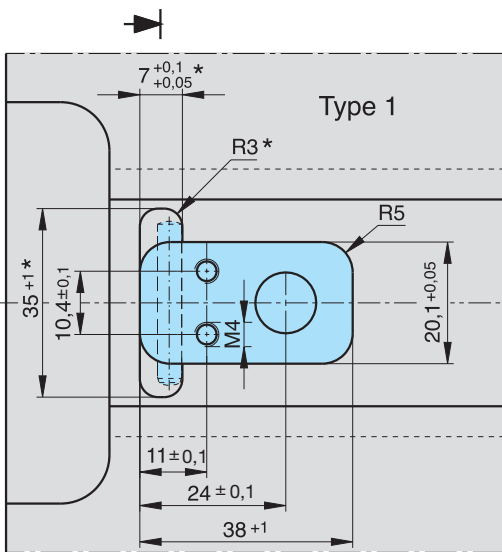
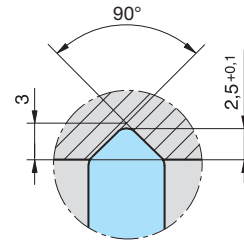
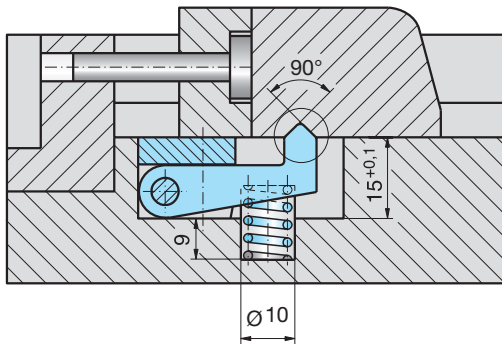

Schieberhaltevorrichtungen

Slide holding devices

Verrous de tiroirs



Type 0

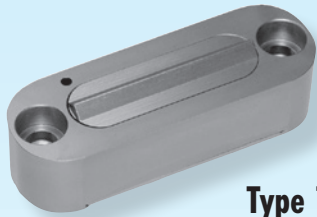

Type 1

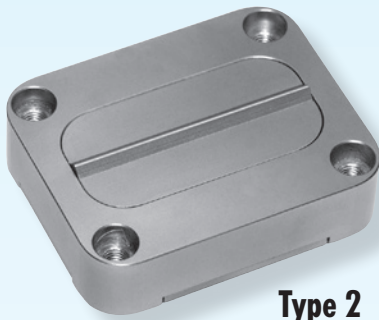

Type 2

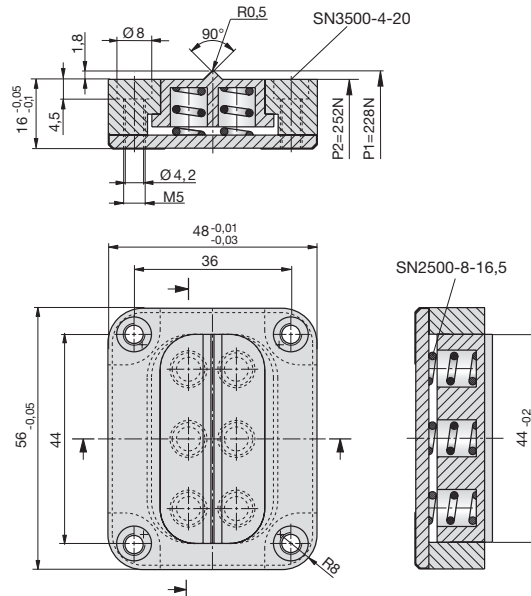
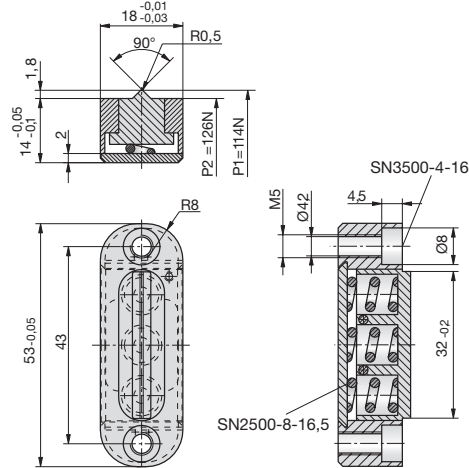
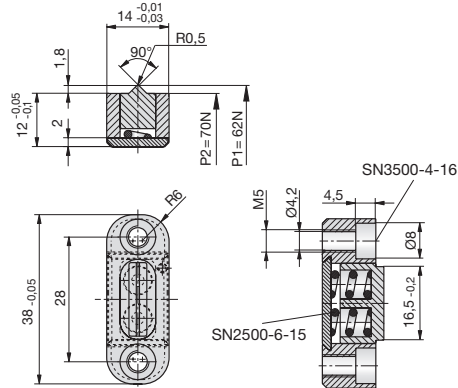

5

Z5140-

Mat.: ST/~52HRC
max. 100 °C

Z5140-Type



Type

0

1

2

Schieberhaltevorrichtungen

Slide holding devices

Verrous de tiroirs



Type 3



Type 4

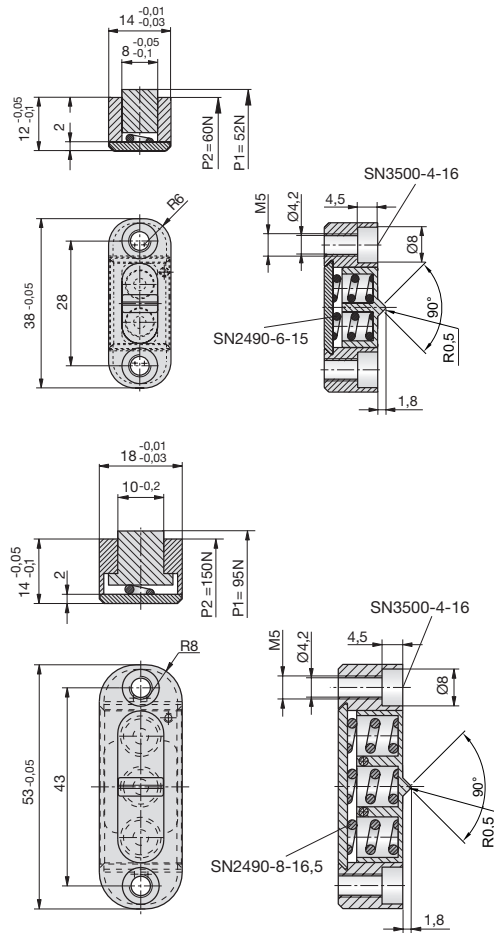

5

Z5140-

Mat.: ST/~52HRC
max. 250 °C



Z5140-Type



Type

3

4

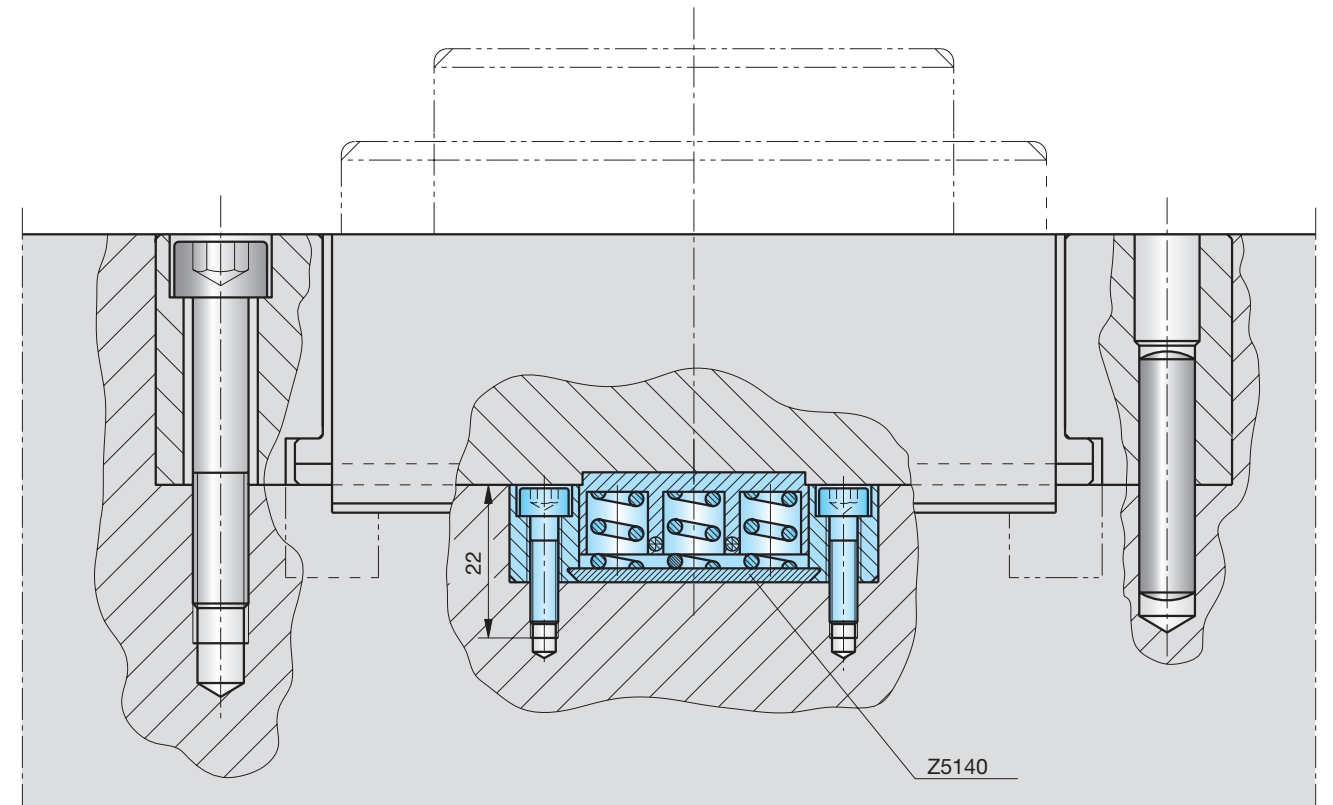
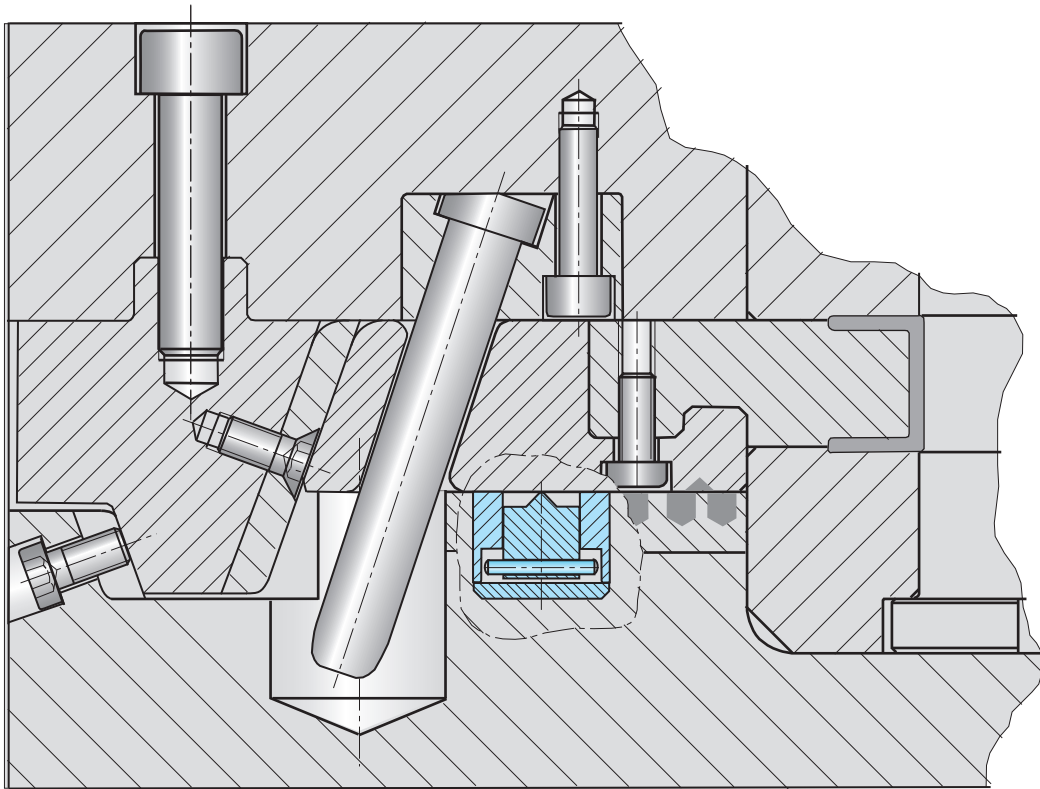

Einrastplatten

Snap-in plates

Plaquettes de retenue



Z5141-

Mat.: ST

Z5141-Type



5

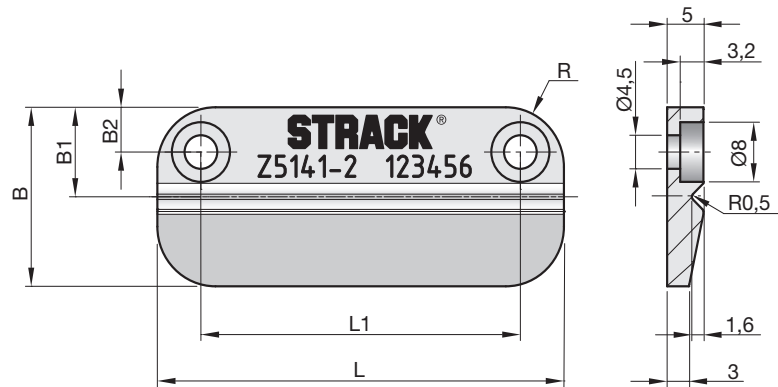

Type	B	B1	B2	L	L1	R
0	16	8	8	38	28	6
1	20	10	10	53	43	8
2	24	12	6	56	44	11

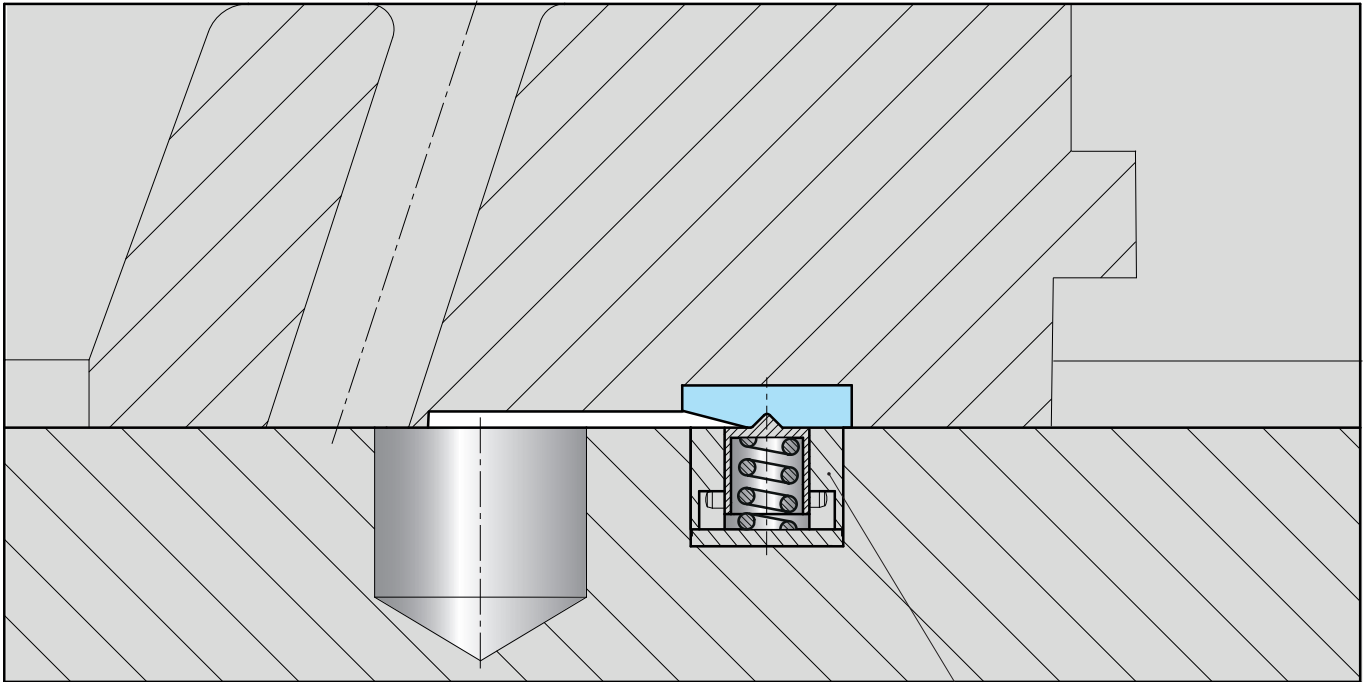

Z5140

5