

Gasdruckfedern niedrige Bauhöhe

Gas springs low total height

Ressorts à gaz hauteur totale basse

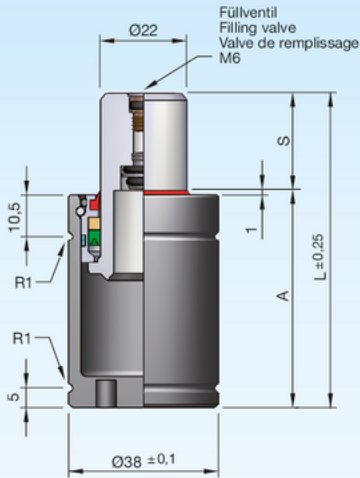

Druckmedium	Pressure medium	Médium de pression	Stickstoff (N ₂)
Max. Fülldruck	Max. filling pressure	Pression de rempl. max.	155 bar
Min. Fülldruck	Min. filling pressure	Pression de rempl. min.	35 bar
Max. Betriebstemperatur	Max. working temperature	Température de service max.	80 °C
Temperaturabhängige Druckerhöhung	Pressure increase due to temperature	Accroissement de pression sous l'influence de la temp.	0,33 %/1 °C
Instandhaltungsset	Maintenance kit	Jeu de maintenance	SN2990-K600
Max. Kolbengeschwindigkeit	Max. piston speed	Vitesse max. du piston	1,2 m/s

3

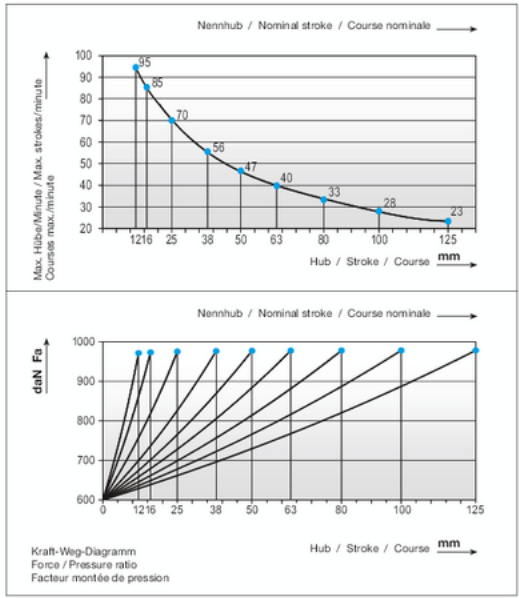

Einbauvarianten / Installation variants / Variantes de montage

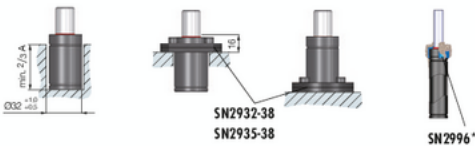

SN2809-600-



SN2809-600-S



SN2932-38



SN2935-38



SN2996*

S = Hub / Stroke / Course

bar = Fülldruck / Filling pressure / Pression de remplissage

* i SN2996 = Seite / Page 2.3.254

S	daN	daN	bar	A	L	V [l]	Fa [cm ²]	kg
12	600	955	155	49	61	0,012	3,80	0,30
16	(±5%)	955	155	53	69	0,016	3,80	0,32
25		960	155	62	87	0,025	3,80	0,35
38		960	155	75	113	0,037	3,80	0,41
50		960	155	87	137	0,049	3,80	0,45
63		960	155	100	163	0,062	3,80	0,50
80		960	155	117	197	0,079	3,80	0,57
100		960	155	137	237	0,098	3,80	0,66
125		960	155	162	287	0,123	3,80	0,79